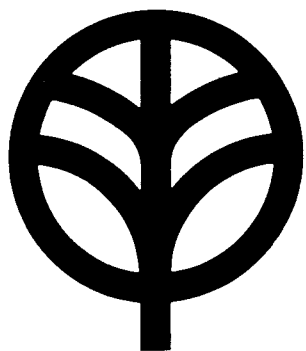


The home of the turntable

# THE VINYL ENGINE®

For more turntable manuals and setup information  
please visit [www.vinylengine.com](http://www.vinylengine.com)



**KENWOOD**  
HI/FI STEREO COMPONENTS

# SERVICE MANUAL

**KD-750**



**QUARTZ PLL DIRECT DRIVE TURNTABLE**

# CONTENTS

EXTERNAL VIEW .....	3
INTERNAL VIEW .....	4
BLOCK DIAGRAM .....	5
MOTOR CIRCUIT DESCRIPTION .....	5
LOGIC CIRCUIT DESCRIPTION .....	16
TO NEARM DESCRIPTION .....	26
HEAD SHELL .....	32
AUDIO CORD .....	34
TURNTABLE SHEET .....	34
DISASSEMBLY FOR REPAIR .....	38
ADJUSTMENT .....	40
EXPLODED VIEW .....	42
EXPLODED VIEW PARTS LIST .....	43
DESTINATIONS' PARTS LIST .....	44
PARTS LIST .....	45
PACKING .....	46
REVISED CIRCUIT .....	46
TROUBLESHOOTING .....	47
PC BOARD .....	50
SCHEMATIC DIAGRAM .....	51
SPECIFICATIONS .....	52

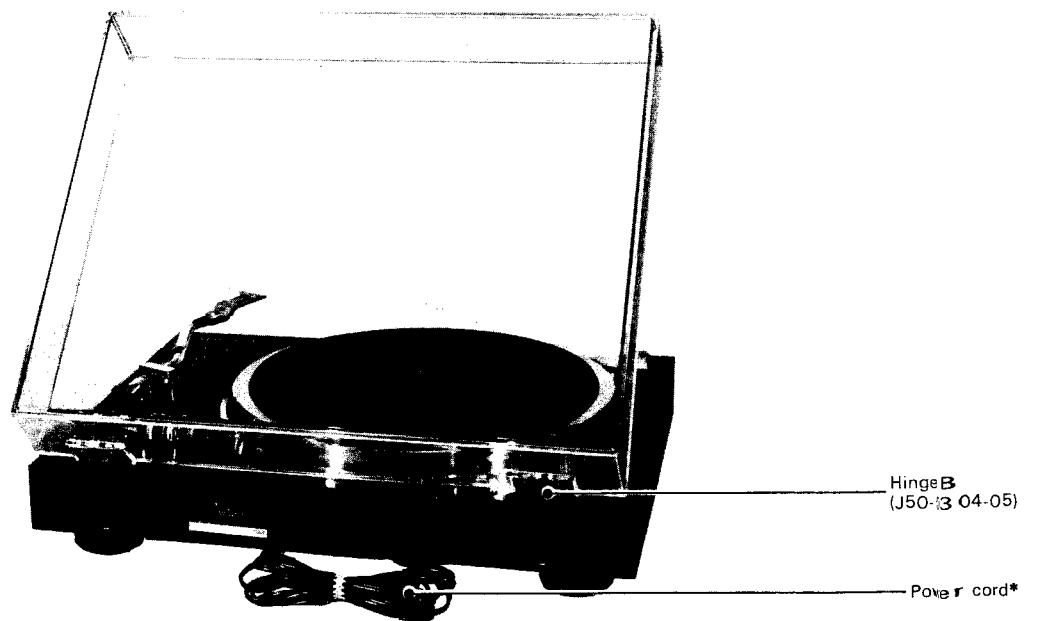
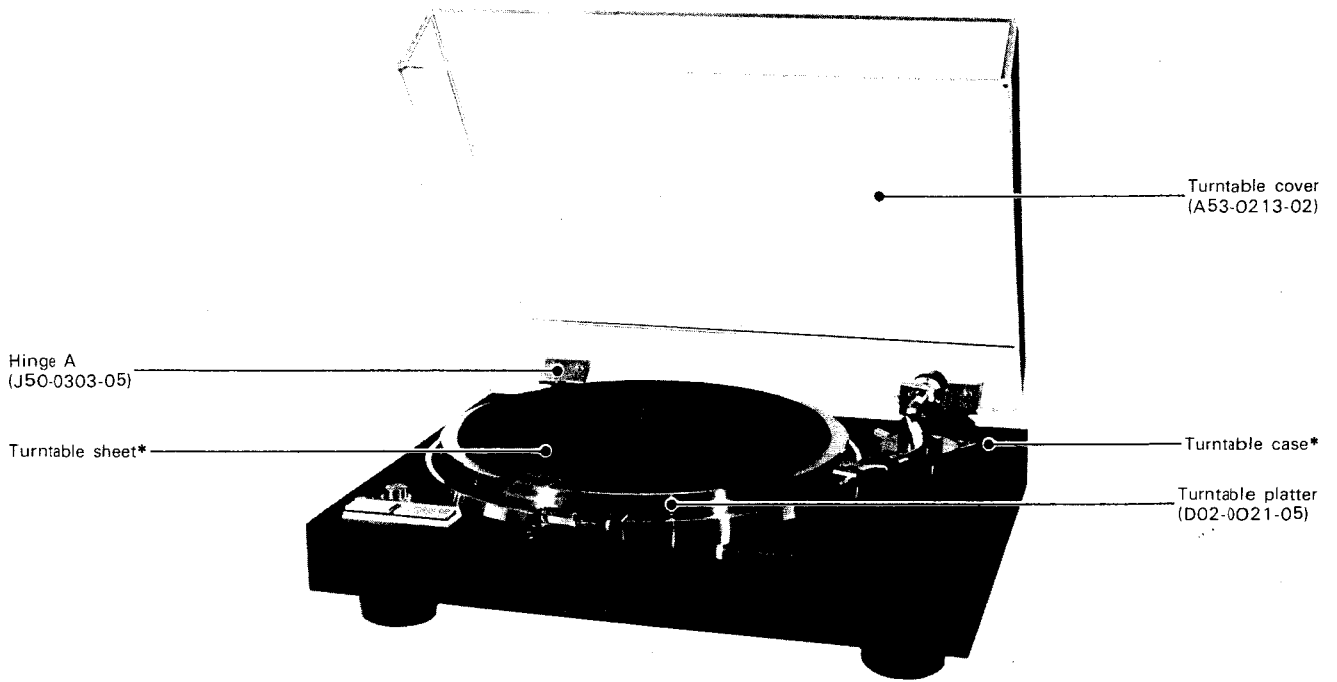
**Note:**

The products are subject to modification in components and circuits in different countries and regions. This is because each products must be used under the best condition.

This manual provides information of modification based on the standard in the U.S. for the convenience of ordering associated components and parts.

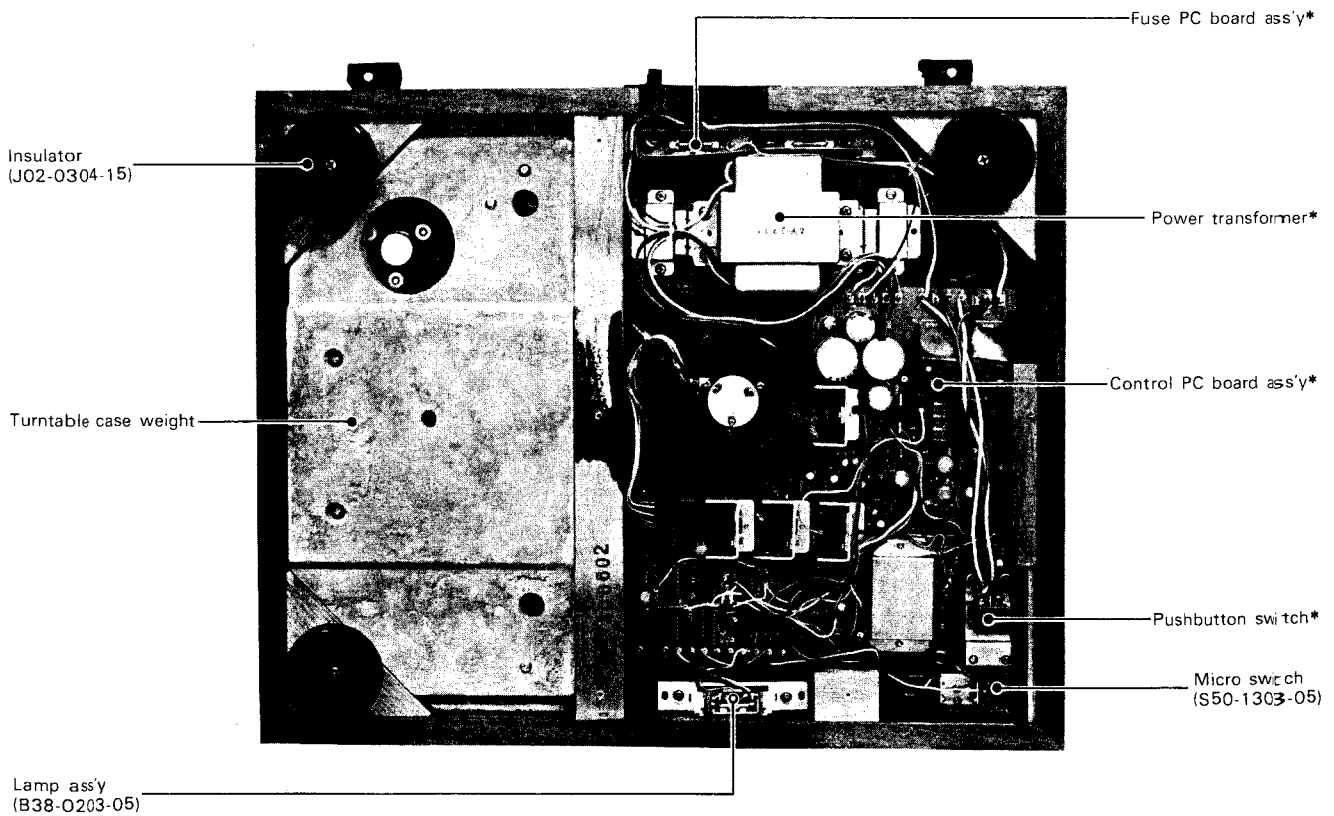
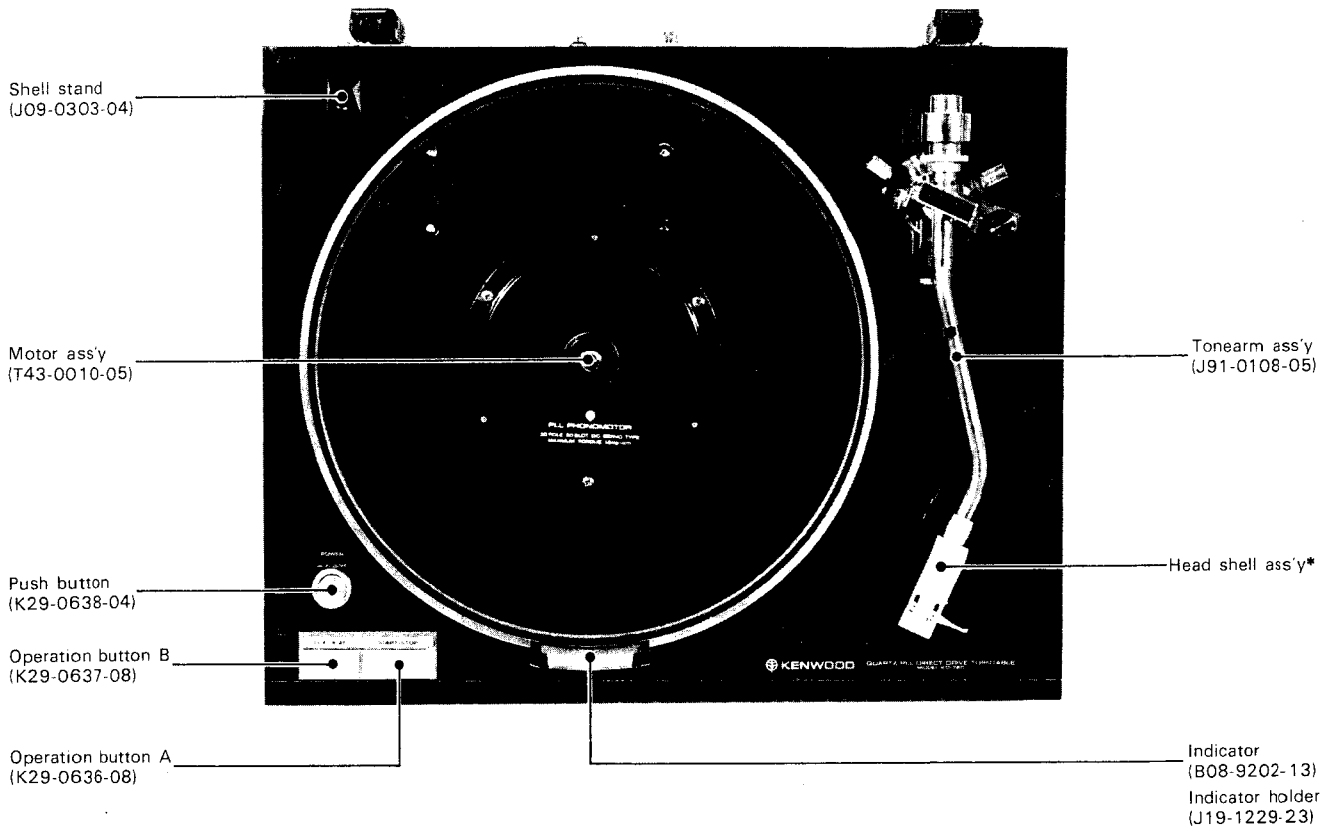
U.S.A .....	K
Canada .....	P
PX .....	U
Australia .....	X
Europe .....	W
England .....	T
Scandinavia .....	L
South Africa .....	S
Other area .....	M

**EXTERNAL VIEW**



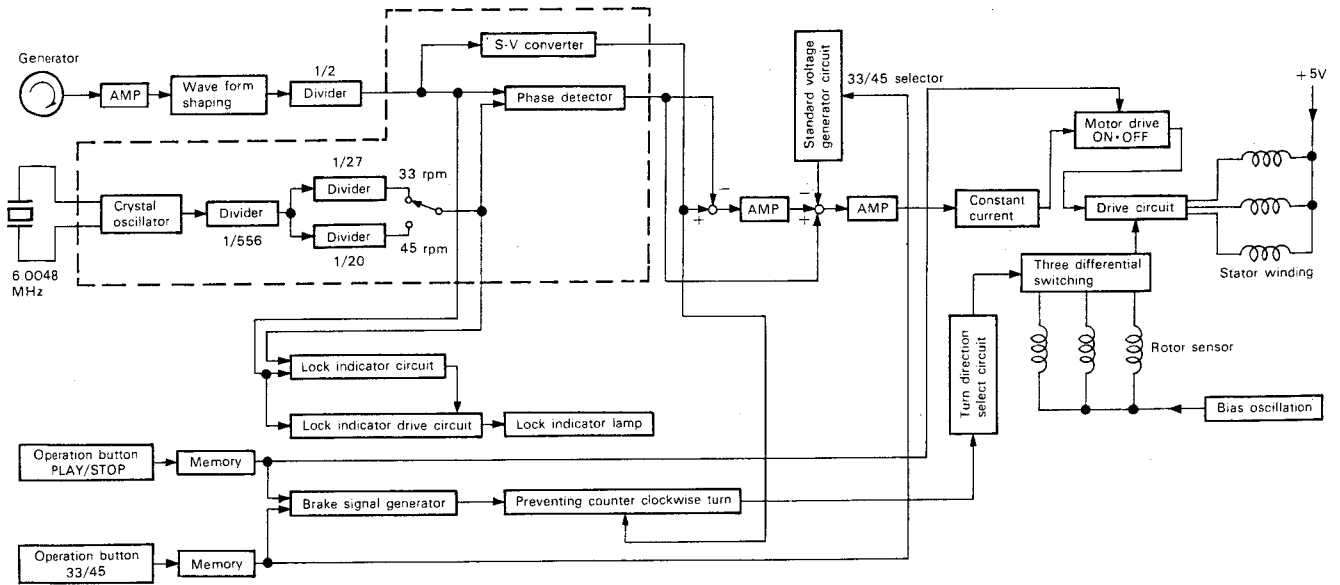
\* Refer to Destinations Parts List.

## INTERNAL VIEW



\* Refer to Destination' parts list

**BLOCK DIAGRAM/MOTOR CIRCUIT DESCRIPTION**

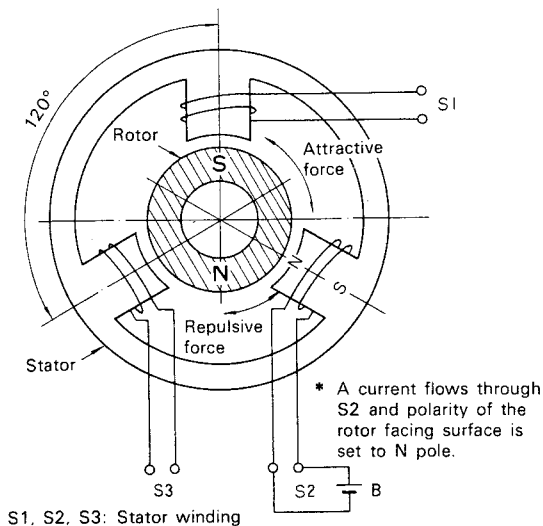


**MOTOR**

There are two types of turntable platter driving motor, AC type and DC type. Generally, an AC motor has a less efficiency than a DC motor but a DC motor needs the commutator and so causes noise and cocking. An ideal DC brushless motor with saturable magnetic core which does not have such disadvantages was developed for turntable platter direct driving motor. Details of this motor are shown in the following.

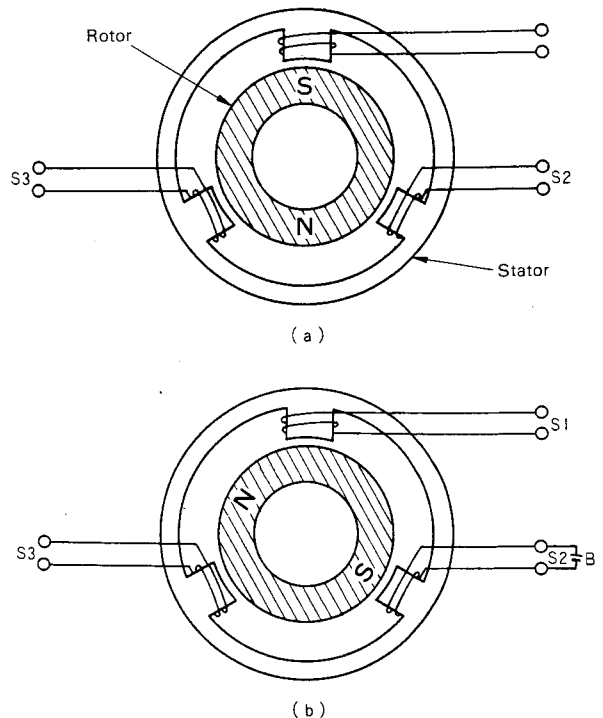
**Rotation of Motor**

An operating diagram is shown in Fig. 1-1.



**Fig. 1-1**

Assume that the S pole of rotor faces to S1, and the stator S2 is energized and its rotor facing surface is magnetized to N. Then the S pole of rotor is attracted by the N pole of S2 and the rotor rotates clockwise by 120° and stops. Similarly, when S3 is energized, the S pole of rotor is attracted by S3. Thus, by energizing stators in turn, the rotor rotates in a certain direction. (Fig. 1-2)



# MOTOR CIRCUIT DESCRIPTION

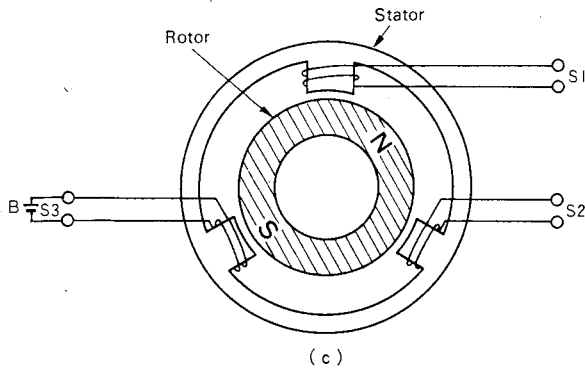


Fig. 1-2

### Clockwise Rotation

The theory of rotation of motor is explained above. Now, let the S3 be energized instead of S2 in Fig. 1-1. Then, the motor rotates counterclockwise, and this is not our desired movement. To know the rotational direction, a device detecting the position of the S pole of rotor is required. (Of course, the position can be also known by magnetizing the stator to S and detecting the N pole of rotor.)

### Position Detector

Detecting method is shown in Fig. 1-3.

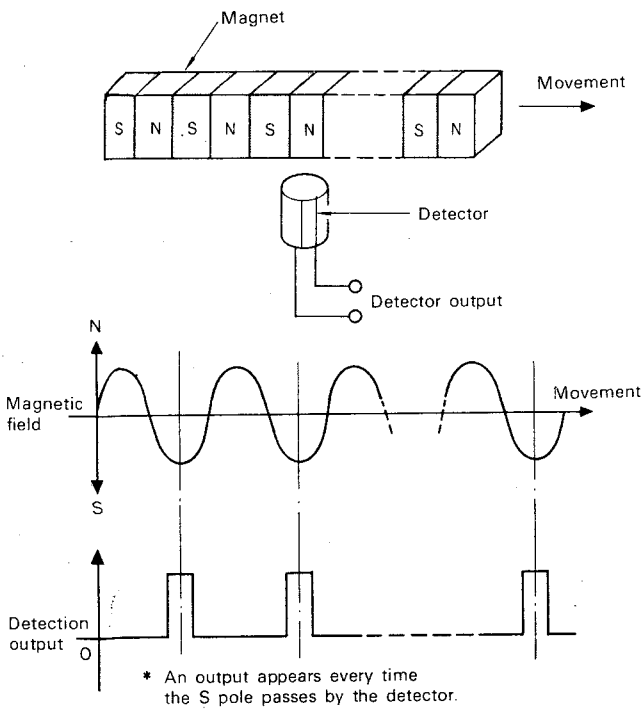
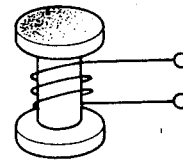


Fig. 1-3

This detecting method utilizes a property that magnetic permeability varies according to the external magnetic field. Inductance  $L$ , of an iron core coil in Fig. 1-4 is given as follows.

$$L = k \mu N^2$$



- $k$ : Constant
- $\mu$ : Magnetic permeability
- $N$ : Number of turns

Fig. 1-4

However, the detector output goes up regardless of polarity as shown in Fig. 1-5, so that this detector can not be used as it is.

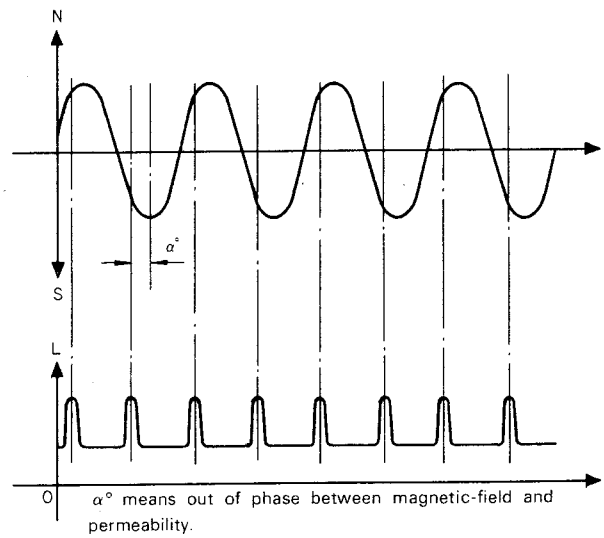


Fig. 1-5

Indeterminableness of polarity is due to change of relative magnetic permeability  $\mu_s$ , to the external magnetic field as shown in Fig. 1-6.  $\mu$  varies according to only strength of external magnetic field and regardless of polarity of external magnetic field.

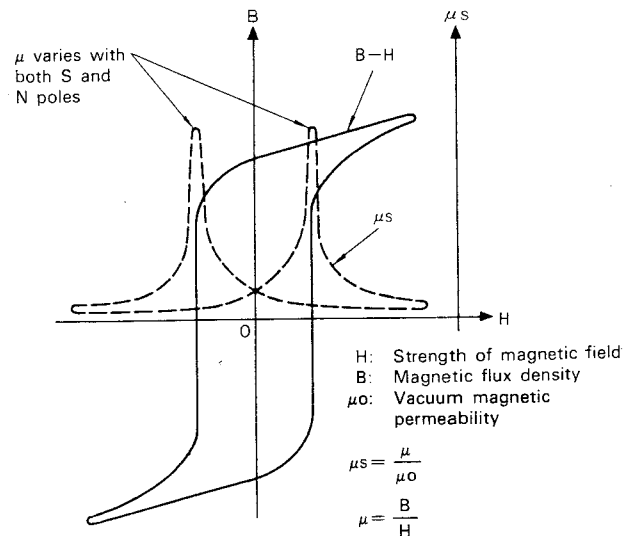
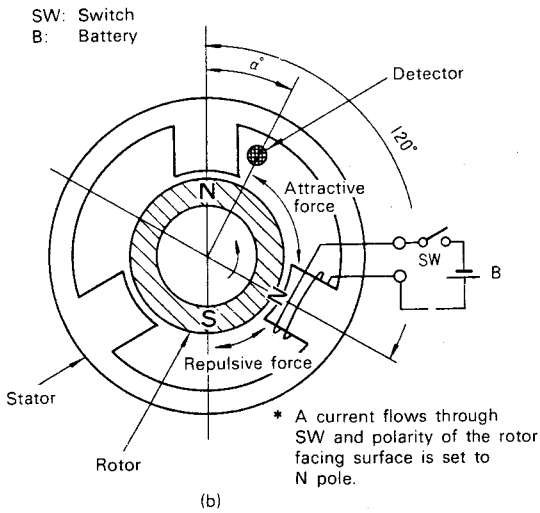
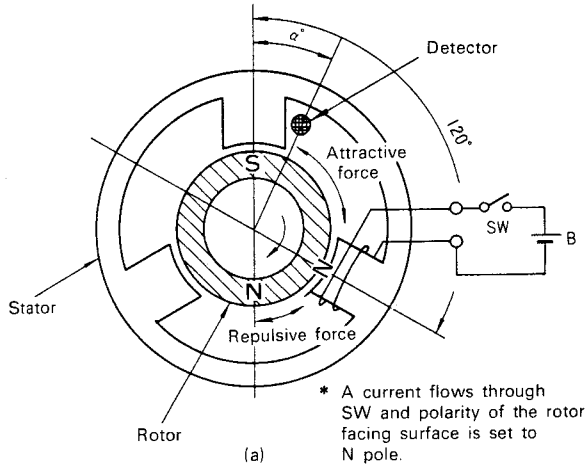


Fig. 1-6

## MOTOR CIRCUIT DESCRIPTION

### S Pole Detector

As explained in Fig. 1-3, it is necessary for the detector to detect only the S pole of rotor. If a detector shown above is used, the rotor may rotate in the undesirable direction.

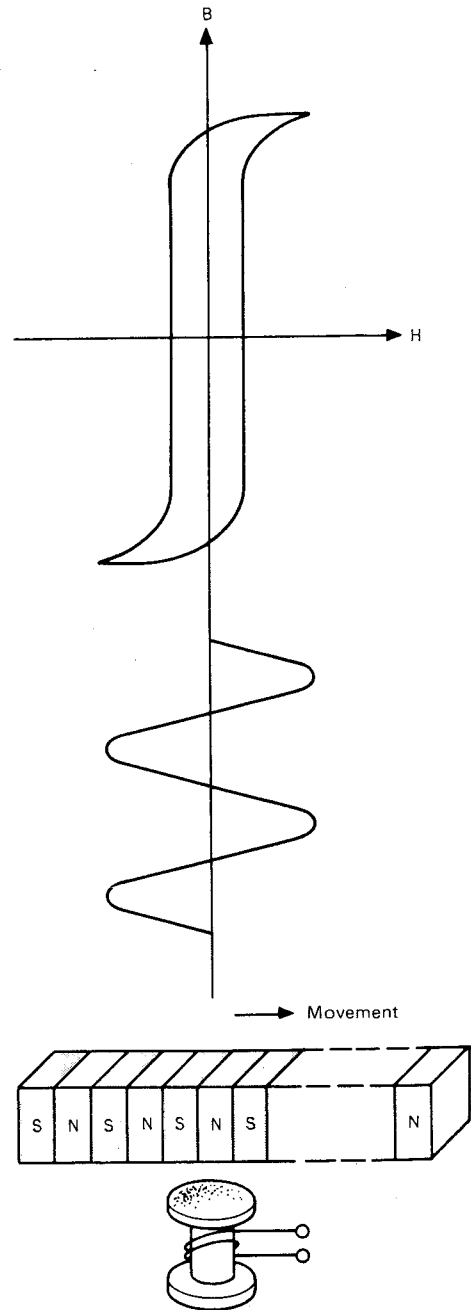


**Fig. 1-7**

When SW is closed, the polarity of the rotor facing surface is set to N. This detector responds to N and S equally, so the same outputs are obtained in the both case of (a) and (b). However, when SW is turned on by means of an appropriate circuit through which these detector outputs are processed, the rotor rotates clockwise by 120° in case of (a) and counterclockwise by 60° in case of (b).

Note:  $\alpha^\circ$  is taken so that the above states (where S or N is just facing the stator on the top) can be properly detected, because  $\mu$  is not in the maximum when magnetic field is in the maximum and so it is necessary to compensate the phase shift mechanically.

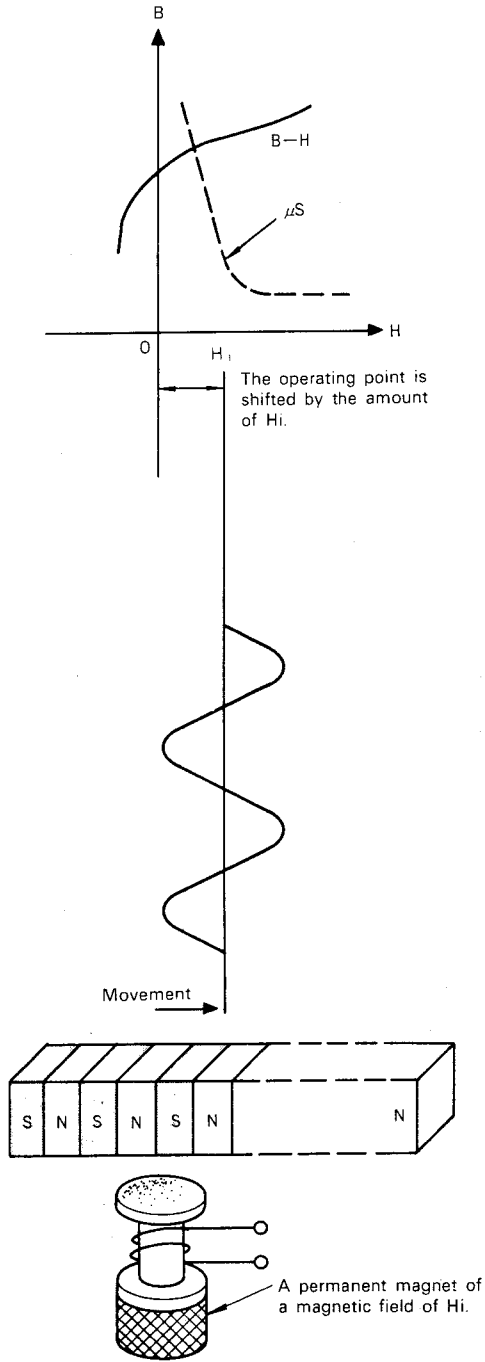
Then, a permanent magnet for bias is attached to the detector to increase the output level for the S pole of rotor and decrease that for the N. Thus,  $\mu$  is in the maximum at every peak of magnetic field of the rotor S pole, otherwise  $\mu$  maintains a constant value which is smaller than the peak value.



(a: Not employ magnet for bias.)

**Fig. 1-8A**

**MOTOR CIRCUIT DESCRIPTION**

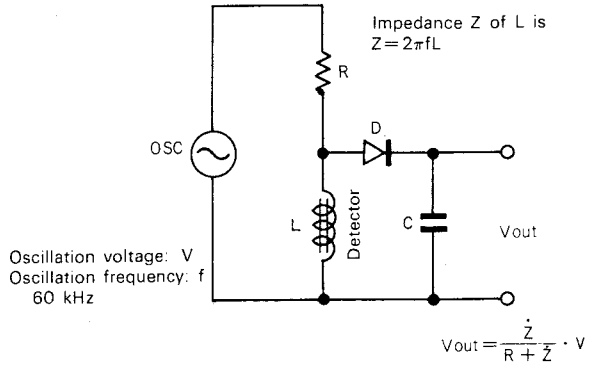


(b: In the case of attaching magnet for bias.)

**Fig. 1-8B**

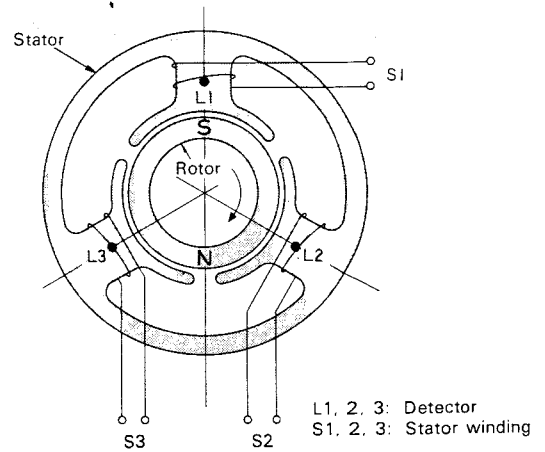
**To Convert  $\mu$  into Voltage to Obtain Continuous Rotating Signal**

To obtain continuous rotating force, the stator winding to be energized must be changed in turn. The voltage converted from  $\mu$  detected is used to battery for a stator winding. Since the coil impedance varies according to  $\mu$ , voltage at  $V_{out}$  is in proportion to  $\mu$ .

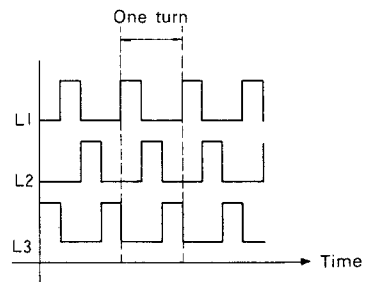


**Fig. 1-9**

When the rotor rotates in a state of Fig. 1-10 each output of detectors is as shown in Fig. 1-11. Continuous rotation is achieved by connecting these detectors and stator windings as shown in Fig. 1-12.



**Fig. 1-10**



**Fig. 1-11**

## MOTOR CIRCUIT DESCRIPTION

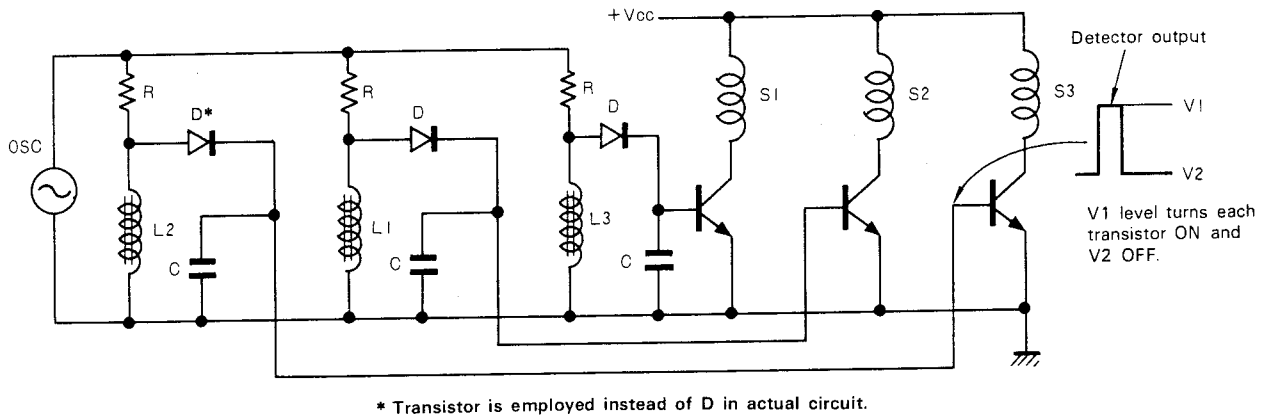


Fig. 1-12

### To Obtain Switching Signal

A circuit to obtain switching signal is shown in Fig. 1-13.

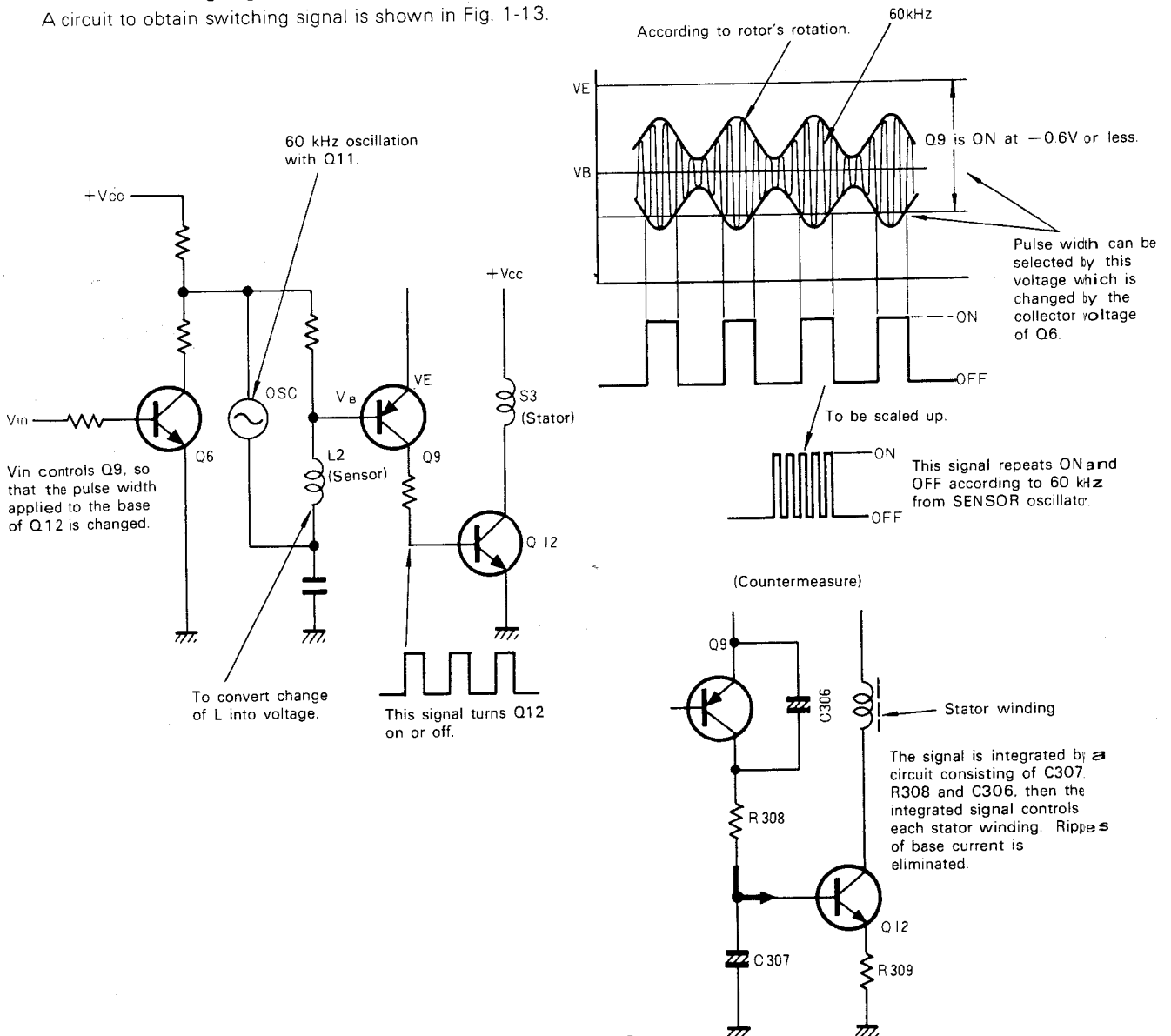


Fig. 1-13

## MOTOR CIRCUIT DESCRIPTION

### Motor Operation of KD-750

The fundamental operation of DC motor is explained in the previous sections. However, such a motor causes cockings three times for a rotation and the moment of inertia of the turntable platter is not enough to eliminate these cockings. When a turntable platter direct driving motor of 33-1/3 is used, cocking frequency is 1.66 Hz. If the number of stator windings is increased to 6, the number of rotor poles is increased to 4 and detectors are placed at 60° intervals, and S1 and S4, S2 and S5, and S3 and S6 are connected in parallel, then the cocking frequency is changed to 3.33 Hz. Similarly, when a 30-winding, 20-pole motor is used, the cocking frequency is 16.66 Hz and so apparent cocking disappears.

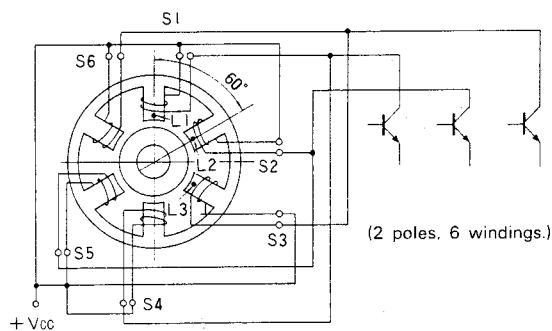


Fig. 1-14

### Braking Effect

The rotating direction is selectable as described in the fundamental theory of motor, however, a large torque is required to rotate a heavy turntable platter. To increase rotating force, the detecting angle was determined to 120°. To detect clockwise rotation and S poles, the output voltage of rotor sensor was designed to be variable. The output is also obtained from the resistor side but results in only a rotating force of 60°, so that this force is used for braking.

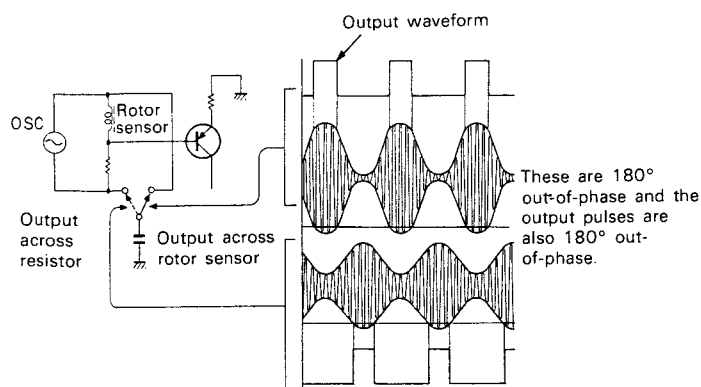


Fig. 1-15

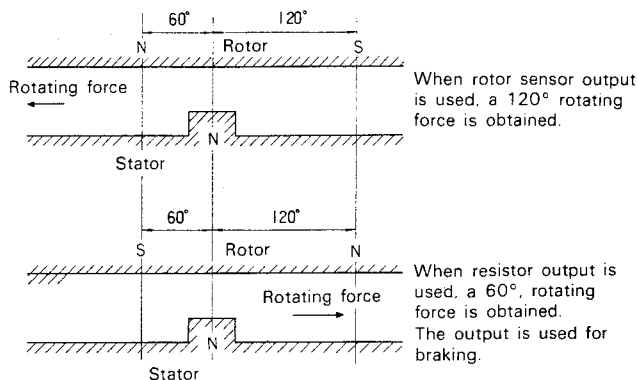
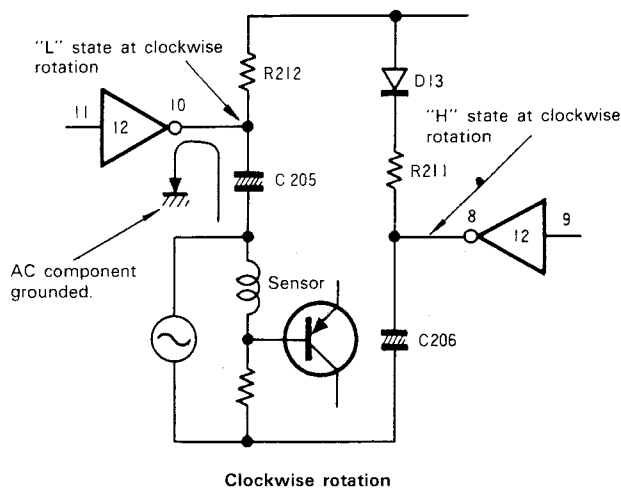
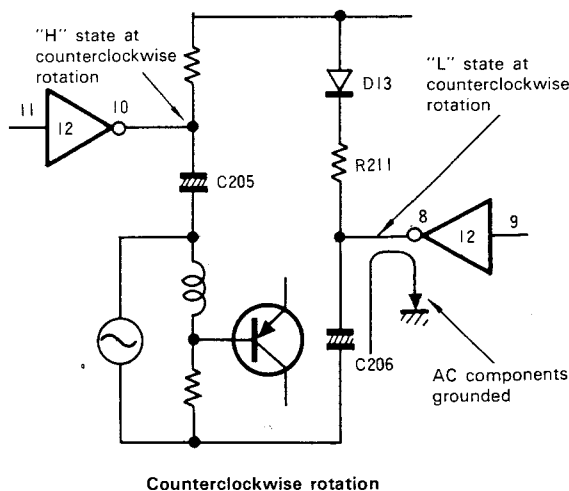


Fig. 1-16

In the actual circuit, when pin 10 of IC12 is set to "L", one side of sensor is AC-grounded so that the rotor sensor output is used. Otherwise, pin 8 of IC12 is set to "L", the resistor output is used.



Clockwise rotation



Counterclockwise rotation

Fig. 1-17

## MOTOR CIRCUIT DESCRIPTION

### What Is the "Quartz-Locked Phase Control" System?

Conventional control system for rotating platters is called the "Turning Speed Control" system, in which only turning speed information is fed back to the control circuit. In the Quartz Phase Locked Loop Control System, phase component of rotation is also fed back to the control circuit in addition to the turning speed information. This new control system reduces ultra-low variation frequency of rotation such as drift.

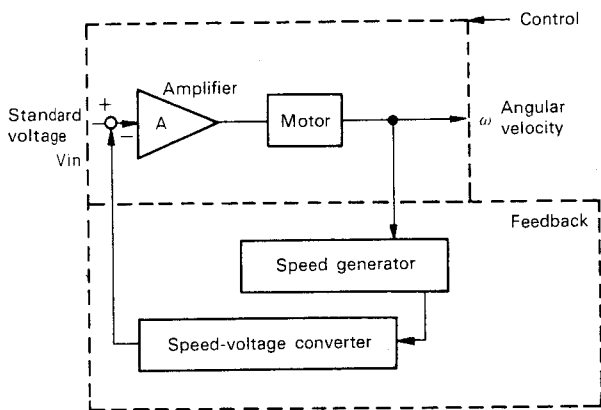


Fig. 1-18a

Figure 1-18 (b) is a block diagram of the turning-speed controller. Closed loop gain G1 of the circuit shown in Fig. 1-18 (b) is described as

$$G1 = \frac{M}{1 + M\alpha}$$

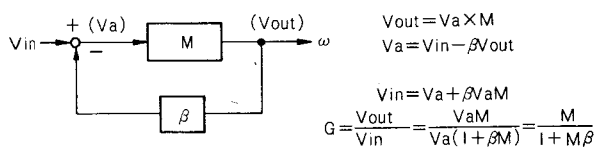


Fig. 1-18b

where M is an object to be controlled, and β is a feedback constant as illustrated in the figure.

When an amplifier (Gain "A") is added to the circuit (see Fig. 1-18 (a)), the closed-loop gain G2 is expressed as

$$G2 = \frac{AM}{1 + AM\beta}$$

Assuming that amplifier gain A is infinite, G2 is then

$$G2 = \frac{1}{\frac{1}{AM} + \frac{AM\beta}{AM}} = \frac{1}{\beta}$$

As known from this equation,  $V_{in} \times 1/\beta$  appears on the output whatever the variation of M may be.

The KD-750 uses in it an innovative servo system called the S-V Servo System utilizing the quartz-lock technology. This feature greatly improves closed-loop servo system's input-output linearity.



Fig. 1-18c

Generally, a servo system linearity depends on β vs angular velocity characteristic. The  $V_{in} - \beta$  curve would be a  $1/x$  curve unless using β which is reciprocal to turning speed. Since the turning speed is proportional to the speed-generator frequency, the conventional turntables using frequency-voltage converters are liable to suffer from poor closed-loop linearity. The S-V servo, on the contrast, exhibits an excellent closed-loop linearity because of its period-voltage converter.

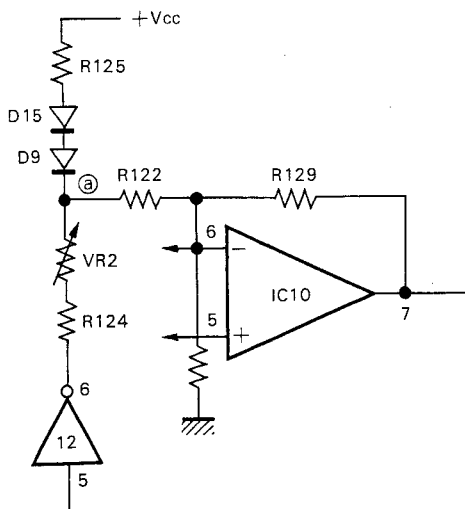
## MOTOR CIRCUIT DESCRIPTION

### Speed Control (See P13)

A signal of a frequency in proportion to rotation of the motor is generated by the detector. This voltage is around 20 mV which is too small for phase comparison. Therefore, the voltage is amplified with IC1 ( $\mu\text{PC1023H}$ ) and then applied to Q1. Q1 generates the clock pulse and IC2 regulates the clock pulse. The clock pulse is applied to both IC9 and the lock indicator driver IC. IC9 generates a signal compared with the phase lock voltage. After checking the correct voltage whose phase has been compared and checking the turntable platter for rotation, the indicator is lit on by the lock indicator driver.

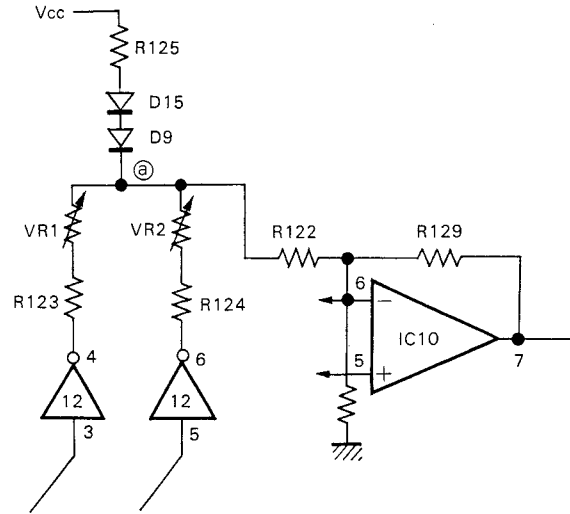
An output signal of FG input to pin 4 of IC9 is applied to the S-V (speed-voltage) sample hold circuit through a couple of inverters as well as applied to the phase comparator. A S-V converted voltage is output from pin 7 of IC9 and a phase compared signal between FG and the standard oscillator is output from pin 11 of IC9. The S-V converted voltage and the phase compared voltage are applied to IC10 and then difference between them and the standard voltage are applied to pin 6 of IC10 to be compared with the S-V converted voltage again. The compared output is then applied to pin 12 of IC10 to control the base bias of Q6, so that the pulse width which determines rotational force of motor can be controlled. (Refer to the motor section.)

The speed standard voltage is generated with IC5. At 33-1/3 rpm, pin 8 of IC5 is "H" and pin 9 is "L". At 45 rpm, pin 8 of IC5 is "L" and pin 9 is "H".



45 rpm

Fig. 1-19



33-1/3 rpm

Fig. 1-20

At each speed, voltage at  $\textcircled{a}$  is the speed standard voltage, which is applied to pin 6 of IC10. Difference between the standard voltage and the phase and speed difference is output from pin 7 of IC10.

### Quartz Lock IC, SM6415A

SM6415A consists of a standard oscillator, a 1/4 counter, a 10 bit programmable counter, a 1/20 or 1/27 counter, a 1/2 counter, a timing generator, a sample hold, period-voltage converter and a sample hold phase comparator as shown in Fig. 1-21. Program inputs of P0 ~ P7 and externally programmable and P8 and P9 have been internally programmed.

Product Number	Internal programming input		Maximum program number
	P8	P9	
AM6415A-1	0	0	1~255
SM6415A-1	1	0	256~511
SM6415A-3	0	1	512~767
SM6415A-4	1	1	768~1023



## MOTOR CIRCUIT DESCRIPTION

Relation among the phase comparator input  $f_c$ , the strobo  $f_{ST}$  and the standard X'tal frequency  $f_{Q1N}$  is given as follows.

$$f_c = f_{ST} = f_{Q1N} \times \frac{1}{4} \times \frac{1}{N} \times \left( \frac{1}{20} \text{ or } \frac{1}{27} \right) \times \frac{1}{2}$$

N: Dividing Number of Program Counter, which is determined by program input. (1/566 for KD-750)

The phase comparator and the period-voltage converter use the sample hold circuit. Timing relation between the sample pulse and the reset pulse is shown in Fig. 1-22.

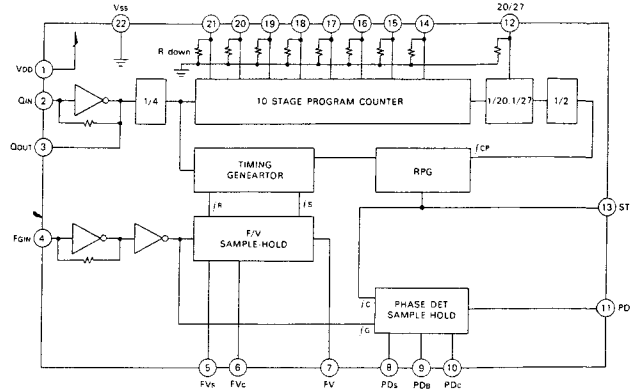
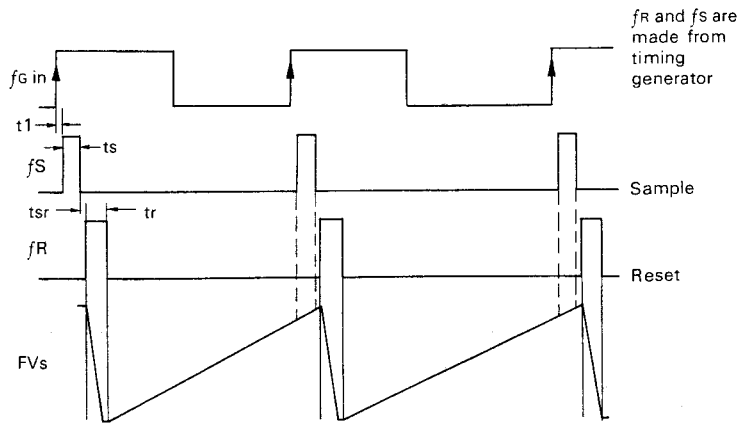
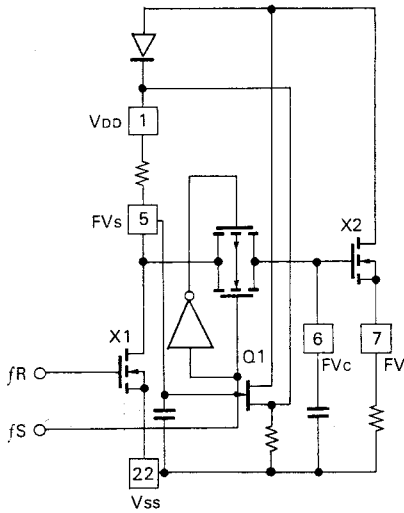
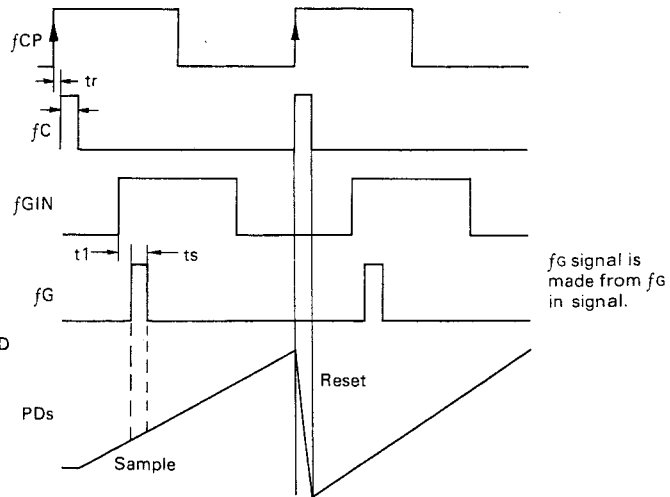
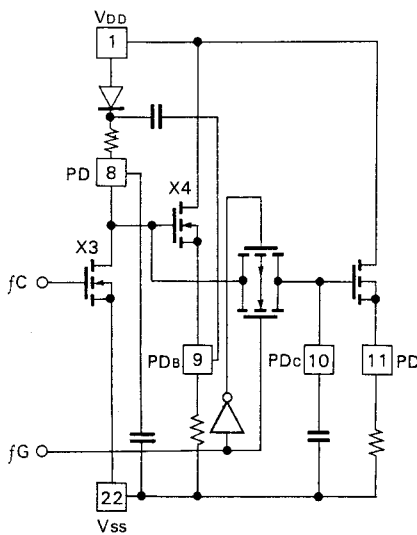


Fig. 1-21



Frequency/voltage converter

Fig. 1-22



Sample-hold phase det.

Fig. 1-23

### MOTOR CIRCUIT DESCRIPTION

#### Sample Hold Operation

A voltage generated by the FG coil is shaped and applied to IC9. IC9 performs phase comparison, phase-voltage conversion, and frequency-voltage conversion. For these conversions, the sample hold circuit is used.

The basic sample hold circuit is shown in Fig. 1-24.

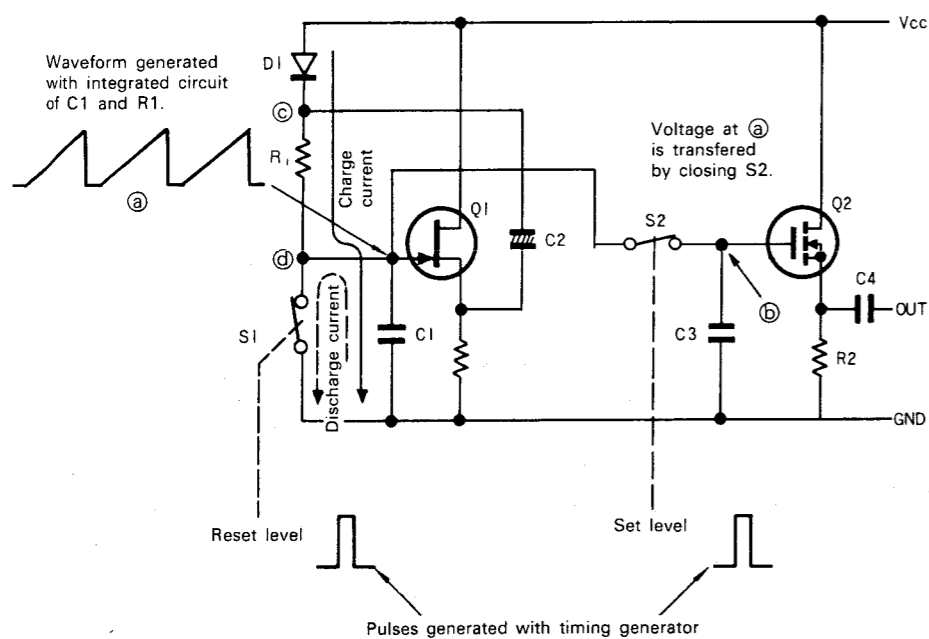
#### Operation

Let S1 be OPEN and S2 be switched OFF→ON. C1 has been charged since S1 is OPEN. Now, if S2 is turned OFF→ON→OFF and  $C1 > C3$ , C3 is charged with the voltage

at point (a). That is, since C3 is small, the voltage at (a) is held across C3 as it is. Then, when S1 is closed, C1 is discharged through S1 and the circuit is in reset state.

Charged voltage of C3 biases the gate of Q2 immediately after S2 is turned off and the output is according to the voltage of the hold time.

For S-V conversion, a lamp wave and set and reset pulses are made from the square wave of FG. For phase comparison, these signals are made from the standard signal of X'tal oscillator and the square wave of FG.



The gate voltage of Q1 is equal to the source voltage because Q1 operates in source follower. Voltage  $V_c$  at (c) is given as  $V_c = V_{cc} + d$  and voltage  $V_d$  across R1 is given as  $V_d = (V_{cc} + d) - d$ . Thus, current through R1 is constant because voltage across R1 is always constant.

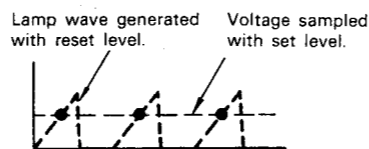
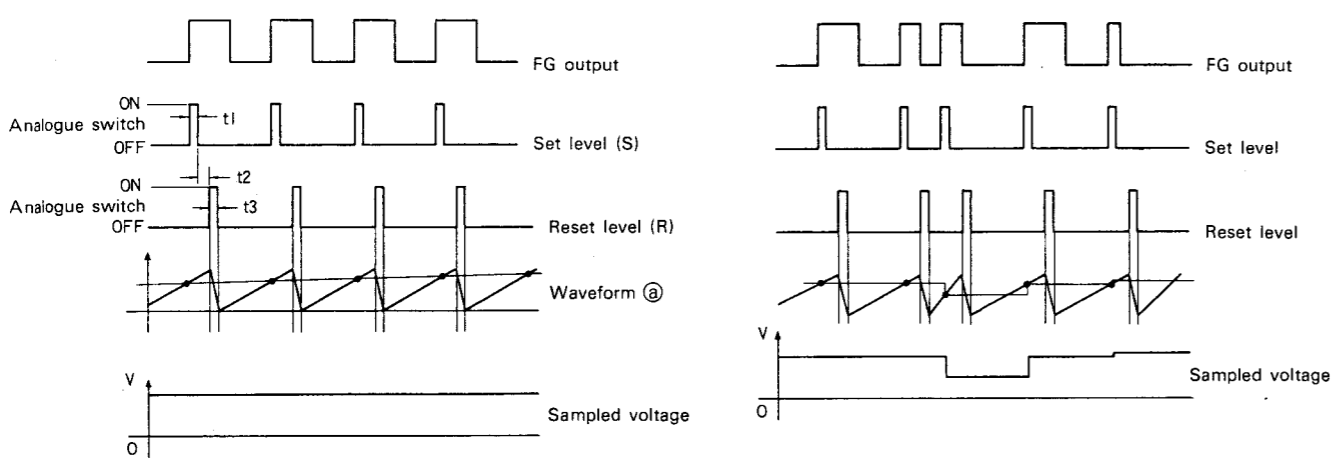


Fig. 1-24



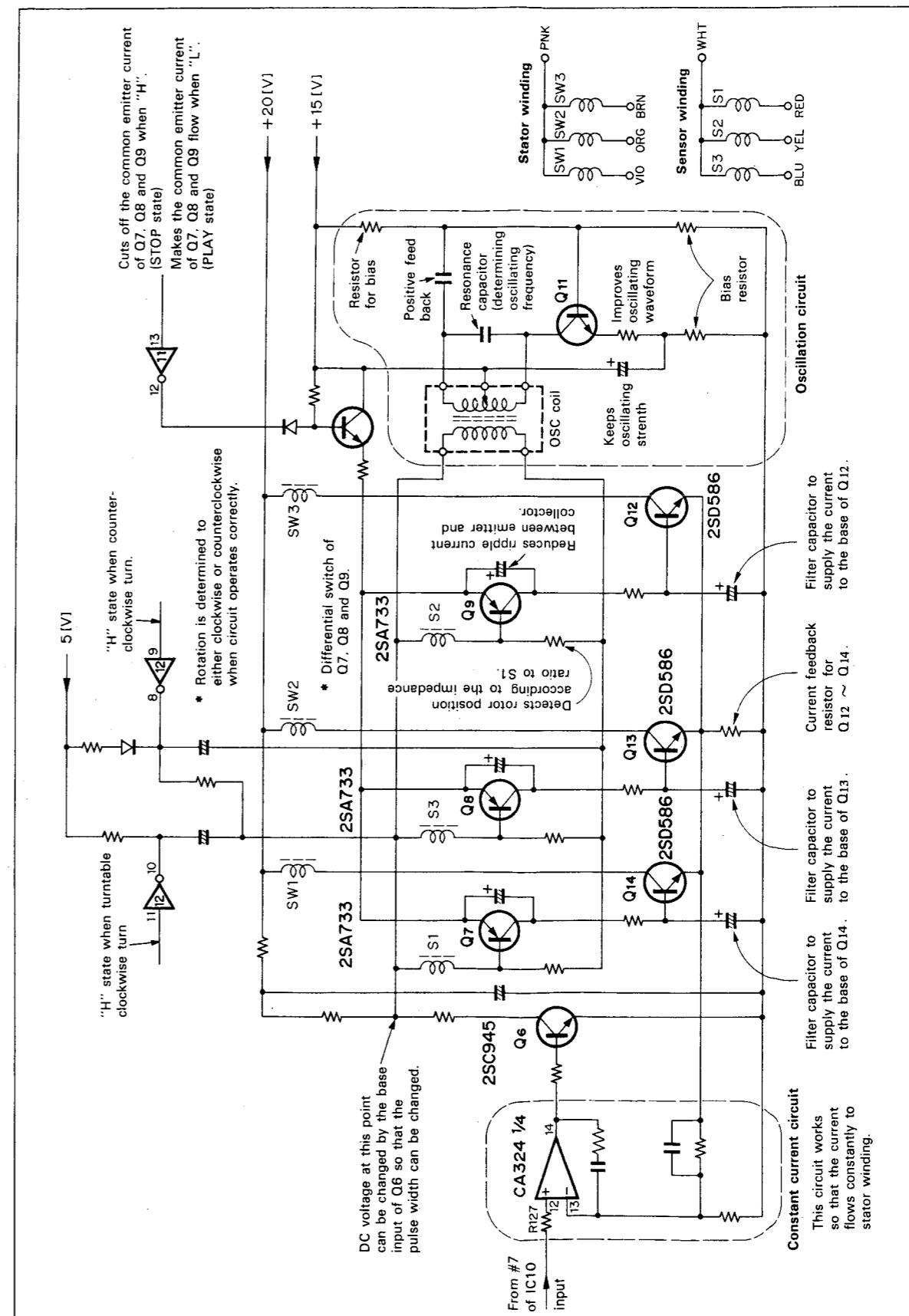
When FG output is constant

Fig. 1-25

When FG output is irregular

Fig. 1-26

### MOTOR CIRCUIT DESCRIPTION



Constant current circuit  
This circuit works so that the current flows constantly to stator winding.



## LOGIC CIRCUIT DESCRIPTION

### OR Gate

The output Y is "H" state when at least one input of A and B is "H". An example and the truth table of OR are shown in Fig. 2-6. Explanation of operation is omitted.

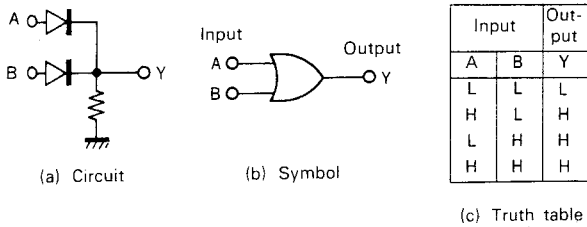


Fig. 2-6

### NOT Gate (Inverter)

When the input A is "H" state, the output Y is "L" state. Otherwise, when A is "L", Y is "H". Such an inverter as the output is the opposite of input is defined as NOT gate. An example and the truth table are shown in Fig. 2-7.

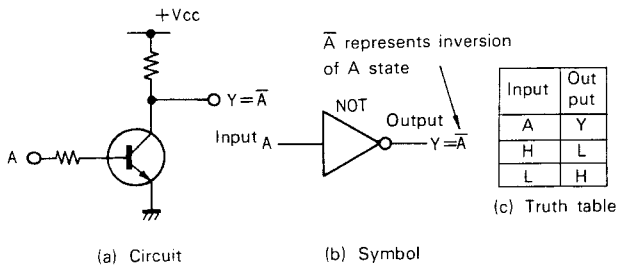


Fig. 2-7

### NAND Gate

NAND gate is defined as a circuit which outputs "L" state when all the inputs are "L" state. The logic symbol and the truth table is shown in Fig. 2-8.

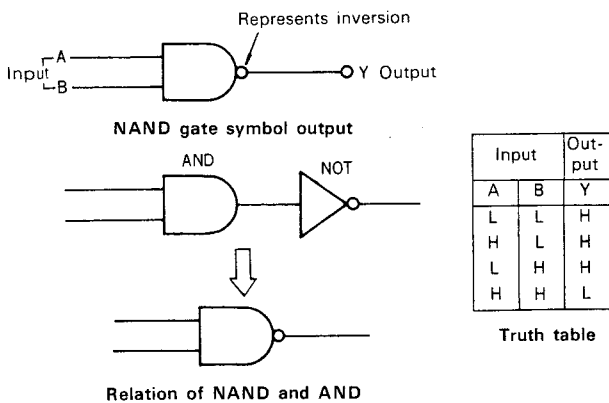


Fig. 2-8

### NOR Gate

NOR gate is defined as a circuit which outputs "L" state when at least one input is "H" state. The logic symbol and the truth table are shown in Fig. 2-9.

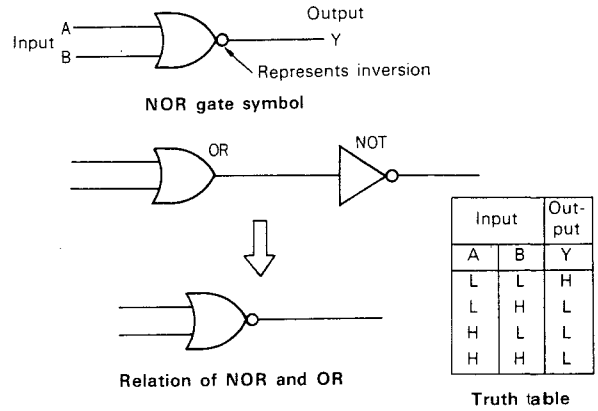


Fig. 2-9

### Positive Logic and Negative Logic

The "H" and "L" levels described above are relative levels, that is, a relative high level is "H" and relative low level is "L". Such two logical states as ON and OFF (logical 1 and logical 0) are also expressed by "H" and "L". The positive logic defines "H" level as "1" and "L" level as "0". Oppositely, the negative logic defines "H" level as "0" and "L" level as "1".

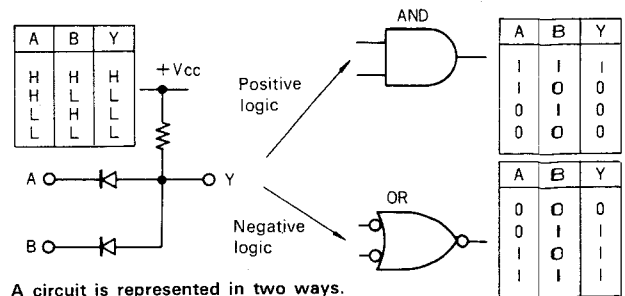


Fig. 2-10

### Flip-Flop

Formerly, a mechanically locked button or a relay circuit was used to keep operational functions. The KD-750 uses logic circuits for all operations, so that single touch is required to start/stop operation or select revolution number, 33-1/3 or 45 rpm. Because, the flip-flop (FF) maintains the selected state. In the following sections, types of FF and their operations are explained.

## LOGIC CIRCUIT DESCRIPTION

### What Is Flip-Flop?

FF has two stable states of "H" state and "L" state. If an input which sets "H" (or "L") state is applied, FF is set to "H" (or "L") state and maintains the state until an input which sets "L" (or "H") state is applied.

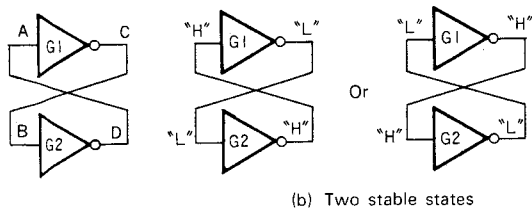
### Types of FF

There are three types of multivibrator: the astable multivibrator has no stable state and oscillates; the monostable multivibrator has a stable state and, when triggered, is set to the unstable state but returns to the stable state after a certain time; the bistable multivibrator has two stable states and, when triggered, changes the state in turn. The last one is called flip-flop because of operation.

- (1) BIASTABLE MULTIVIBRATOR or FLIP FLOP
- (2) MONOSTABLE MULTIVIBRATOR or ONE SHOT MULTIVIBRATOR
- (3) ASTABLE MULTIVIBRATOR

Type of multivibrator

FF can be configured with inverters as shown in Fig. 2-11.



Fundamental diagram of FF consisting of 2 inverters

Fig. 2-11

The inputs A and B of inverters G1 and G2 are connected to the output D and C, respectively.

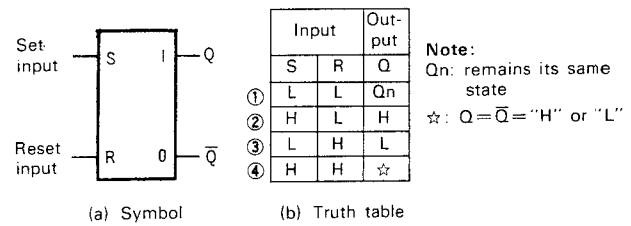
If A is "H", C will be "L" state. Since C is connected to B, B will be "L" state, so that D will be "H" state. Since D is connected to A, the input of G1 will be the assumed level, "H" state. Otherwise, if A is "L" state, D will be "L" state, so that the input of G1 will be the assumed level.

This circuit has two stable states and can be called FF. However, it can not be controlled from the outside. A FF to which control inputs, R and S are added is called RS-FF.

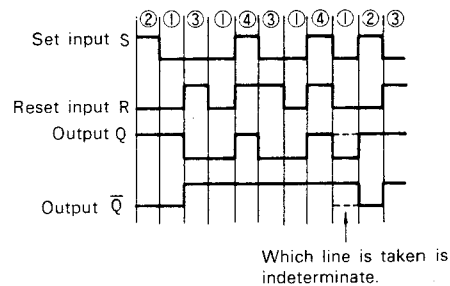
### RS-FF

Definition of RS-FF is as follows: consider both S and R input to be "L" state, when the S input goes to "H" state, the Q output will be "H" state. Then when the R input goes to "H" state, the output will be "L" state.

When the output Q is "H" (or "L") the output  $\bar{Q}$  must be "L" state (or "H"). Namely the FF has two output signals one of which is the complement of other. If, however, the both inputs R and S goes to "H", the both outputs Q and  $\bar{Q}$  will be set to either "H" or "L" states. (Which state is selected depends on type of gate to be used.) Therefore, when RS-FF is used, the set and reset inputs must not be set to "H" at a same time.



Definition of RS-FF



Timing chart of RS-FF

Fig. 2-12

Let FF be formed by Cross-Coupling NOR gates. Each output is connected to an input of the other NOR gate.

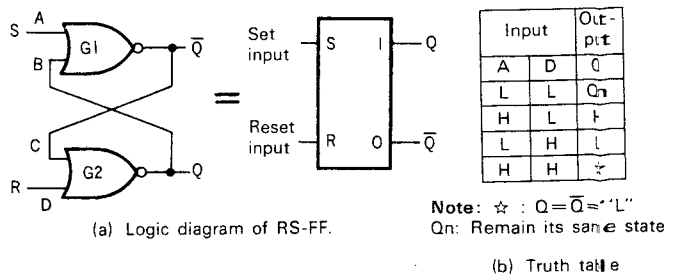


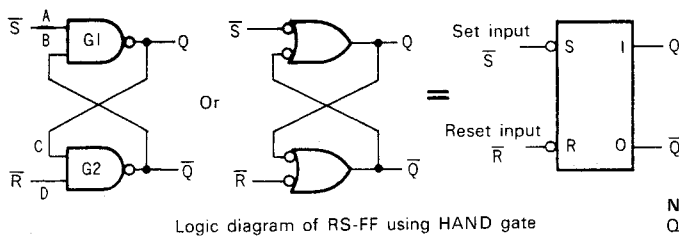
Fig. 2-13

## LOGIC CIRCUIT DESCRIPTION

Operation is explained in the following.

- 1) It is assumed that the inputs A and D have "H". Since NOR gate outputs "L" when at least one input goes to "H", both output Q and  $\bar{Q}$  are "L". (This does not meet the theory.)
- 2) Input A: "H", input D: "L"  
Output  $\bar{Q}$  is "L" since input A is "H". Since output  $\bar{Q}$  is connected to input C, input C is "L". Since input D is also "L", output Q is "H".
- 3) Input A: "L", input D: "H"  
Output Q is "L" since input B is "H". Since output Q is connected to input B, input B is "L". Since input A is also "L", output  $\bar{Q}$  is "H".
- 4) Input A: "L", input D: "L"  
Output Q is determined by input B since input A is "L". Output  $\bar{Q}$  is determined by input C since input D is "L". If output Q is "H", output  $\bar{Q}$  will be "L". If output Q is "L", output  $\bar{Q}$  will be "H". The FF will remain in its same state, i.e. will not change states.

The inputs are indicated by A~D in the above explanation. A and D correspond to R and S in the truth table of RS-FF, respectively. Thus, a RS-FF can be made by two NOR gates.



Logic diagram of RS-FF using NAND gate

Fig. 2-14

Next, let a RS-FF be made by NAND gates. Operation is explained in the following.

A RS-FF has two inputs of R (Reset) and S (Set). As shown in the truth table, when both inputs  $\bar{R}$  and  $\bar{S}$  goes to "H", Q and  $\bar{Q}$  will remain in its same state. ( $\bar{S}$  means that the output Q will be "L" when the  $\bar{S}$  input goes to "H".  $\bar{R}$  means that  $\bar{Q}$  will be "L" when the  $\bar{R}$  input goes to "H".) That is, when the both inputs are kept "H", the FF will remain in its present state. (For NOR, all the outputs are inverted.)

When the S input goes to "L", output Q will be "H" and output  $\bar{Q}$  will be "L". That is, you can set output Q to "H" by setting the  $\bar{S}$  input to "L" if necessary. Therefore,  $\bar{S}$  is called Set-Input gate.

You can reset the state set with the  $\bar{S}$  input to the original state by setting the  $\bar{R}$  input to "L". Therefore, the  $\bar{R}$  input is called Reset-Input gate.

Q and  $\bar{Q}$  must be complementary to each other. However, when both inputs  $\bar{S}$  and  $\bar{R}$  are "L", outputs Q and  $\bar{Q}$  are both "H".  $\bar{S}$  and  $\bar{R}$  must not be set to "L" at a same time.

Figure 2-15 shows a RS-FF including control gates (inverters in this case). The RS-FF part may be particularly called latch.

Input	Output	
$\bar{S}$	$\bar{R}$	Q
L	L	☆
H	L	L
L	H	H
H	H	Qn

Note: ☆ : Q =  $\bar{Q}$  = "H"  
Qn: Remains its same state

(b) Truth table

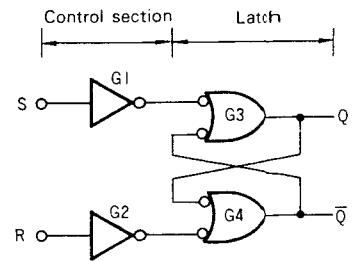
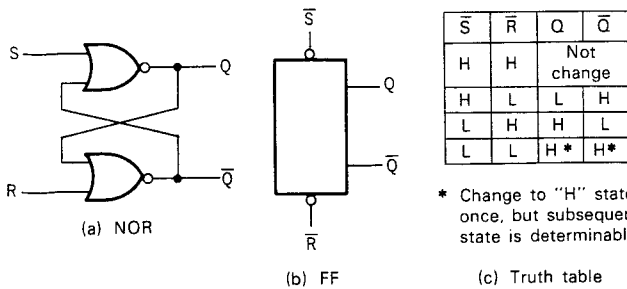


Fig. 2-15

### Latch

A latch stores information temporarily and consists of two 2-input gates as shown in Fig. 2-16. It is a kind of memory.



\* Change to "H" state once, but subsequent state is determinable.

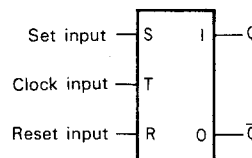
Fig. 2-16

### RST-FF

RST-FF operates as shown in Fig. 2-17. RST-FF has a clock input T in addition to the S and R inputs and the Q and Q outputs.

RST-FF does not operate according to the truth table and remain in its same state even if only R and S signals are applied. If changes the state according to the truth table when a clock pulse is applied to the T input.

#### Definition of RS-FF



(a) Symbol

tn	tn+1	
Input	Output	
S	R	Qn+1
① L	L	Qn
② H	L	H
③ L	H	L
④ H	H	☆☆

tn: Bit time before clock  
tn+1: Bit time after clock  
Qn: Remain its same state before clock  
☆☆: Indeterminate "H" or "L"

## LOGIC CIRCUIT DESCRIPTION

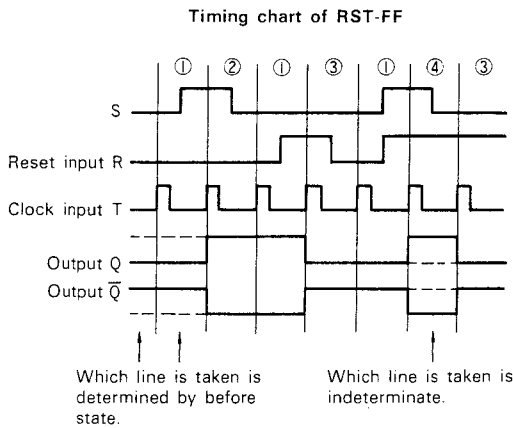


Fig. 2-17

When a clock pulse is applied to the T input while the S input is "H", the Q output will be "H" and  $\bar{Q}$  be "L". When a clock pulse is applied while the R input is "H", the Q output is set to "L" and  $\bar{Q}$  to "H". When a clock pulse is applied while the R and the S inputs are both "L", RST-FF will remain its same state. When a clock pulse is applied while both R and S inputs goes to "H", the Q and  $\bar{Q}$  outputs are complementary but which state is taken is indeterminate.

RST-FF is configured by adding two NAND gates to RS-FF.

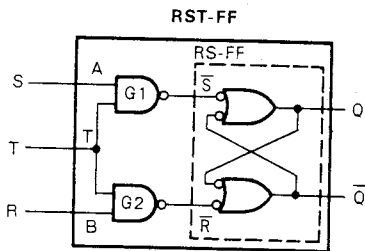


Fig. 2-18

Considering the  $\bar{S}$  and  $\bar{R}$  inputs of the RS-FF part, a NAND signal of A and T is applied to the  $\bar{S}$  input and a NAND signal of the B and T inputs is applied to  $\bar{R}$ . Now, let us consider what happens when a clock pulse of "L" or "H" is applied to the T input.

When the T input is "L":

Both S and R inputs goes to "H" and both A and B inputs do not affect the state of RS-FF part. That is, FF will remain in its present position.

When T is "H":

The A and B inputs are as well as affect  $\bar{S}$  and  $\bar{R}$ , respectively. Therefore, relation among A, B, Q and  $\bar{Q}$  is as shown in the truth table of RS-FF and A and B may be called S (set input) and R (reset input), respectively.

When the state of R changes while T is "H", Q and  $\bar{Q}$  change according to the truth table of RS-FF.

When T changes from "L" to "H":

The R and the S inputs immediately before the change are input and the Q and  $\bar{Q}$  outputs are according to the truth table.

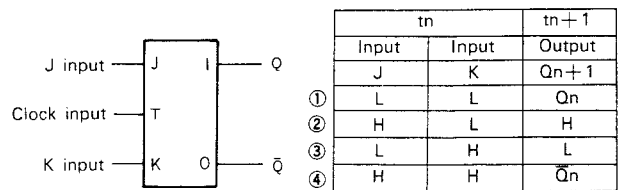
When T changes from "H" to "L":

The state immediately before the change is maintained.

### JK-FF

JK-FF has J and K inputs instead of S and R inputs of RST-FF.

When a clock pulse is applied to the T input while the J input goes to "H", the Q output will be "H" and  $\bar{Q}$  be "L". When a clock pulse is applied while the K input is "H", the Q output will be "L" and the  $\bar{Q}$  output be "H". When a clock pulse is applied while both input J and K are made "L", the state before the clock is maintained. When a clock pulse is applied while J and K are both "H", the state before the clock is inverted.



(a) Symbol

Note:  $t_n$ : Bit time before clock  
 $t_{n+1}$ : Bit time after clock  
 $Q_n$ : Remains its same state  
 $\bar{Q}_n$ : Changes state before that

(b) Truth table

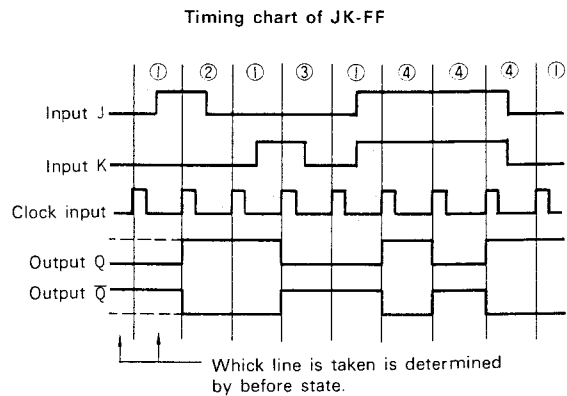
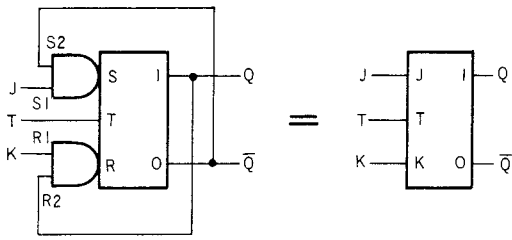


Fig. 2-19

The state of JK-FF is determinable when clocked while J and K are both "H", though the state of RST-FF is indeterminate when clocked while S and R are both "H".

JK-FF can be configured with RST-FF as shown in Fig. 2-20.

## LOGIC CIRCUIT DESCRIPTION



Configuration of JK-FF using RST-FF

Fig. 2-20

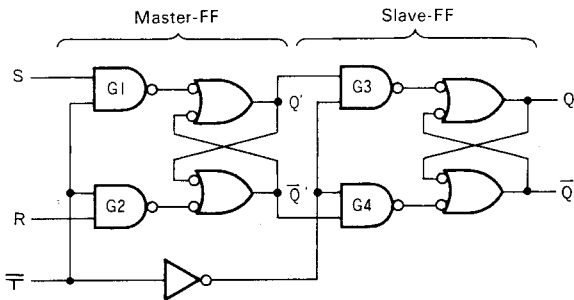
Assume that Q output is "H" and  $\bar{Q}$  output is "L". Since Q must be set to "L" and  $\bar{Q}$  to "H" when clocked, "L" level must be applied to the S input and "H" level to R input.

Otherwise, since Q output must be set to "H" and  $\bar{Q}$  output to "L" when clocked while Q output is "L" and  $\bar{Q}$  output is "H", "H" level must be applied to the input S and "L" level to the input R.

To meet the above requirements, two AND gates are connected with RST-FF to feed back the outputs, the outputs Q and  $\bar{Q}$ , to the set and reset inputs.

### Master-Slave FF

The master-slave FF consists of a master FF and a slave FF as the name indicates.



RST-FF with master-slave

Fig. 2-21

As shown in Fig. 2-21, the clock signal  $\bar{T}$  is applied to the master FF and the inverted  $\bar{T}$  is applied to the slave FF.

When the input  $\bar{T}$  is "L", "L" level is applied to the inputs of G1 and G2 of the master FF, so that the master FF's output will remain in its same state regardless of the inputs of S and R. And, "H" level is applied to the inputs of G3 and G4 of the slave FF, so that the master FF output state is given to the slave FF and the slave FF operates according to the truth table of RST-FF.

When the input  $\bar{T}$  is "H", the input state of R and S is given to the master FF and the master FF operates according to the truth table. However, the slave FF is not given the master FF output state because "L" level is applied to G3 and G4, so that the state of slave FF's output will remain in its same state.

When the input  $\bar{T}$  changes from "L" to "H", the master FF reads the input state of R and S but the slave FF is inhibited to read the output state of the master FF.

When the input  $\bar{T}$  changes from "H" to "L", the master FF is inhibited to read the input state of R and S, and the slave FF is allowed to read the output state of the master FF, that is, the outputs Q and  $\bar{Q}$  are set according to the truth table at this time.

In the above explanation,  $\bar{T}$  represent that Q and  $\bar{Q}$  change when the clock pulse changes from "H" to "L".

IC SN7473 (which is a JK-FF) has a reset input, R. When this input is set to "L", outputs Q and  $\bar{Q}$  are determined regardless of any other inputs and in the absence or presence of a clock pulse.

In the practical circuit, a capacitor is connected to the reset input so that 33-1/3 rpm is selected at STOP whenever the power is turned on.

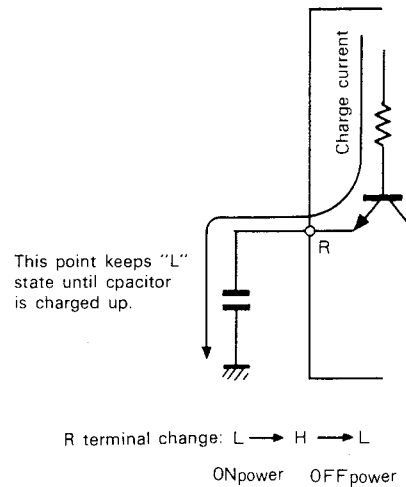
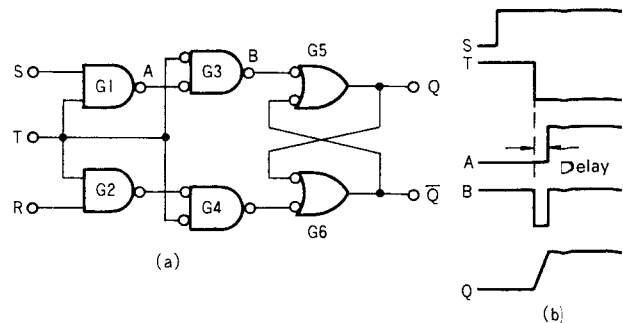


Fig. 2-22

### Edge Trigger

The pulse width of clock input is reduced in the FF circuit and the input is inhibited immediately after the outputs, the outputs Q and  $\bar{Q}$ , are set.



RS-FF with edge trigger

Fig. 2-23

## LOGIC CIRCUIT DESCRIPTION

Let the input S be "H" and the input R be "L". When the input T changes from "H" to "L", the waveform of G1 output, A, is as shown in Fig. 2-23 (b). This waveform is gate-delay-time behind the input T. A pulse corresponding to the delay time appears on the G3 output, B. The pulse is given to G5 to set the output Q to "H".

Thus, there are no limitation of width of the clock pulse. In this example, FF is triggered with an negative-going edge of the T clock-pulse input, therefore this trigger is called negative edge trigger.

Kind of FF	Clock Input Symbol	Logic Symbol	Clock Timing to Change State	Operation
Master Slave (Positive Going Trigger)	T			Input is read while clock is "L" (thick line) and output changes according to truth table when the clock pulse starts positive.
Master Slave (Negative Going Trigger)	$\bar{T}$			Input is read while clock is "H" (thick line) and output changes according to truth table when the clock pulse starts negative (arrow).
Edge Trigger (Positive Going Trigger)	T			When clock pulse starts positive, input is read and output changes according to truth table.
Edge Trigger (Negative Going Trigger)	$\bar{T}$			When clock pulse starts negative, input is read and output changes according to truth table.

Note: Thick lines indicate input reading timing and arrows indicate output changing timing.

< Table 2-1 >

### One-shot Multivibrator (SN74121)

IC6 and IC7 are used to generate the braking signal. When the PLAY/STOP button or the 33-1/3 or 45 rpm button is depressed to generate the braking signal, the pulse width must be determined, because the braking signal may be generated by change of the input signal. That is, a pulse of any width must cause a certain output signal of IC6 and 7.

For this purpose, the one-shot multivibrator is used and it operates according to the truth table in Fig. 2-24.

Input			Output	
A1	A2	B	Q	$\bar{Q}$
L	-	H	L	H
-	L	H	L	H
-	-	L	L	H
H	H	-	L	H
H	H	H	L	H
H	H	H	L	H
H	H	H	L	H
H	H	H	L	H
H	H	H	L	H
L	-	-	L	H
-	L	-	L	H
-	-	L	L	H
-	-	-	L	H

Waveform of figure is generated at the positive going edge of pulse.

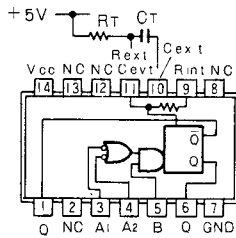
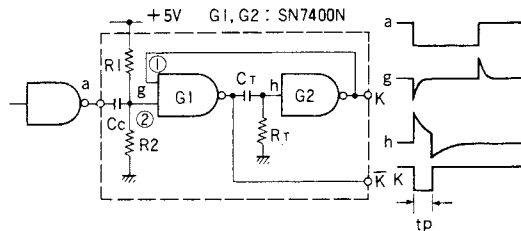


Fig. 2-24

### Operation

When a trigger pulse is applied to an input of G1, the output of G1 is set to "H". The output of G1 is connected to the input of G2 via a time constant circuit consisting of  $C_T$  and  $R_T$ , so that the input level of G2 changes negative as  $C_T$  is charged. In this period, the output of G2 (K) changes negative and positive and generates the pulse having pulse width  $t_p$ .



Monostable multivibrator using NAND gate

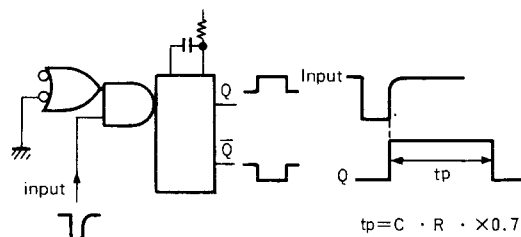
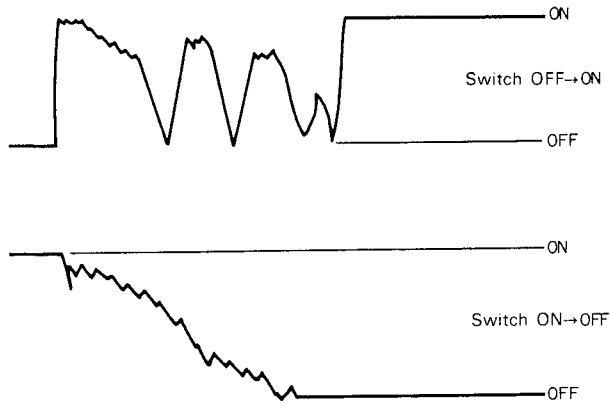


Fig. 2-25

## LOGIC CIRCUIT DESCRIPTION

### Chattering

A mechanical switch does not desirably operate when it is turned ON/OFF. Bounds of contacts or electric sparks may be caused.



Chattering  
Fig. 2-26

Since KD-750 handles digital signals, chattering may cause a misoperation. A latch circuit is used for switching to eliminate chattering.

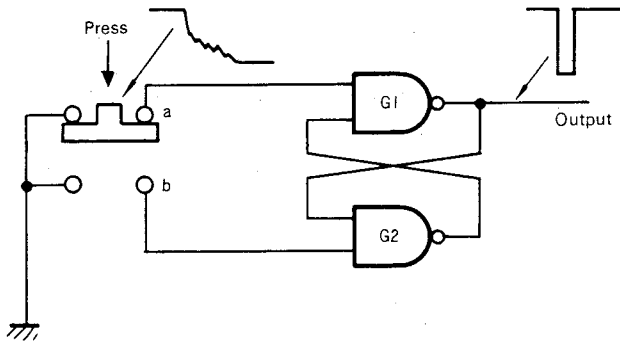


Fig. 2-27

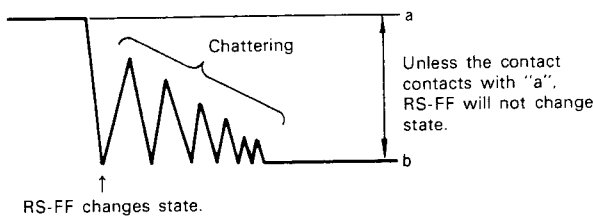


Fig. 2-28

When the pushbutton is at "a", the output is "H". When at "b", the output is "L". When in-between, the FF will remain in its same state (e.i. STOP or 33-1/3 rpm position).

### LOGIC CIRCUIT OPERATION OF KD-750

Rotation of motor, phase comparison and logic circuit are described in the previous sections. Now, let us understand the operation of KD-750, referring the block diagrams, on page 16.

#### POWER Switch ON

When the POWER switch is turned ON, KD-750 is placed in the STOP condition regardless of PLAY/STOP button position. Pin 2 of IC5 forces the turntable to be in the STOP condition. The 33-1/3/45 rpm selection is also forced to be in 33-1/3 rpm (by pin 6 of IC5).

#### PLAY

In 33-1/3 rpm condition, when the PLAY button is depressed, a pulse without CHATTERING is applied to pin 1 of IC5, master slave FF. The output Q is connected to pin 13 of IC15 and pin 9 of IC17. The IC15 is used to generate the braking signal when the rotation selection is changed from 45 rpm to 33-1/3 rpm. The IC17 lights the lock indicator on. The output Q is used to judge PLAY/STOP condition.

The other output  $\bar{Q}$  is connected to pin 2 of IC15, pin 5 of IC6, and pin 9 of IC4. The signal applied to IC15 is the signal deciding rotational direction and the signal applied to IC4 is used for the motor driving signal.

Level discussion is as follows. When the negative-going edge occurs as shown in Fig. 2-29, the output Q of IC5 goes to "H" state and  $\bar{Q}$  to "L" state.

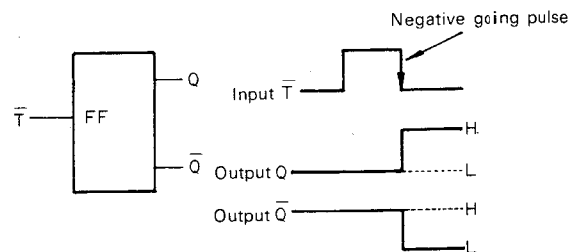


Fig. 2-29

The output Q of IC5 is connected to pin 13 of IC15, so that an input of IC15 is "H". The other input pin 12 of IC15 is "L" when turntable is set to 33-1/3 rpm. The output 11 of IC15 will be "H" and is connected to pin 5 of IC15. The output Q of IC5 is also connected to pin 9 of IC17, so that an input of IC17 is "H". The other input, pin 10 of IC17, is provided with the S-V signal. When the pin 10 of IC17 goes to "H", the output, pin 8 of IC17 is set to "L". This "L" level is applied to pin 12 of IC8. Pin 11 of IC8 is applied to 0 when the FG output and the standard signals are phase-locked. Then, Q4 and 5 are turned ON and OFF repeatedly. Thus, the indicator seems to be lit on. If the FG signal and the standard signal are not perfectly locked, unsettled pulses are applied to pin 11 of IC11, so that the indicator lights on and off.

## LOGIC CIRCUIT DESCRIPTION

The output  $\bar{Q}$  of IC5 is connected to pin 2 of IC15. Pin 1 of IC15 is given the output Q of IC6. Since IC6 changes state with a positive going edge, Q maintains "L" even if a negative going edge is given to pin 5. Therefore, pin 3 of IC15 is set to "H". Since pin 3 of IC15 is "H", the output pin 6 is set to "L". Then, pin 10 of IC15 is "L", so that pin 8 is set to "H". The output signal of pin 8 of IC15 is divided to three circuits.

One is given to the motor driving circuit as normal rotation signal. Other one is used as reversing signal of rotation for braking. The last one is used to direct whether the motor rotates or stops.

"H" level from pin 8 of IC15 is given to pin 11 of IC12 so that a clockwise rotation signal is obtained. The reverse rotation circuit is given "L" level through an inverter so that motor rotation is free direction. Since pin 9 of IC4 is "H" and pin 10 is "L", pin 8 is "H". This "H" level is inverted and then used to start the motor. Thus, the motor starts to rotate clockwise.

### 33-1/3 rpm

When the power is turned ON, pin 9 and pin 8 are set to "L" and "H", respectively, regardless of input signal to pin 5. Pin 9 output of IC5 is applied to the base of Q2 via a diode.

The output is also applied to IC4 and IC8 to judge turn speed whether turntable platter is poor speed or not.

Since pin 9 output is "L", the diode is forward-biased and Q2 is cut off.

The other output,  $\bar{Q}$ , of pin 8 of IC5 is applied to IC7 and is also given to the base of Q3 via a diode.

Since pin 8 output is "H", the output Q of IC7 is "L". This "L" signal is applied to pin 12 of IC15 and the resulted output is used for the pin 5 input of IC15 described in paragraph, PLAY. The diode connected to the base of Q3 is reverse-biased, so that Q3 is ON. A resistor connected to the emitter of Q3 and a capacitor of 100  $\mu$ F across pin 10 and pin 11 of IC7 determine the width of pulse for prevent reverse rotation.

Value of resistor connected to the emitter of Q2 is different from that of Q3 because the braking time for 45 rpm must be different from that for 33-1/3 rpm.

An analogue signal from the S-V converter is applied to pin 8 of IC16. There are 5 outputs on IC16. These output levels are as shown in Table 2-2.

	33 1/3 rpm	45 rpm
Q 1	L	L
Q 2	L	L
Q 3	L	H
Q 4	H	H
Q 5	H	H
	600~800mV	400~600mV

< Table 2-2 > Output level of IC16

On 33-1/3 rpm, Q3 is "L", so that pin 1 and 2 of IC4 are both "L". Since pin 3 of IC4 is "H", pin 8 of IC8 and pin 4 of IC4 are "H". Pin 8 and 9 are "H" and "L" respectively. Therefore, pin 10 of IC8 is "L". Since pin 12 and 13 of IC4 are both "L", pin 11 is "H". This "H" level is inverted and then applied to pin 2 of IC8.

Since pin 4 and 5 of IC4 are both "H", pin 6 is "L". When pin 5 and 6 of IC8 are both "L", pin 4 is "H". This "H" level is applied to pin 3 of IC8. When pin 2 of IC8 is "L" and pin 3 is "H", pin 1 is "L". Pin 12 and 13 of IC17 are connected to pin 1 of IC8, so that pin 11 of IC17 is "H", then pin 10 of IC17 is "H". When pin 9 and 10 of IC17 are both "H", pin 8 is "L". This output of pin 8 is used for lock indicator as shown in the previous section.

### 45 rpm

When speed selector is changed from 33-1/3 rpm to 45 rpm, a pulse without chattering is applied to pin 5 of IC5, then IC5 changes state as Q is "H" and  $\bar{Q}$  is "L". "H" level of Q turns Q2 ON to change the pulse width for braking. The output Q is also applied to IC4 and IC8 to indicate that turn speed is changed to 45 rpm.

"L" level of  $\bar{Q}$  cuts Q3 OFF. It is also applied to pin 5 of IC7 to maintain the output  $\bar{Q}$  of IC7 "L".

On 45 rpm, the output Q3 of IC16 is "H", so that pin 1 and 2 of IC4 are both "H". Therefore, pin 8 and pin 9 of IC8 are both "L" and pin 10 is "H". Then, pin 12 and 13 of IC4 are both "H" and pin 11 is "L". This "L" level is inverted and then applied to pin 2 of IC8.

Since pin 4 of IC4 is "L" and pin 5 is "H", pin 6 is "H". Since pin 5 and 6 of IC8 are both "H", pin 4 is "L". This "L" level is applied to pin 3 of IC8.

Since pin 2 of IC8 is "H" and pin 3 is "L", pin 1 is "L". This "L" signal operates the indicator circuit in the same way as 33-1/3 rpm.

### 45 rpm to 33-1/3 rpm

When turn speed changes from 45 rpm to 33-1/3 rpm, a pulse is applied to pin 5 of IC5, and Q changes from "H" to "L" and  $\bar{Q}$  from "L" to "H".

The output Q turns Q2 from ON to OFF so that the pulse width for braking at time when power switch is pressed to stop condition. The pin 9 output is also applied to IC4 and IC8 to indicate change of turn speed.

The pin 8 output of IC5 is applied to pin 5 of IC7. When the positive-going edge occurs, IC7 is triggered and outputs a pulse of a time determined by 33  $\mu$ F and 33 k $\Omega$  for braking signal.

Pin 12 of IC15 changes from "L" to "H", then pins 12 and 13 of IC15 are both "H" and pin 11 is "L". Since pin 5 is "L", pin 6 of IC15 is "H". Then, pin 9 and pin 10 of IC15 are both "H" and pin 8 is "L". This "L" signal directs counterclockwise rotation of the motor.

## LOGIC CIRCUIT DESCRIPTION

### STOP

When STOP button is pressed to stop the turning of turntable platter, a pulse is applied to pin 1 of IC5, and Q changes negative-going signal and  $\bar{Q}$  positive-going signal.

Q is applied to pin 9 of IC17 to turn the lock indicator off.

$\bar{Q}$  is applied to pin 9 of IC4.  $\bar{Q}$  is also applied to IC15 and IC6. IC6 generates a certain width of pulse (determined by 100  $\mu$ F and either of emitter resistors of Q2 or Q3).

Since pin 2 of IC15 is "H", the output is determined by the pin 1 input of IC15. Pin 1 of IC15 changes as "L"  $\rightarrow$  "H"  $\rightarrow$  "L".

When the STOP button is depressed, that is, the output Q of IC6 changes from "L" to "H", pin 3 of IC15 is set to "L". Then, pin 4 of IC15 is "L" and pin 5 of IC15 is "H", so that pin 6 of IC15 is "H". Since pin 10 and pin 9 of IC15 are both "H", pin 8 of IC15 is "L". Thus, the counterclockwise rotation signal is generated. Since pin 9 and pin 10 of IC4 are both "L", pin 8 of IC4 is "H". This "H" level is inverted and directs rotation. That is, the motor intends to rotate reversely for braking.

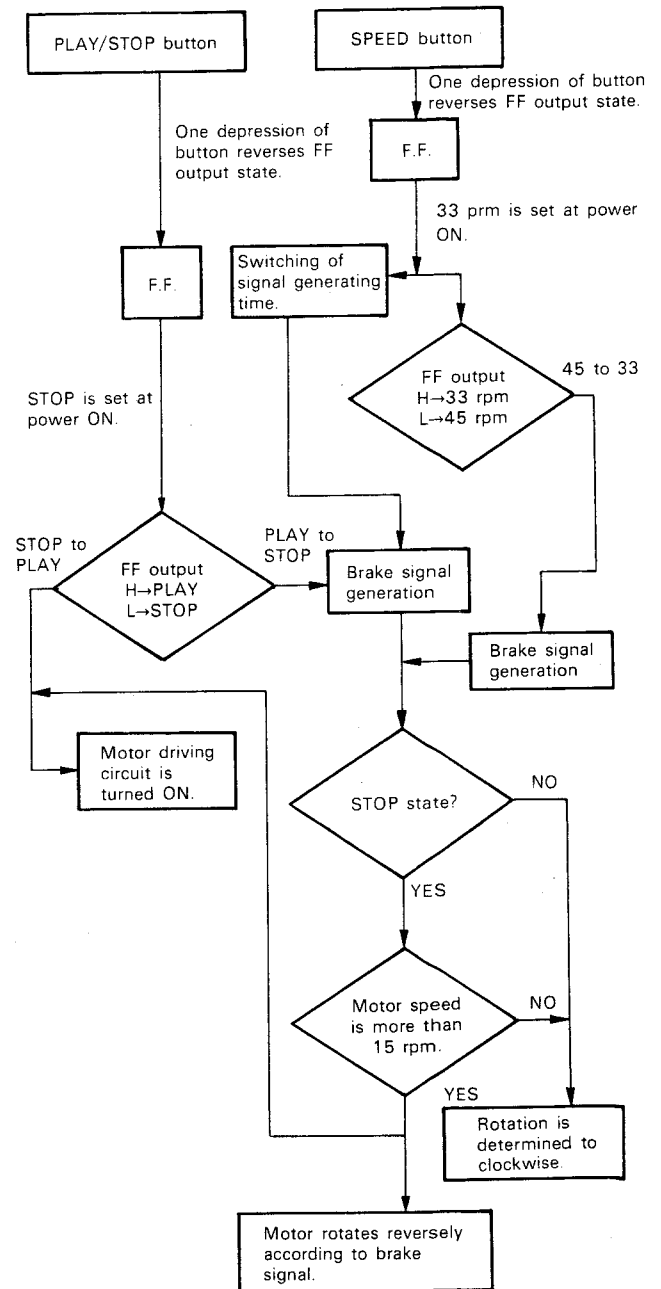
When the output Q of IC6 returns to "L", pin 3 of IC15 is set to "H". Since pin 4 and pin 5 of IC15 are both "H", pin 6 is "L". Since pin 9 and pin 10 of IC15 are both "L", pin 8 of IC15 is "H". Thus, the clockwise rotation signal is generated. Since pin 10 and pin 9 of IC4 are both "H", pin 8 of IC4 is "L" and pin 6 of IC11 is "H". Thus, the STOP signal is generated and the motor stops.

### Others

The turntable does not rotate reversely even if the STOP button is depressed while the turntable is forced to stop by hand on PLAY operation. When the turntable is stopped on PLAY operation, pin 9 of IC15 is set to "L" and the STOP signal is generated to stop the motor.

### BRAKE CIRCUIT

The PLAY/STOP switching and the 33-1/3 (rpm)/45 (rpm) speed switching work with a feather touch. The lock indicator circuit is provided.



# ONEARM DESCRIPTION

**Caution**  
 Tonearm (P26~28) and pick-up lead wire (P32) are explained. Their description is omitted as they are not applicable to KD-750.

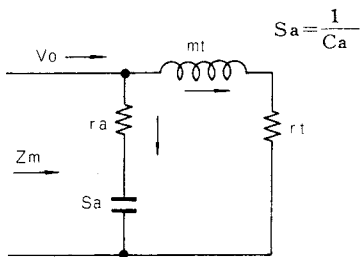
## ONEARM

Two big problems on tonearm are tonearm resonance curve and partial resonance caused by lack of stiffness of components.

### Tonearm Resonance

A basic equivalent circuit of tonearm for a low frequency range is as shown in Fig. 3-1. This equivalent circuit resonates at  $f_0$ :

$$f_0 = \frac{1}{2\pi} \times \sqrt{\frac{S_a}{m_t}} = \frac{1}{2\pi} \sqrt{\frac{1}{m_t \cdot C_a}} \dots\dots\dots (1)$$



- Vo: Velocity amplitude of record groove.
- Zm: Mechanical impedance in view of stylus.
- Sa, ra: Equivalent stiffness and resistance of support of vibration system.
- mt: Equivalent mass of tonearm included cartridge.
- rt: Equivalent resistance of tonearm fulcrum.

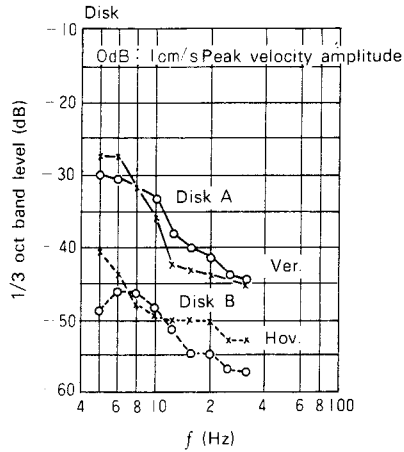
Equivalent circuit of pickup in low freq.

**Fig. 3-1**

This resonance is the tonearm resonance. Q indicating sharpness of resonance peak is given as:

$$Q = \frac{2\pi \cdot f_0 \cdot m_t}{r_a + r_t} \dots\dots\dots (2)$$

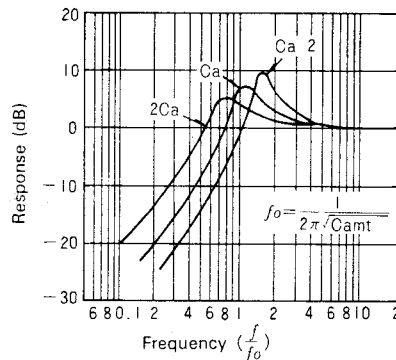
Generally, it is said that  $f_0$  should be in 7 ~ 12 Hz, so that noise caused by bend of disk and the turn of the motor is eliminated. Frequency characteristics and mechanical impedance characteristics in the case where  $C_a$ ,  $m_t$  and  $Q$  are changed are shown in Fig. 3-3 to 3-5.



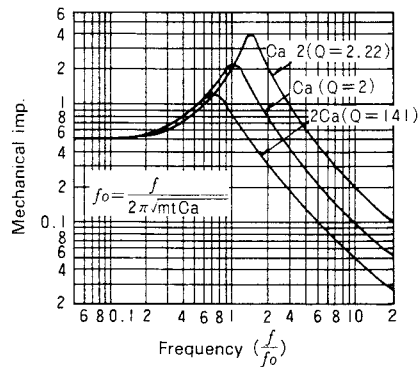
Frequency vs bent disk

**Fig. 3-2**

In Fig. 3-3, variation of  $C_a$  corresponds to replace cartridge. When value of  $C_a$  is large, the cartridge is a high compliance one. When value of  $C_a$  is small, a low compliance one. As known from eq. (1), tonearm resonance  $f_0$  decreases as the value of  $C_a$  increases.



Frequency characteristic when changing the value of  $C_a$ .

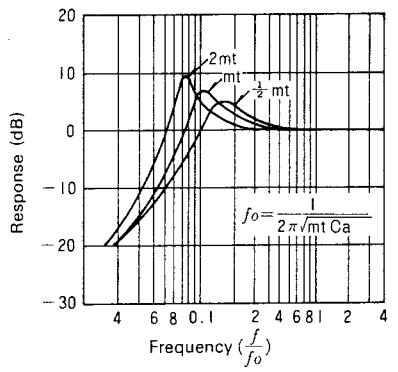


Mechanical impedance when changing the value of  $C_a$ .

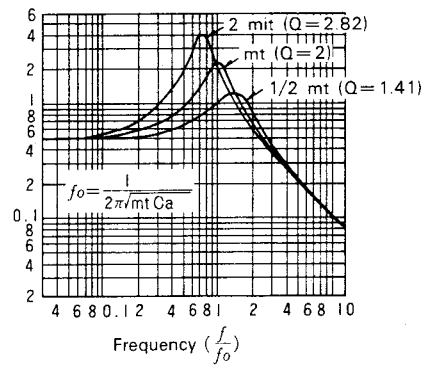
**Fig. 3-3**

## TONEARM DESCRIPTION

In Fig. 3-4, variation of  $mt$  corresponds to change of equivalent mass of tonearm. For tonearm such as an universal tonearm which uses uncertain cartridge, if the value of both  $mt$  and  $Ca$  are large,  $f_0$  decreases too much and inter-modulation distortion caused by bent and eccentricity disk may occur. The value of  $mt$  must be selected so that  $f_0$  is  $7 \sim 12$  Hz for all cartridges to be used.



Resonance frequency vs peak when changing the value of  $mt$ .

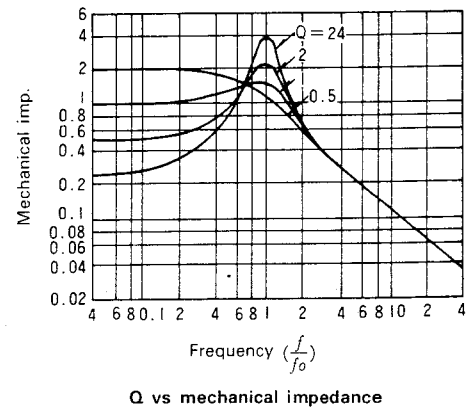
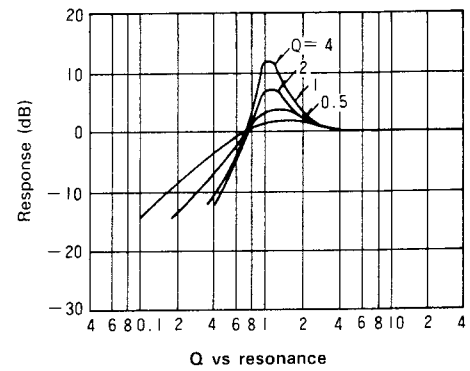


Mechanical when changing the value of  $mt$ .

**Fig. 3-4**

Characteristics in the case where  $Q$  is changed are shown in Fig. 3-5. If a cartridge and a tonearm to be used are determined, change of  $Q$  corresponds to variation of  $r_t$  (equivalent resistance of fulcrum of the tonearm). The value of  $mt$ ,  $Ca$ , and  $r_a$  in eq. (1) and eq. (2) are determined. A large increase of  $r_t$  result in decrease of  $Q$  of resonance peak but frequency characteristic at  $f_0$  or less falls down gradually and mechanical impedance increases. This is undesirable because bent and eccentric disk will be reproduced.

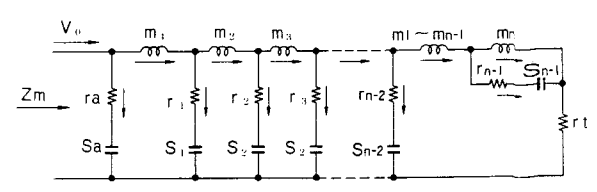
Tonearm, TA-71 which is used in KD-750, was designed to have an equivalent mass of 22g when a cartridge having 6g weight is attached, so that tonearm resonance,  $f_0$ , will be within  $7 \sim 12$  Hz even if any cartridge is attached. And,  $Q$  of resonance peak can be decreased by means of the flexible stand-off decoupling system described in the following, so that the stylus traces a groove on a record without affects of bend or eccentricity.



**Fig. 3-5**

### Partial Resonance

There may be a play between a shell and the Tonearm or between a shell and a cartridge, and stiffness of such component as shell and pipe may be lacked since a shell of an universal tonearm such as TA-71 is removable. These plays or lack of stiffness result in a dip of frequency characteristic curve. This dip is called "partial resonance". An equivalent circuit is shown in Fig. 3-6. If no "partial resonance" occurs, the curve will agree with Fig. 3-1.



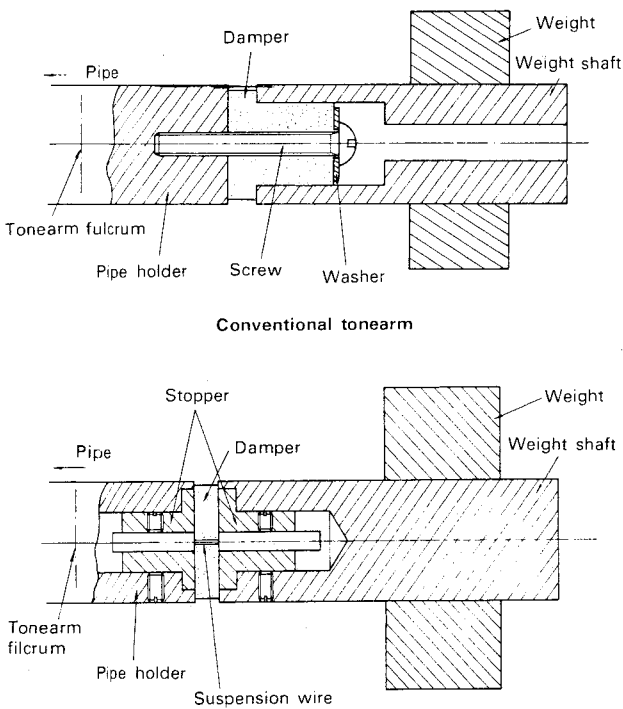
- $V_o$ : Velocity amplitude of record groove.
- $Z_m$ : Mechanical impedance in view of stylus
- $S_a, r_a$ : Equivalent stiffness and resistance of support of vibration system.
- $r_t$ : Equivalent resistance of tonearm fulcrum.
- $m_1 \sim m_{n-1}$ : Equivalent mass in view of stylus until stylus bar occurs partial resonance.
- $S_1 \sim S_{n-2}, r_1 \sim r_{n-2}$ : Equivalent resistance and stiffness of partial resonance section.
- $m_n$ : Equivalent mass of back of tonearm fulcrum.
- $S_{n-1}, r_{n-1}$ : Equivalent stiffness and resistance of partial resonance of back of tonearm fulcrum.

**Fig. 3-6**

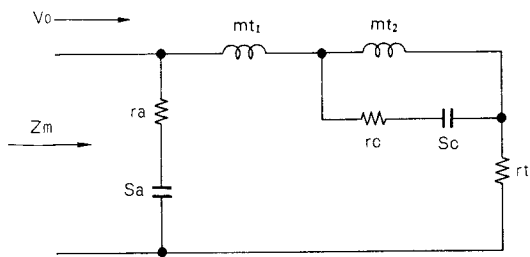
# TONARM DESCRIPTION

## Flexible Stand-off Decoupling Tonearm

A conventional weight attaching method is shown in Fig. 3-7. The weight shaft and weight correspond to  $mt_2$  in Fig. 3-8 and the damper corresponds to  $rc \cdot Sc$ . Since  $Sc$  cannot be decreased by this method, a partial resonance, is around  $50 \sim 150$  Hz. No large dip of frequency characteristic curve appears since  $rc$  is large, however dips affect cross-talk characteristic and etc. If dips appear, transient characteristic becomes worse, so that tone quality becomes worse and enough effect for howling can not be obtained.



TA-71  
Fig. 3-7



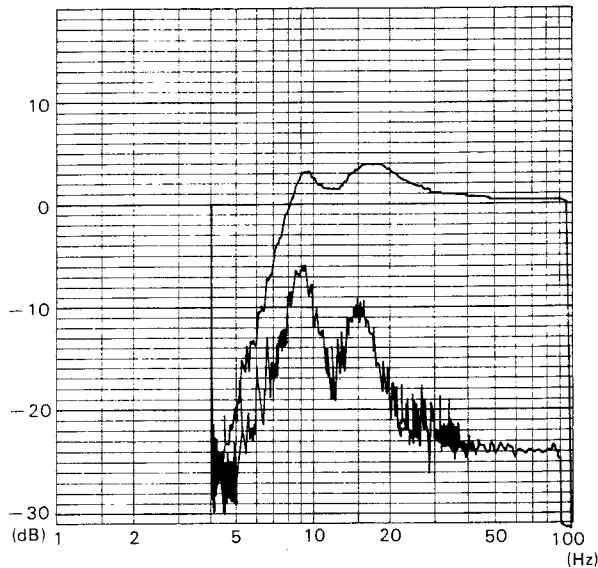
- $V_o$ : Velocity amplitude of record groove.
- $Z_m$ : Mechanical impedance in view of stylus.
- $S_a, r_a$ : Equivalent stiffness and resistance of support of vibration system.
- $r_t$ : Equivalent resistance of tonearm fulcrum.
- $mt_1$ : Equivalent mass of tonearm except weight.
- $mt_2$ : Equivalent mass of weight.
- $S_c, r_c$ : Equivalent stiffness and resistance of weight coupling.

Fig. 3-8

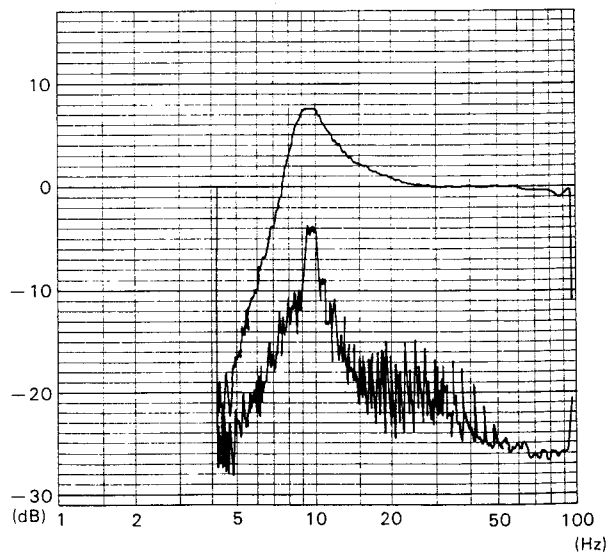
The coupling system is employed to decrease  $Sc$  extremely, lower a partial resonance, beyond audible frequency range so that it agrees with the tonearm resonance, and decrease  $Q$  of resonance peak utilizing phase difference.

In TA-71, a piano wire of a high elasticity is used for suspension wire, which acts as  $Sc$  in Fig. 3-8. And, butyl rubber of a high equivalent resistance is used for damper, which acts as  $rc$ .

Data by observation on TA-71 are shown in Fig. 3-9 where peaks of resonance are suppressed. These curves well represent features of the flexible coupling tonearm.



TA-71 Characteristic at low frequency region



Conventional tonearm characteristic at low frequency region

Fig. 3-9

## TONEARM DESCRIPTION

**Bearing**

TA-71 uses an angular contact bearing for vertical support and a radial bearing for horizontal support.  
 Compared data between TA-71 and the conventional our

products are shown in Table 3-1 and 3-2. Circularity and race roughness of radial bearing are shown in Fig. 3-10 ~ 3-12.

**RADIAL BEARING**

	Sample No.	Circularness ( $\mu$ )				Race roughness	
		Inner-diameter	Outer diameter	Race		Inside	Outside
				Inside	Outside		
Conventional	1	2.0	1.0	1.5	0.9	1.15 $\mu$ Rmax	0.6 $\mu$ Rmax
	2	2.2	1.0	0.9	0.8	1.4	0.85
	3	1.2	1.0	1.0	0.5	0.8	1.4
TA-71	1	0.5	0.3	0.4	0.4	0.17	0.15
	2	0.7	0.6	0.5	0.4	0.12	0.12
	3	0.8	0.3	0.5	0.4	0.15	0.20

< Table 3-1 >

**Angular contact bearing ( $\mu$ )**

Sample	Conventional	TA-71
1	0.16~0.18	0.11~0.12
2	0.2~0.21	0.08~0.09
3	0.14~0.15	0.12~0.13
4	0.18~0.19	0.12~0.13

< Table 3-2 >

As known from these tables and figures, bearings are super precision types, so that operation is smoothed, the supporting point does not shift, traceability is improved and partial resonance is suppressed.

# TO NEARM DESCRIPTION

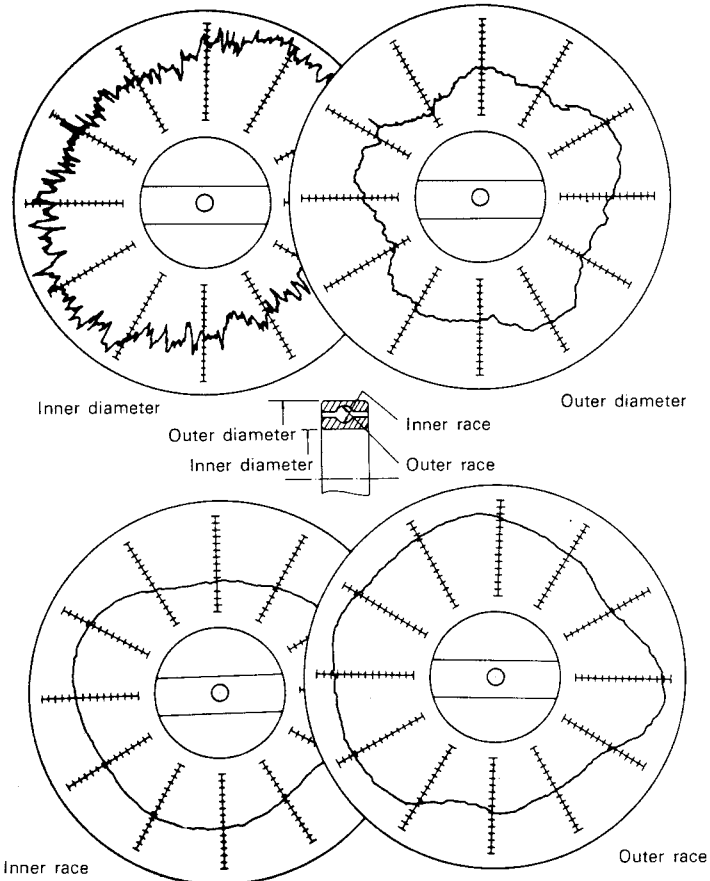


Fig. 3-10 Circularity for conventional radial bearing

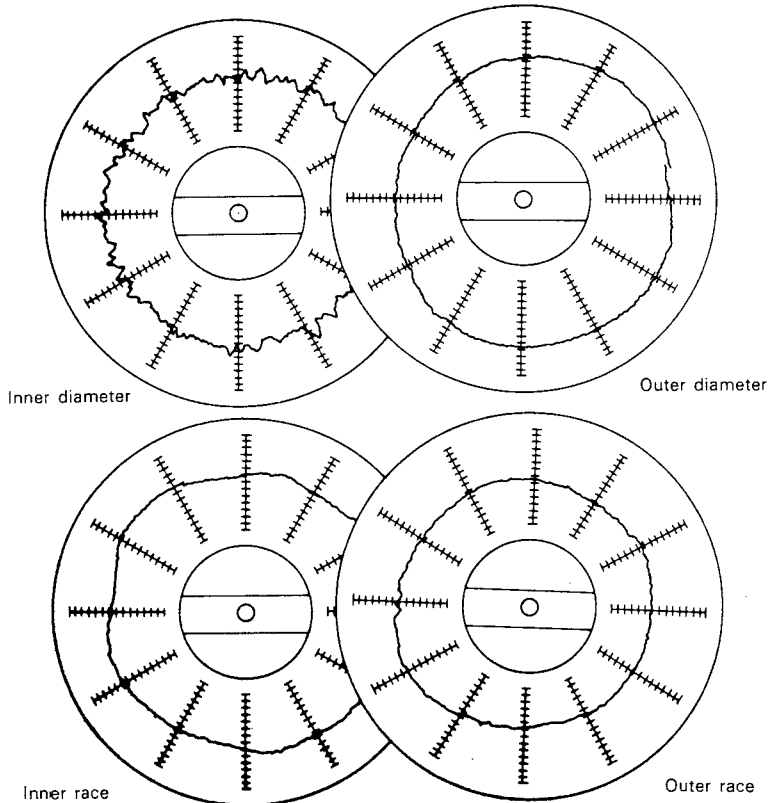
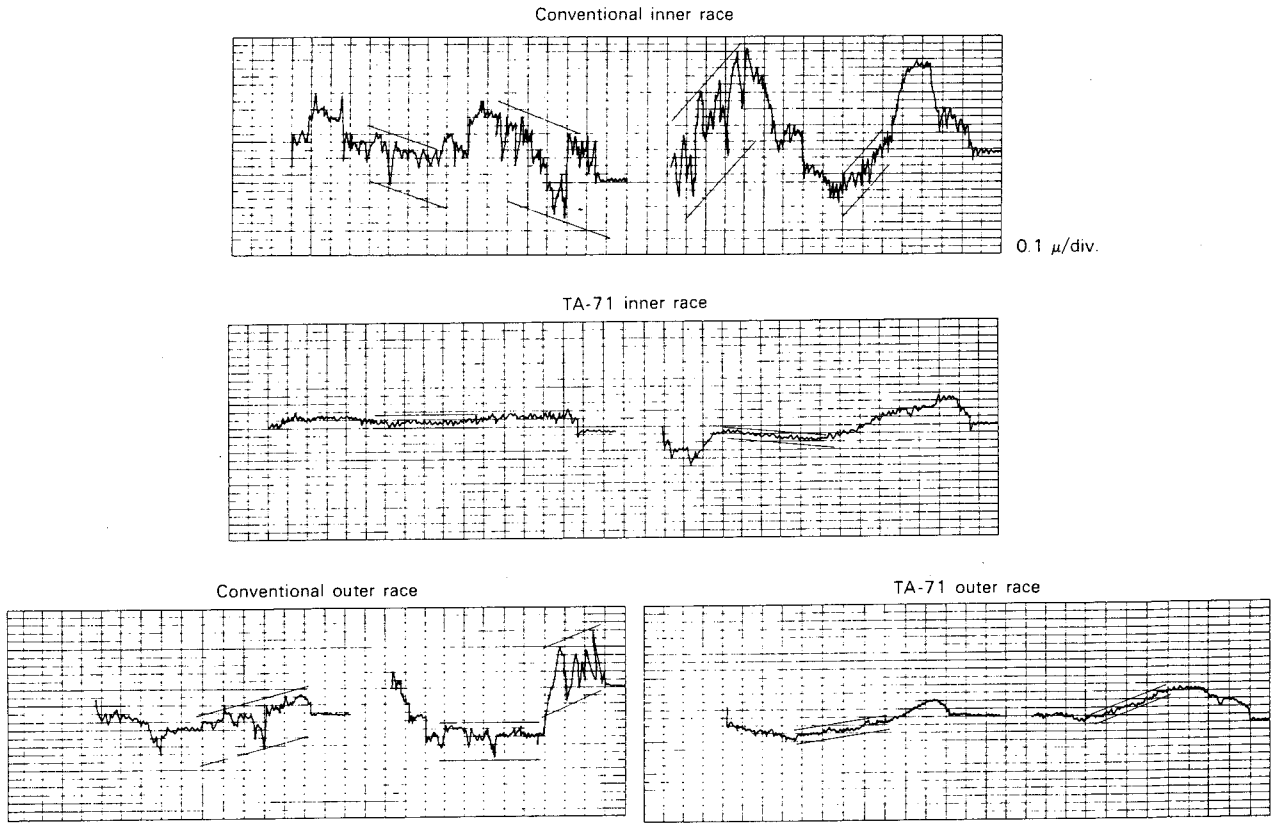


Fig. 3-11 Circularity for TA-71 radial bearing

## TONARM DESCRIPTION



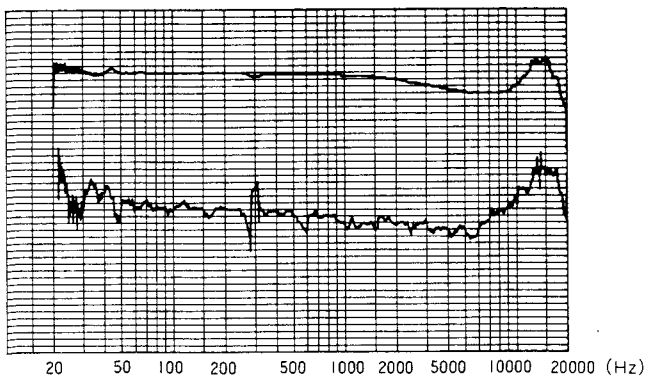
**Fig. 3-12** Surface roughness of race for conventional and TA-71

### Tonearm base

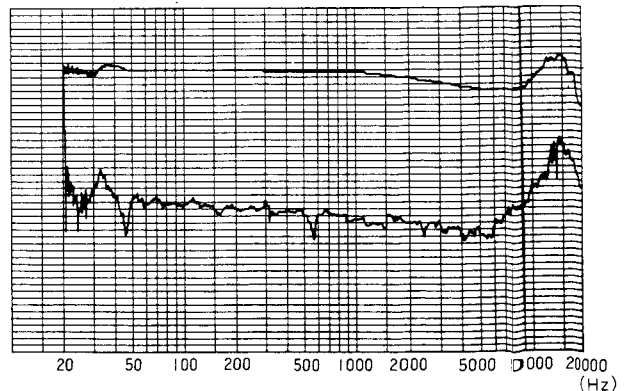
The conventional tonearm bases lack mechanical strength and fixing strength for tonearm. Therefore, if mechanical impedance of tonearm base seen from the tonearm supporting point is small, supporting point shift is liable to occur. As a result, partial resonance generated worsens transient characteristic.

KD-750 uses a collet chuck type tonearm base to increase mechanical impedance. Thus, the tonearm is securely fixed and supporting point shift is prevented.

Frequency characteristic of a conventional tonearm base is shown in Fig. 3-13. That of the collet chuck type tonearm base of KD-750 is shown in Fig. 3-14, where a partial resonance at 300 Hz is well suppressed.



**Fig. 3-13** Conventional tonearm base



**Fig. 3-14** KD-750 tonearm base

## TONARM DESCRIPTION/HEAD SHELL

### PICK-UP LEAD WIRE

The internal lead wires used in TA-71 are a low resistance, a low capacitance, and a low cross-talk wires as shown in Fig. 3-15. Comparison between this wire and a conventional vinyl wire is shown in Table 3-3.

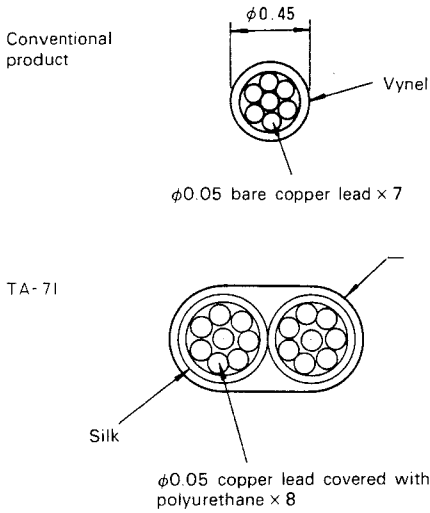


Fig. 3-15

	Conventional	TA-71
Resistance	0.36Ω/282 mm	0.173Ω/282 mm
Capacitance between wires in the air.	14.75 pF/282 mm	7.17 pF/282 mm
Capacitance between wires in pipe.	18.7 pF/282 mm	13.49 pF/282 mm

< Table 3-3 >

### HEAD SHELL

It has been said that the head shell affects tone quality. Because, the motor and the tonearm was improved and affect of head shell on tone quality has been closed up. The head shell of KD-750 was designed to meet these requirements.

#### Quality of Material for Head Shell

Materials for head shell is roundly divided into the following 6:

- 1) Plastics
- 2) Die Casting Aluminum
- 3) Molten Metal Forged Aluminum
- 4) Aluminum
- 5) Carbon Fiber
- 6) Magnesium

Among these, magnesium has a low specific gravity of 0.6 and a large mechanical strength compared to aluminum and has a better molding characteristic than carbon fiber.

The most fundamental requirement for head shell is mechanical strength. If mechanical strength is small, partial resonance will occur as shown in Fig. 3-16. It is also required to shift natural vibration frequency beyond audible frequency range.

A bar shown in Fig. 3-17 is assumed. Resonance frequency of the rod is given as follows.

$$f = \frac{\lambda^2}{2\pi \ell^2} \cdot \sqrt{\frac{EIg}{rA}} \dots\dots\dots(4)$$

- ℓ : Bar length
- f : Natural vibration of bar
- π : Dimensionless coefficient decided by vibration system and a/b
- E : Young's modulus
- g : 981 cm/S
- δ : Poisson's ratio
- r : Weight of unit volume

f is increased by making EI, which represents mechanical strength, larger. To increase mechanical strength of head shell whose weight is limited, the conventional of head shell must be considered.

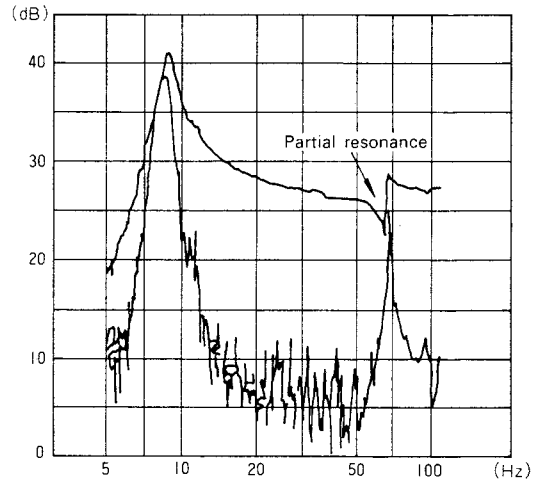


Fig. 3-16

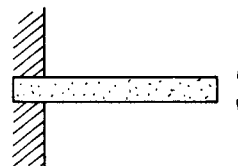
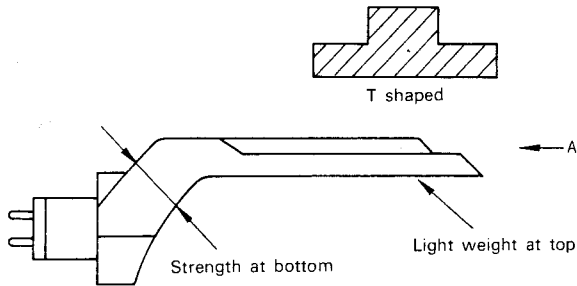


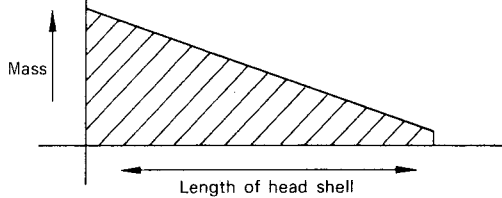
Fig. 3-17

## HEAD SHELL

The conventional head shell used in KD-750 is shown in Fig. 3-18. Mass distribution is shown in Fig. 3-19. As shown in the figures, the base part is thick, and the top is lightened and formed as T shape to increase mechanical strength. (See Fig. 3-20.)



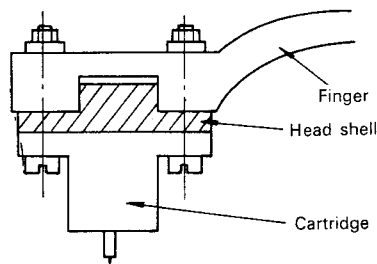
**Fig. 3-18**



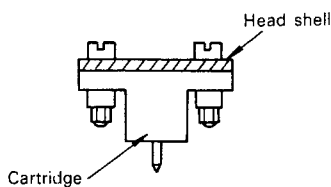
**Fig. 3-19** Ideal mass distribution

The headshell of KD-750 keeps fitting strength of cartridge as shown above.

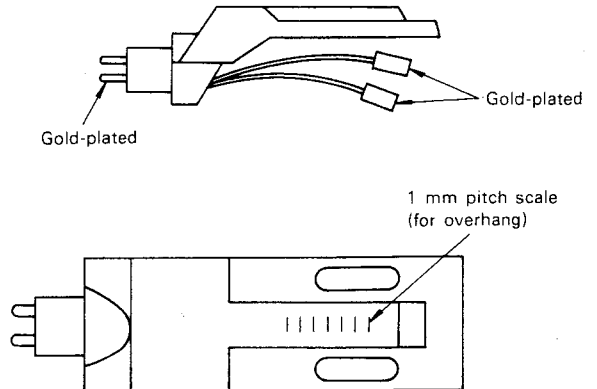
Cartridge fixing strength also must be considered. For the shell of KD-750, the fixing strength is increased by making the finger thick.



(KD-750)

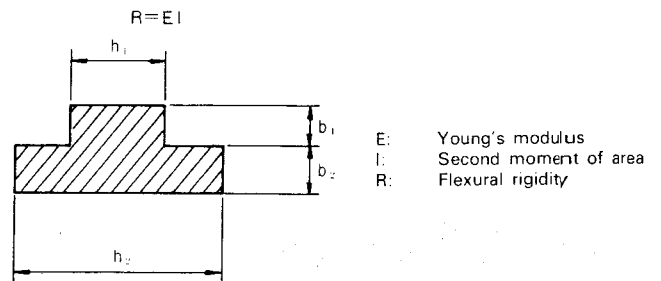


(Conventional)



**Fig. 3-20**

One of factors determining mechanical strength is flexural rigidity. Equation is given as follows.



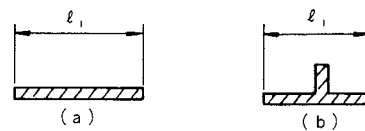
**Fig. 3-21a**

At this time,

$$I = \frac{1}{R} (b_1 h_1^3 + b_2 h_2^3)$$

To increase "flexural rigidity" R, second moment of area must be increased.

That is, for the below forms of a and b, when  $\ell_1 = \ell_2$ , and sectional areas and materials are same, b is stronger than a.



**Fig. 3-21b**

## AUDIO CORD / TURNTABLE SHEET

### AUDIO CABLE (OUTPUT CABLE)

Specifications of the output cable are shown in Table 3-4.

Conductor Resistance:	0.23 Ω/m max (20°C)
Shielding Wire Resistance:	0.035 Ω/m max
Capacitance between Conductor and Shielding Wire:	50 pF/m or less
Insulation Resistance between Conductor and Shielding Wire:	40 MΩ/m min
Dielectric Strength Test:	AC500V for 1 min
Earth Lead Resistance:	0.073 Ω/m max

< Table 3-4 >

Pin form of a former 5P connector is shown in Fig. 3-22. Such a pin is liable to slip out and contact resistance is ready to increase.

Our newly developed connector is improved in slipping-out and contact resistance, which is shown in Fig. 3-23.

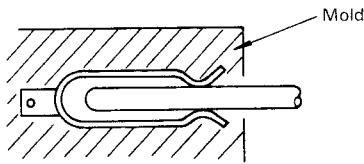


Fig. 3-22

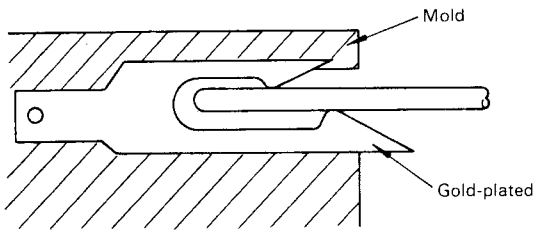


Fig. 3-23

### TURNTABLE SHEET

A table sheet is used for the following purposes.

- 1) to protect a record
- 2) to prevent a record slipping
- 3) to prevent vibration

Quality of material and structure greatly affect 2) and 3) above. For KD-750, 2) slip is prevented by flattening the surface of table sheet and 3) vibration is prevented by selecting material and by means of Helmholtz's theory.

#### Quality of Material for Turntable Sheet

Most of commercially available turntable sheet are made of,

- 1) natural rubber,
- 2) SBR
- 3) butyl rubber.

Requirements for quality of material are as follows.

- 1) shock absorption
- 2) vibration absorption
- 3) noise absorption
- 4) slip resistance
- 5) air permeability
- 6) weather proofing
- 7) thermal stability

For KD-750, materials and blending ratio were determined to be optimum.

Among these requirements, vibration absorption and slip resistance especially affect tone quality. If slip resistance is low, sound will be faded. Vibration absorption for each material is shown in Fig. 3-24. Difference of materials is cleared at resonance point of each material (natural vibration frequency of rubber is Low) but there is little difference among materials at a high frequency. Thus, no special effect is expected even if material is selected. To improve vibration absorption at high frequency range, KD-750 utilizes a Helmholtz's resonator for the table sheet.

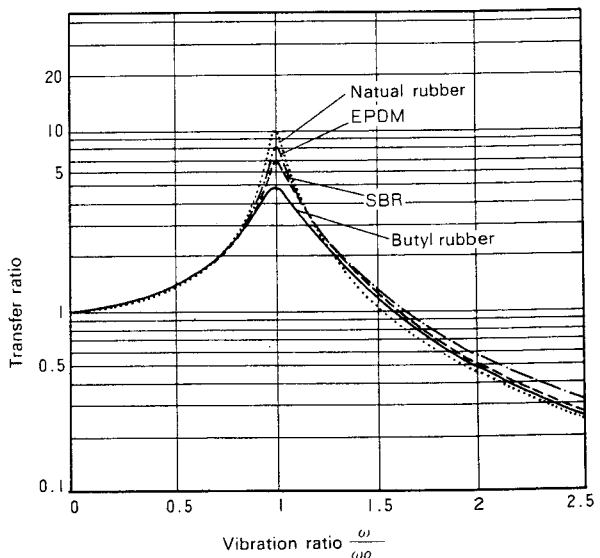


Fig. 3-24 Absorbability for vibration

# TURNTABLE SHEET

## Requirements of Vibration Absorption at High Frequency Range

A record is in complicated motion on a turntable sheet. Partial resonance occurs at high frequency range and deflection resonance occurs at low frequency range. These resonances are very complexed and affected by setting conditions of record.

When a record is set on a turntable, states shown in Fig. 3-25 ~ 3-27 may occur. Resonance frequency (deflection vibration frequency) of record on each setting condition is given as follows.

$$f_n = \lambda \sqrt{\frac{h}{4\pi a^2}} \sqrt{\frac{Eg}{3(1-\delta^2)r}} \dots\dots\dots(5)$$

- $\lambda$  : non-dimensional coefficient determined by setting condition and vibration mode
- $h$  : thickness
- $a$  : radius of record
- $E$  : elastic coefficient of record ( $3 \times 10^{10}$  dyne/cm<sup>2</sup>)
- $\delta$  : Poisson's ratio (0.45)
- $r$  : weight of unit volume (1.3 g/cm<sup>3</sup>)

For Fig. 3-25,  $f_0 \approx 10$  Hz. For Fig. 3-26,  $f_0 \approx 30$  Hz. From these, it is known that the lowest resonance frequency of record is from very low. And, resonance characteristic is very broad compared to the metal. In a condition of Fig. 3-27, little deflection resonance occurs but partial resonance due to acoustic pressure occurs. This resonance can not be indicated by a lot of equation because there are many un-specific setting conditions of table sheet, air layer and record. It is considered that partial resonance occurs at a frequency higher than 3 kHz. A record on a turntable is considered to be on an air layer at high frequency range. Vibration of this air layer caused by partial resonance must be absorbed. Thus, Helmholtz's theory is applied.

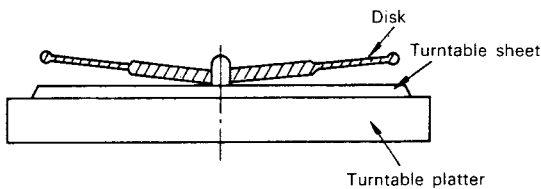


Fig. 3-25 Shaft section settled

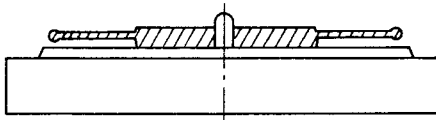


Fig. 3-26 Label section settled

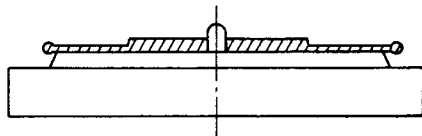


Fig. 3-27 Whole settled

## HELMHOLTZ'S RESONATOR

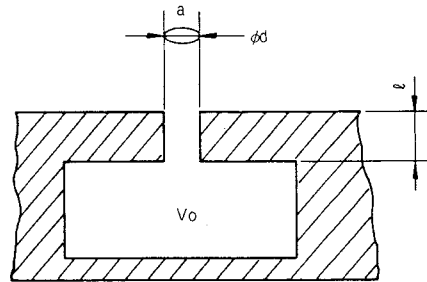
Helmholtz's resonator is also called whisky bottle resonator, and angular frequency is represented by eq. (6) and eq. (7).

$$\omega_0 = V \sqrt{\frac{a}{V_0 \ell}} \dots\dots\dots(6)$$

- $V$  : acoustic velocity
- $V_0$  : volume of cavity
- $a$  : area of neck
- $\ell$  : length of neck
- $\omega_0$  : angular frequency of resonator

From eq. (6), an experimental equation is given as

$$f = \frac{V}{2\pi} \sqrt{\frac{a}{V_0(\ell + 0.8d)}} \dots\dots\dots(7)$$



Resonator

Fig. 3-28

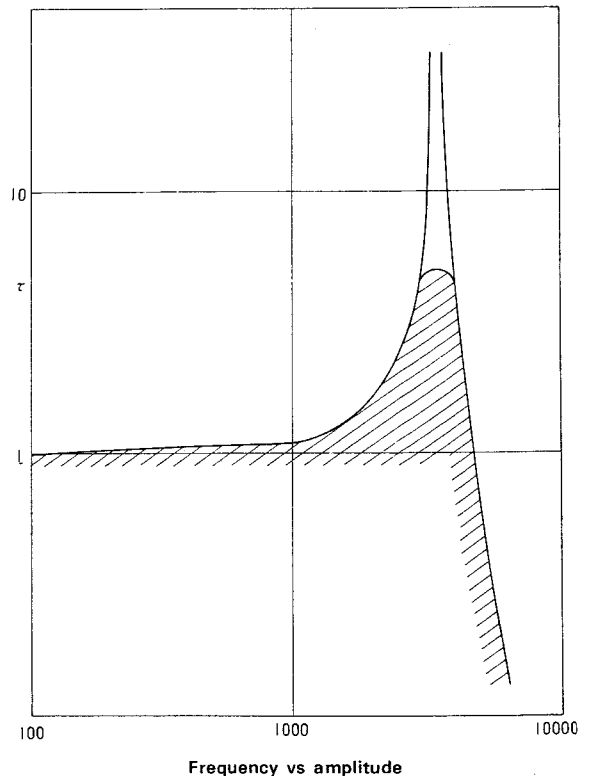


Fig. 3-29

## TURNTABLE SHEET

(Refer to Fig. 3-29, Resonance Characteristic)

A condition where a record is on a Hel-sheet (a sheet to which Helmholtz's theorem is applied) is shown in Fig. 3-30. Vibration of air caused by partial resonance of record is absorbed most effectively with a cavity including a big hole and a small hole when its resonance frequency agrees with the vibration frequency.

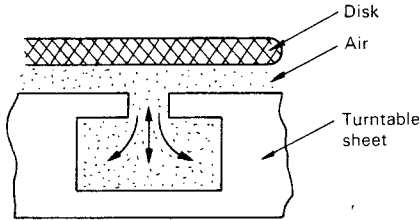


Fig. 3-30

Resonance frequency of the Hel-sheet was determined to 3.5 KHz. Actual effective range of partial resonance of record is considered to be over 1000 ~ 10 kHz. Increase of number of holes results in widening range of resonance. This is because partial resonance characteristic is broad.

The reason why resonance frequency was determined to 3.5 kHz is that the most of partial resonances of record were observed above 3 kHz by experiments.

### Distribution of Resonance Points by Equation

The Hel-sheet cants up by 30' toward center. Therefore, lengths of neck are different according to the distance from the center. Let lengths of neck be  $\ell_1, \ell_2, \ell_3, \ell_4$  and  $\ell_5$ , respectively.

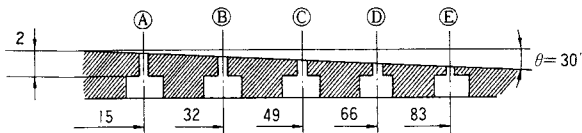


Fig. 3-31

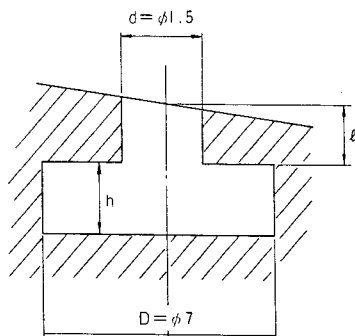


Fig. 3-32

$\ell_1$  is,

$$\ell_1 = 0.2 - 1.5 \times \tan \theta \quad \tan \theta = 30' = 0.00872686$$

The length is given as

Then,

$$\ell_1 = 0.2 - 1.5 \times 0.00873 \approx 0.1869$$

$$\ell_2 = 0.2 - 3.2 \times 0.00873 \approx 0.1721$$

$$\ell_3 = 0.2 - 4.9 \times 0.00873 \approx 0.1572$$

$$\ell_4 = 0.2 - 6.6 \times 0.00873 \approx 0.1424$$

$$\ell_5 = 0.2 - 8.3 \times 0.00873 \approx 0.1267$$

From eq. (7), resonance frequency,  $f_n$ , is given as

$$f_n = \frac{34000}{2\pi} \sqrt{\frac{a}{V(\ell + 0.8d)}} \text{ Hz} \quad (8)$$

where

$$a = \frac{\pi}{4} d^2 = \frac{\pi}{4} \times 0.15^2 = 0.01767 \text{ cm}^2$$

$$V = \frac{\pi}{4} D^2 h = \frac{\pi}{4} \times 0.7^2 \times 0.4 = 0.15386 \text{ cm}^3$$

No.	$\ell_n$ (cm)	$\ell_n + 0.8d$	$V(\ell_n + 0.8d)$	$\frac{a}{V(\ell_n + 0.8d)}$	$\sqrt{\frac{a}{V(\ell_n + 0.8d)}}$	$f_n$
Ⓐ	0.1869	0.3069	0.0472	0.3744	0.6119	3311.25
Ⓑ	0.1721	0.2921	0.0449	0.3935	0.6273	3394.59
Ⓒ	0.1572	0.2772	0.0426	0.4148	0.6440	3484.96
Ⓓ	0.1424	0.2624	0.0404	0.4374	0.6614	3579.12
Ⓔ	0.1276	0.2476	0.0381	0.4638	0.6816	3685.18

Ease of resonating is indicated by amplitude ratio,  $\tau$ .

$$\tau = \frac{1}{1 - \left(\frac{f}{f_n}\right)^2} = \frac{a}{a_0} \quad (9)$$

$\tau$  of No. 1 hole is calculated and shown in the following table.

**TURNTABLE SHEET**

f	$\frac{f}{f_n A}$	$\left(\frac{f}{f_n A}\right)^2$	$1 - \left(\frac{f}{f_n A}\right)^2$	$\tau = \frac{a}{a_0}$	$a^2$
100	0.0302	0.000912	0.99909	1.0009	1.0018
500	0.1510	0.02280	0.97720	1.0233	1.0471
1000	0.3020	0.091204	0.90800	1.10036	1.2108
1500	0.4530	0.20521	0.79479	1.2582	1.5831
2000	0.6040	0.36482	0.63518	1.5744	2.4787
2200	0.6644	0.44143	0.55857	1.7903	3.2052
2400	0.7248	0.52533	0.47467	2.1067	4.4382
2600	0.7852	0.61654	0.38346	2.6078	6.8006
2800	0.8456	0.71504	0.28496	3.4569	11.9501
3000	0.9060	0.82084	0.19716	5.0720	25.7252
3200	0.9664	0.93393	0.06607	15.1355	229.0834
3250	0.9815	0.96335	0.03665	27.2851	
3311.25	1.0000	1.00000	0.0000	$\infty$	
3350	1.01770	1.02354	0.02354	42.4801	
3400	1.0268	1.05432	0.05432	18.4094	338.9060
3600	1.0872	1.18200	0.18200	5.4945	30.1895
3800	1.1476	1.31699	0.31699	3.1546	9.9515
4000	1.2080	1.45926	0.45926	2.1774	4.7410
4200	1.2684	1.60883	0.60883	1.6425	2.6978
4400	1.3288	1.76571	0.76571	1.3059	1.7053
4600	1.3892	1.92988	0.92988	1.0754	1.1565
4800	1.4496	2.10134	1.10134	0.9079	0.8243
5000	1.5100	2.28010	1.12801	0.8865	0.7885
5200	1.5704	2.46616	1.46616	0.6821	0.4653
5400	1.6308	2.65951	1.65951	0.6026	0.36313
5600	1.6912	2.86016	1.86016	0.5375	0.28991
5800	1.7516	3.06810	2.06810	0.4835	0.2338
6000	1.8120	3.28334	2.28334	0.4379	0.1918
8000	2.4160	5.8371	4.8371	0.2061	0.04772
10000	3.0200	9.1204	8.1204	0.1234	0.01515

f	$a^2$	$\Delta W$
100	1.0018	100.18
500	1.0471	523.55
1000	1.2108	1,210.80
1500	1.5831	2,374.65
2000	2.4787	4,957.40
2200	3.2052	7,051.44
2400	4.4382	10,651.68
2600	6.8006	17,681.56
2800	11.9501	33,460.28
3000	25.7252	77,175.60
3200	229.0834	733,066.80
3250	744.4770	2,419,550.25
3300	21753.89	
3311.25	—	
3350	1804.559	
3400	338.9060	1,152,280.40
3600	30.1895	108,662.20
3800	9.9515	37,815.70
4000	4.7410	18,964.00
4200	2.6978	11,330.76
4400	1.7053	7,503.32
4600	1.1565	5,319.90
4800	0.8243	3,956.64
5000	0.7885	3,942.50
5200	0.4653	2,419.56
5400	0.3631	1,960.74
5600	0.2889	1,617.84
5800	0.2338	1,356.04
6000	0.1918	1,150.80
8000	0.0427	341.60
10,000	0.01515	151.50

As shown in the above table, resonance frequency distributes over 3300 ~ 3700 Hz, but it is considered that resonance frequency will distribute over 1000 ~ 1000 Hz if a little effect around  $\tau = 1$  is obtained.

$a_0$  is the amplitude at resonance. If it is "1", the energy conversion ratio for 1 cycle at  $a = \tau \times 1$  is in proportion to  $a^2$ .

$$\begin{aligned} \Delta W &= \pi \epsilon K a^2 f \\ &= Q a^2 f \end{aligned} \quad \dots\dots\dots(10)$$

where  
 $\epsilon$  : loss coefficient  
 $K$  : spring constant

Where  $Q = \pi \epsilon K$  Let  $Q \cong 1$ , then the following table is obtained.

**Effective Use of Helmholtz's Theory**

Figure 3-29 shows resonance characteristic for one hole. By changing dimensions of cavity, an ideal characteristic is obtained.

The resonance frequency of n-1 curve is as follows.

for  $V_1 \dots\dots\dots V_n$

$$f_1 = \frac{v}{2\pi} \sqrt{\frac{a}{V_1(\ell + 0.8d)}}$$

↓

$$f_n = \frac{v}{2\pi} \sqrt{\frac{a}{V_n(\ell + 0.8d)}}$$

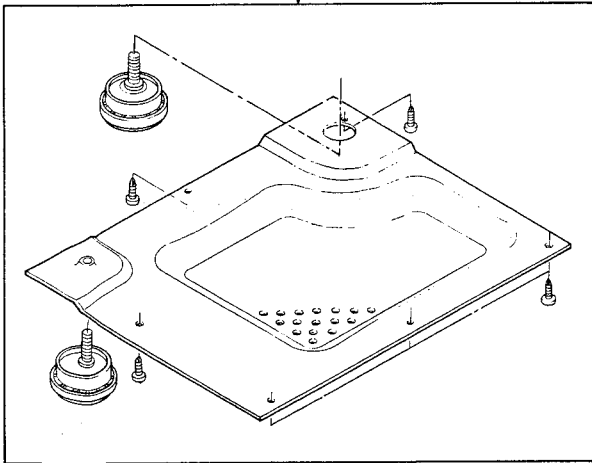
$f_n$  of 500 Hz ~ 15000 Hz is desirable in this case.

## DISASSEMBLY FOR REPAIR



\* Pull the button upward

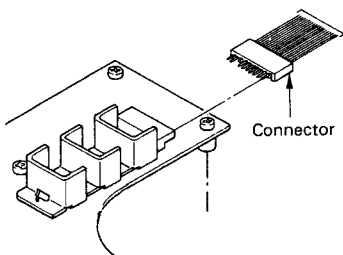
### BOTTOM PLATE



**Note:** When removing bottom plate, should remove the left-back insulator.

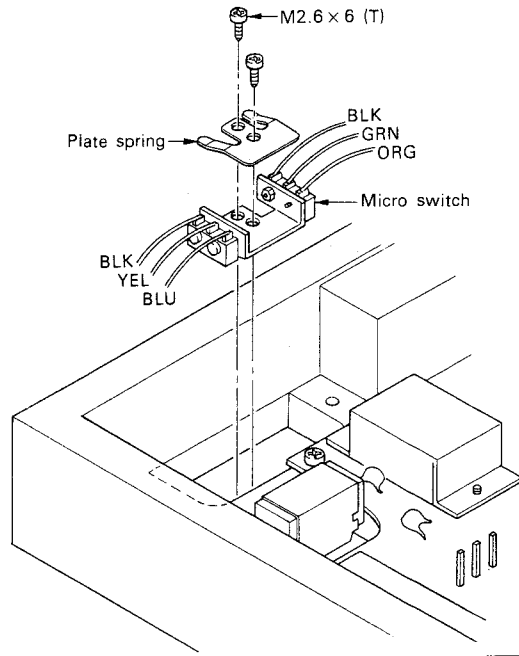
### MOTOR

When removing motor, pull out the connector from control PC board ass'y and unscrew the screw fixing motor to turntable case from top side.



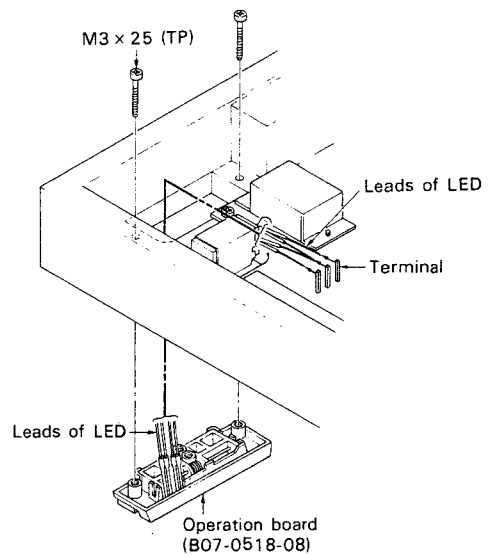
### MICRO SWITCH

When removing micro switch, unscrew the screw fixing switch mounting hardware to operation base and the screw fixing micro switch to switch mounting hardware.



### OPERATION BASE

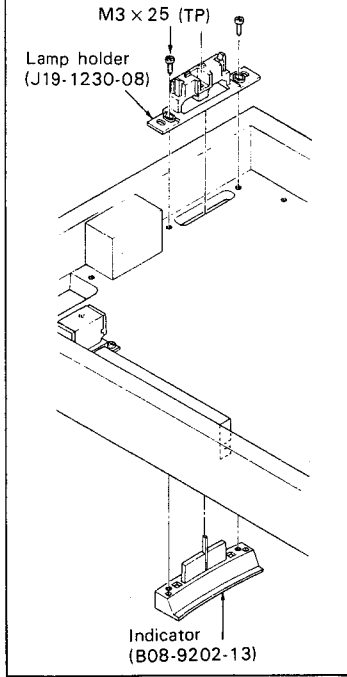
When removing operation base, unsolder leads of LED and unscrew the screw fixing it to turntable case.



# DISASSEMBLY FOR REPAIR

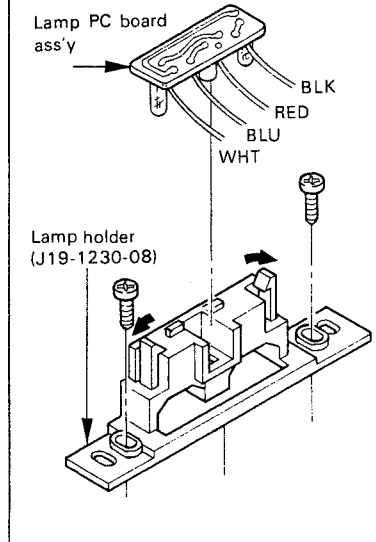
## INDICATOR

When removing indicator, unscrew the fixing screw.



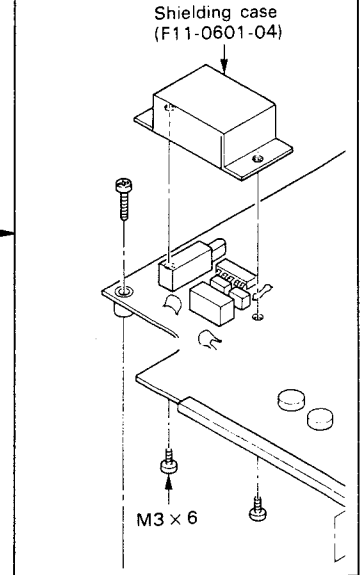
## LAMP PC BOARD

When replacing lamp PC board, extend the hook of lamp holder.



## SHIELDING CASE

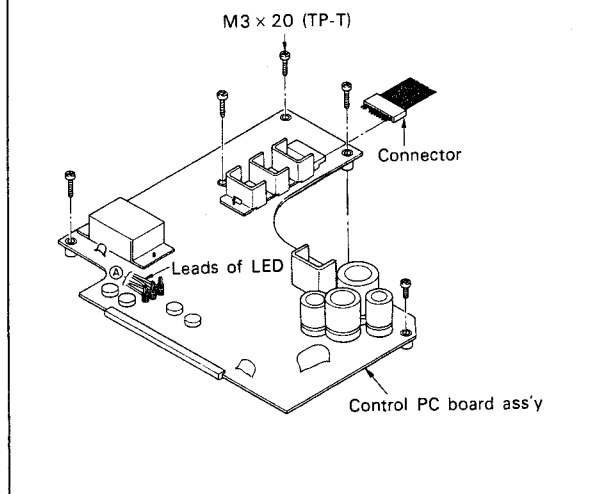
When removing the shielding case, unscrew the screw fixing it.



**Note:** Should not remove the shielding case without necessity. As IC in the shielding case is faulty by static electricity, use IC short tool when replacing it with new one.

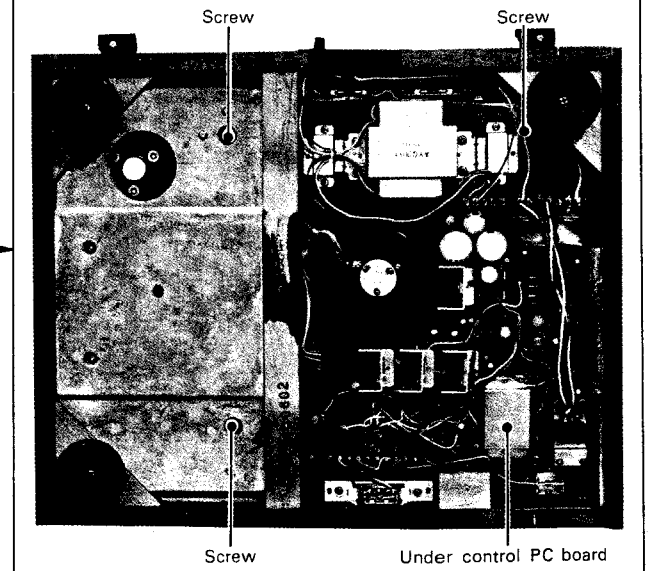
## CONTROL PC BOARD

When removing control PC board ass'y, first pull out the connector and unsolder lead connected to PC board, next unscrew the screw fixing PC board.



## TURNTABLE RING

When removing the turntable ring, unscrew the screw fixing it to turntable case from bottom side.



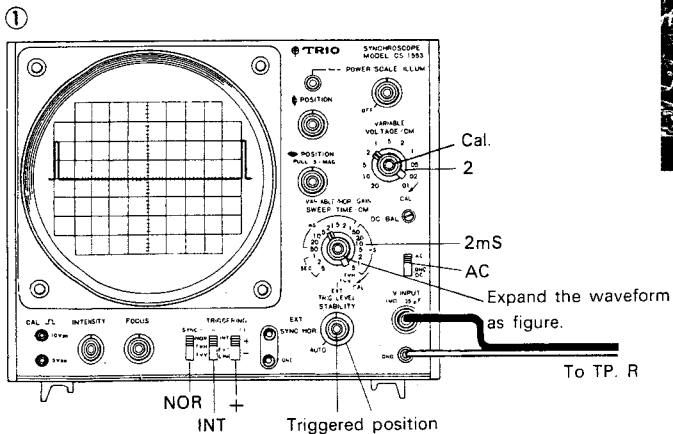
## ADJUSTMENT

### Before Adjustment

1. Motor should be loaded with turntable platter and turntable sheet.
2. Turn the trimming potentiometer VR1 and 2 on the control PC board ass'y to full counterclockwise.
3. Locate the turntable on the even position.
4. 33-1/3 rpm should be adjusted at first.
5. Connection cable to oscilloscope should be used probe cable.

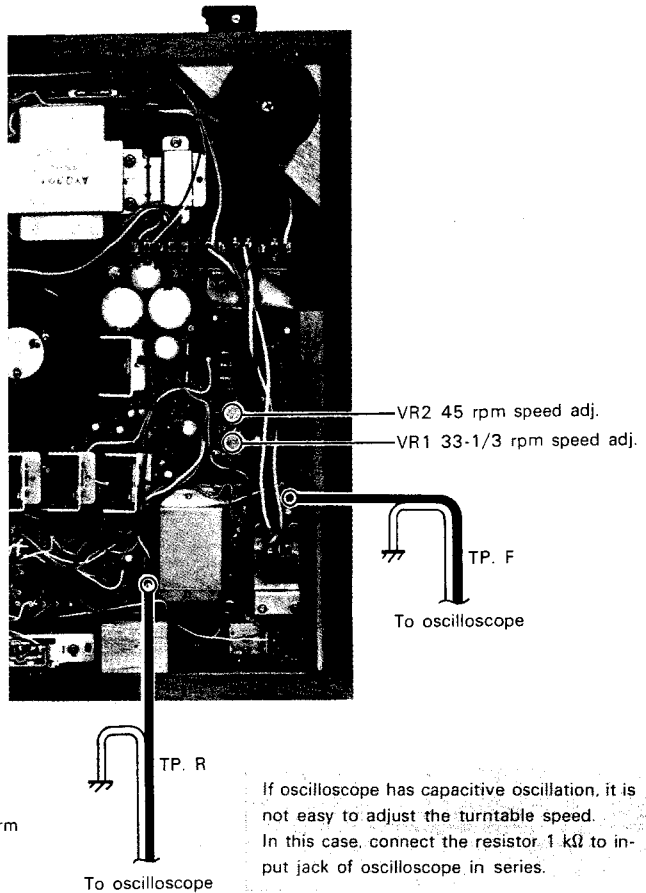
### Adjustment (with Oscilloscope)

1. Connect the oscilloscope to TP. R on the PC board.
2. Push the POWER switch and set the waveform as the following figure.

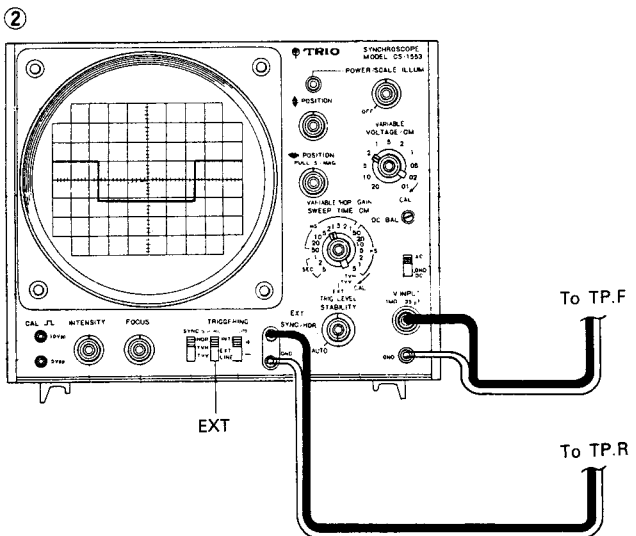


Waveform should be set 20mS period when 33-1/3 rpm.

3. Connect the output of TP. R to EXT input on the oscilloscope. (Don't touch the knobs.)
4. Connect the output of TP. F to V input on the oscilloscope.
5. Set the speed selector indicator to 33-1/3 rpm and push the play button.
6. Turn the trimming potentiometer VR1 so that the waveform of TP. F stops at the symmetric position of oscilloscope's center. When the waveform stops at corrective position, PLL indicator lights.
7. 45 rpm adjustment do the same way as that of 33-1/3 rpm. (VR2)



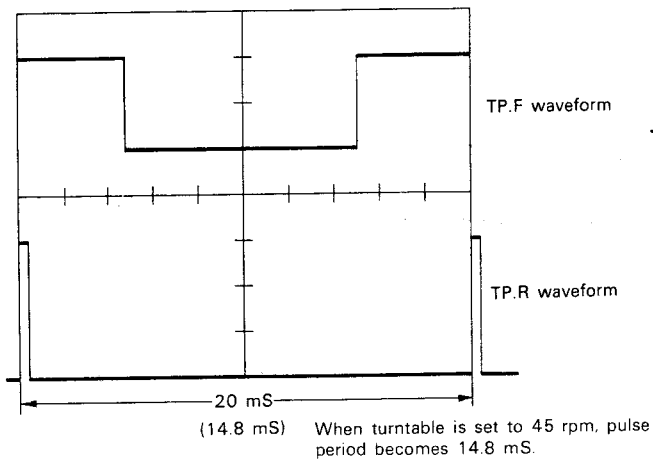
If oscilloscope has capacitive oscillation, it is not easy to adjust the turntable speed. In this case, connect the resistor 1 kΩ to input jack of oscilloscope in series.



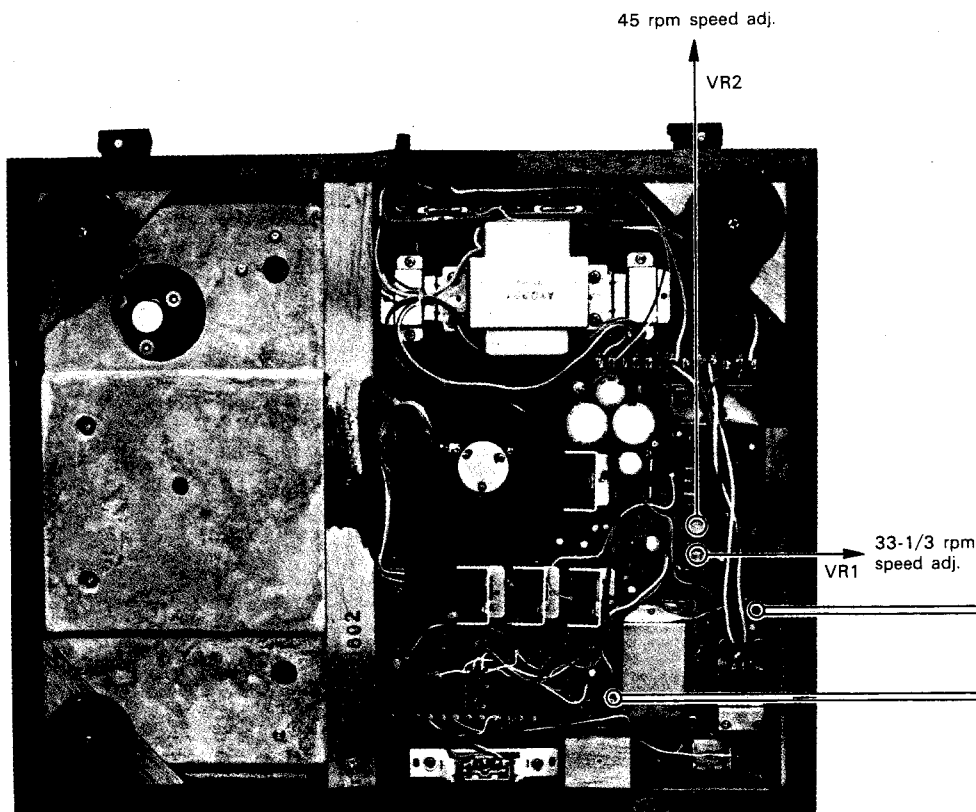
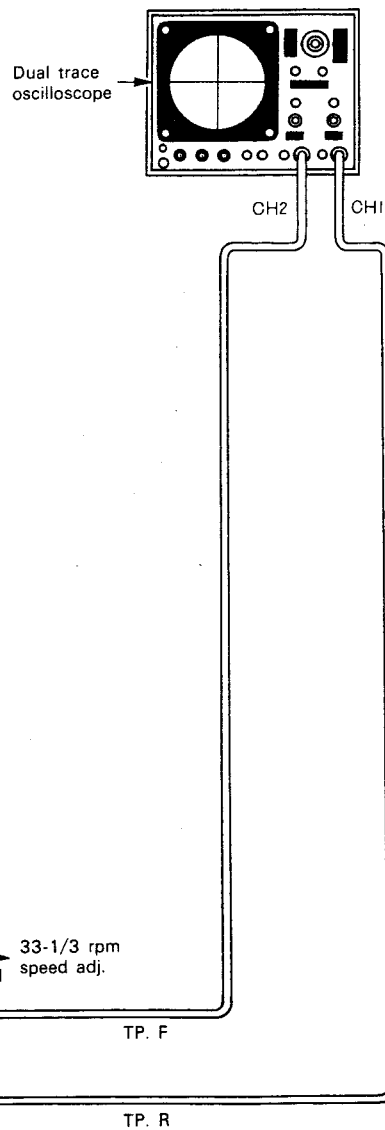
## ADJUSTMENT

### Adjustment (with dual trace oscilloscope)

1. Connect the output of TP. R and TP. F to input jack, respectively, as the following figure.
2. Expand the waveform of TP. R.
3. Stop the waveform of TP. F at the symmetric position of oscilloscope's center with the trimming potentiometers.



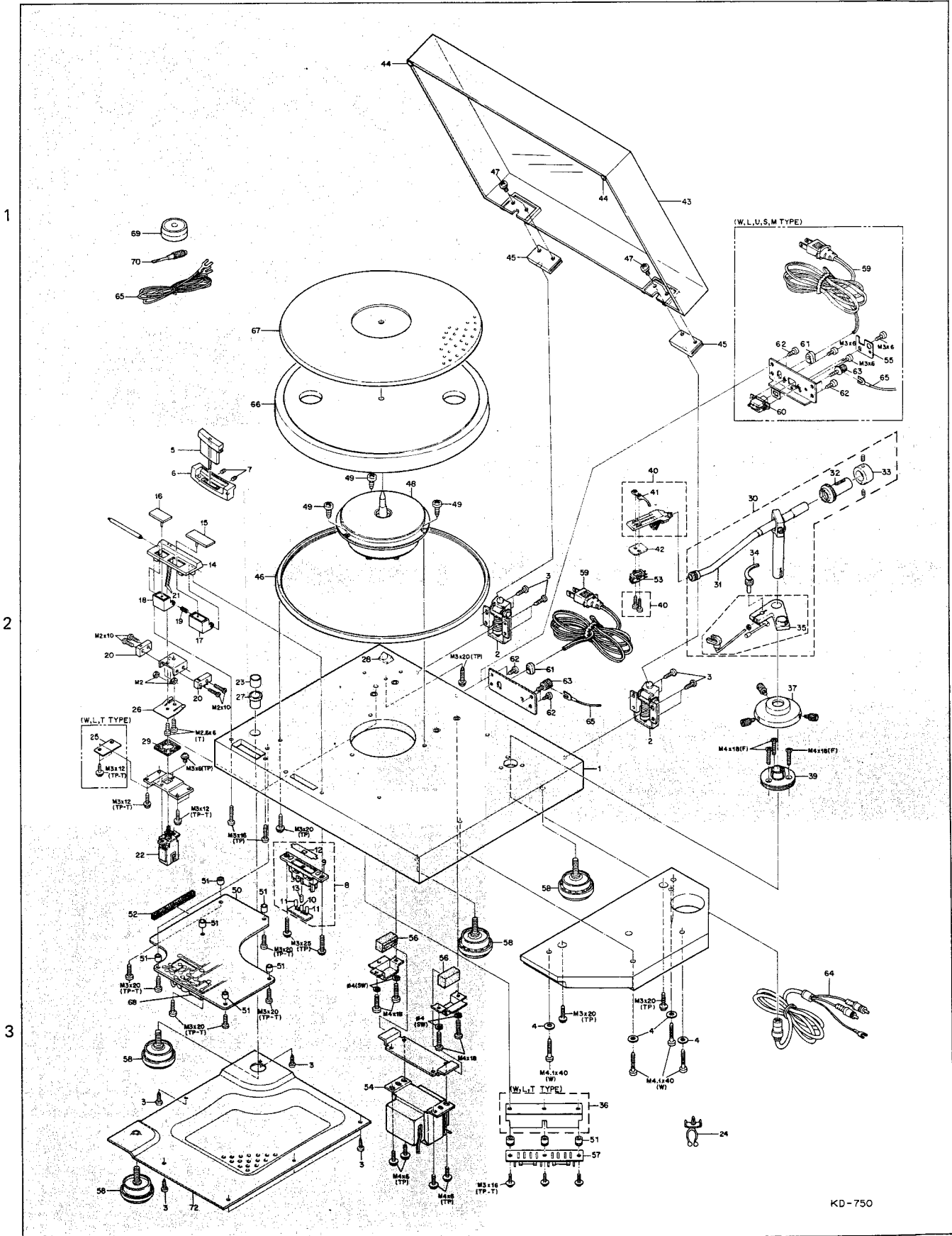
< Sample waveform with dual trace oscilloscope >



EXPLODED VIEW

A

B



**EXPLODED VIEW PARTS LIST**

Fig. No.	Parts No.	Description	Remarks
1	★	Turntable case	☆ 2B
2	J50-0304-05	Hinge (B)	2B
3	N09-0551-05	Tapping screw (M3 × 14)	2B, 3A
4	N19-0505-05	Flat washer (for M4)	3B
5	B08-9202-13	Indicator	☆ 2A
6	J19-1229-23	Indicator holder	☆ 2A
7	N73-2002-46	Set screw (M2 × 2)	☆ 2A
8	B38-0203-05	Lamp ass'y	☆ 3A
9	J19-1230-08	Lamp holder	☆ 3A
10	B30-0706-08	Lamp (A) (φ3. 5V, 0.06A)	☆ 3A
11	B30-0707-08	Lamp (B) (φ4.2. 5V, 0.06A)	☆ 3A
12	B11-0302-08	Reflector	☆ 3A
13	B09-0202-08	Collar cap	☆ 3A
14	B07-0518-18	Operation base	☆ 2A
15	K29-0636-18	Operation button (A)	☆ 2A
16	K29-0637-18	Operation button (B)	☆ 2A
17	D12-0207-18	Operation cam (A)	☆ 2A
18	D12-0208-18	Operation cam (B)	☆ 2A
19	G01-0648-18	Compression spring	☆ 2A
20	S50-1303-05	Micro switch	☆ 2A
21	B38-0202-15	LED ass'y	☆ 2A
22	★	Pushbutton switch	☆ 3A
23	K29-0638-04	Pushbutton	☆ 2A
24	J11-0303-05	Audio cord clasper	3B
25	★	Barrier (2)	☆ 2A
26	G01-0312-09	Plate spring	☆ 2B
27	B07-0519-04	Button base	☆ 2A
28	J09-0303-14	Shell stand	☆ 2A
29	G13-0420-24	Insulating rubber (C)	☆ 2A
30	J91-0108-05	Tonearm ass'y	☆ 2B
31	J91-0109-08	Tonearm	☆ 2B
32	D91-0110-08	Main weight (A)	☆ 2B
33	D91-0111-08	Main weight (B)	☆ 2B
34	J19-1231-18	lifter base	☆ 2B
35	J19-1232-08	Tonearm lifter ass'y	☆ 2B
36	★	Barrier (1)	☆ 3B
37	J19-1238-14	Tonearm base A ass'y	☆ 2B
38	—	—	—
39	J19-1235-24	Tonearm base (B)	☆ 2B
40	★	Headshell ass'y	☆ 2B
41	J92-0030-08	Finger	☆ 2B
42	J30-0403-05	Cartridge spacer	☆ 2B
43	A53-0213-02	Turntable cover	☆ 1B
44	G13-0405-04	Cushion	1A, 1B
45	J50-0303-05	Hinge (A)	1B
46	B07-0517-05	Turntable platter ring	☆ 2A
47	N08-0401-08	Dress screw	☆ 1B
48	T43-0012-05	Motor	☆ 2A
49	N09-0557-05	Tapping screw (M4 × 16)	2A
50	★	Control PC board ass'y	☆ 3A
51	J31-0415-04	PC board collar	☆ 3A, 3B
52	J30-0404-04	Spacer	☆ 3A
53	★	Cartridge	2B
54	★	Power transformer	☆ 3A
55	★	Switch stopper	1B
56	G13-0416-04	Insulating rubber	☆ 3A
57	X00-1310-00	Fuse PC board ass'y	☆ 3B
58	J02-0304-15	Insulator	3A, 3B

Fig. No.	Parts No.	Description	Remarks
59	★	Power cord	1B, 2B
60	★	Slide switch	1B
61	★	Cord bushing	1B, 2B
62	N09-0812-05	Tapping screw	1B, 2B
63	N08-0128-25	GND screw	1B, 2B
64	E30-1316-05	Audio cord	☆ 3B
65	E30-1301-05	GND lead	1A, 1B, 2B
66	D02-0021-05	Turntable platter	1A
67	★	Turntable sheet	☆ 1A
68	F11-0601-04	Shielding case	☆ 3A
69	W01-0304-04	EP adapter	☆ 1A
70	W01-0305-05	Small driver	☆ 1A
71	—	—	—
72	A40-0520 —	Bottom plate	☆ 3A
—	W01-0310-05	Silicone cloth	☆

When ordering the screw, nut and washer, refer to "screw nut manual issued by KENWOOD.

## DESTINATIONS' PARTS LIST

☆ : New Parts

Ref. No.	U.S.A. (K)	Canada (P)	PX (U)	Australia (X)	Europe (W)	Scandinavia (L)	England (T)	South Africa (S)	Other Area (M)	Description
1	A03-0537-11	A03-0537-11	A03-0537-11	A03-0537-11	A03-0537-11	A03-0537-11	A03-0545-11	A03-0537-11	A03-0537-11	Turntable case ☆
	B46-0061-00	B46-0055-20	B46-0062-10	B46-0064-00 ☆			B46-0060-00			Warranty card
	B50-2262-00	B50-2264-00	B50-2262-00	B50-2262-00	B50-2262-00	B50-2262-00	B50-2265-00	B50-2262-00	B50-2264-00	Warranty card
			B59-0018-00							Instruction manual ☆
										KENWOOD service stations' list.
55			D32-1080-24		D32-0080-24	D32-0080-24		D32-0080-24	D32-0080-24	Switch stopper (voltage selector)
59	E30-0181-05	E30-0181-05	E30-1317-05	E30-0185-05	E30-0459-05	E30-0459-05	E30-0587-05	E30-0587-05	E30-1317-05	Power cord
F1	F06-1026-05 ☆	F06-1026-05 ☆	F05-1023-05	F05-1023-05	F06-1021-05 ☆	F05-1021-05 ☆	F06-1021-05 ☆	F05-1023-05	F05-1023-05	Fuse (A)
2	F06-2024-05	F06-2024-05	F05-2023-05	F05-2023-05	F05-2029-05	F05-2029-05	F05-2029-05	F05-2023-05	F05-2023-05	Fuse (2A) ☆
36					F19-0511-04	F19-0511-04	F19-0511-04			Barrier (1) Fuse ☆
25					F19-0512-04	F19-0512-04	F19-0512-04			Barrier (2) Power switch ☆
67	G16-0318-05	G16-0310-05	G16-0310-05	G16-0310-05	G16-0310-05	G16-0310-05	G16-0310-05	G16-0310-05	G16-0310-05	Turntable sheet ☆
	H01-2272-04	H01-2274-04	H01-2272-04	H01-2274-04	H01-2274-04	H01-2274-04	H01-2273-04	H01-2274-04	H01-2274-04	Carton box ☆
61	J41-0034-05	J41-0034-05	J41-0034-05	J41-0024-15	J41-0017-05	J41-0017-05	J41-0017-05	J41-0017-05	J41-0034-05	Cord bushing
	J61-0050-15	J61-0050-15			J61-0050-15	J61-0050-15	J61-0050-15			Cord clamp
40	J92-0045-05	J92-0045-05	J92-0040-05	J92-0040-05	J92-0045-05	J92-0045-05	J92-0045-05	J92-0045-05	J92-0040-05	Head shell ass'y ☆
54	L01-6111-05	L01-6111-05	L01-6114-05	L01-6114-05	L01-6114-05	L01-6114-05	L01-6114-05	L01-6114-05	L01-6114-05	Power transformer ☆
			N09-0131-09	N09-0131-09				N09-0131-09	N09-0131-09	Cartridge mounting screw (M2.6 x 10)
60			S31-1006-05		S31-1006-05	S31-1006-05		S31-1006-05	S31-1006-05	Slide switch (power voltage)
22	S40-2302-15	S40-2302-15	S40-2302-15	S40-2302-15	S40-2075-04	S40-2075-04	S40-2075-05	S40-2302-15	S40-2302-15	Pushbutton switch (POWER) ☆
53			T21-0055-05	T21-0055-05					T21-0055-05	Cartridge (V-47)
50	X29-1110-01	X29-1110-03	X29-1110-02	X29-1110-02	X29-1110-04	X29-1110-04	X29-1110-04	X29-1110-02	X29-1110-02	Control PC board ass'y ☆

PARTS LIST (X29-1110-00~02)

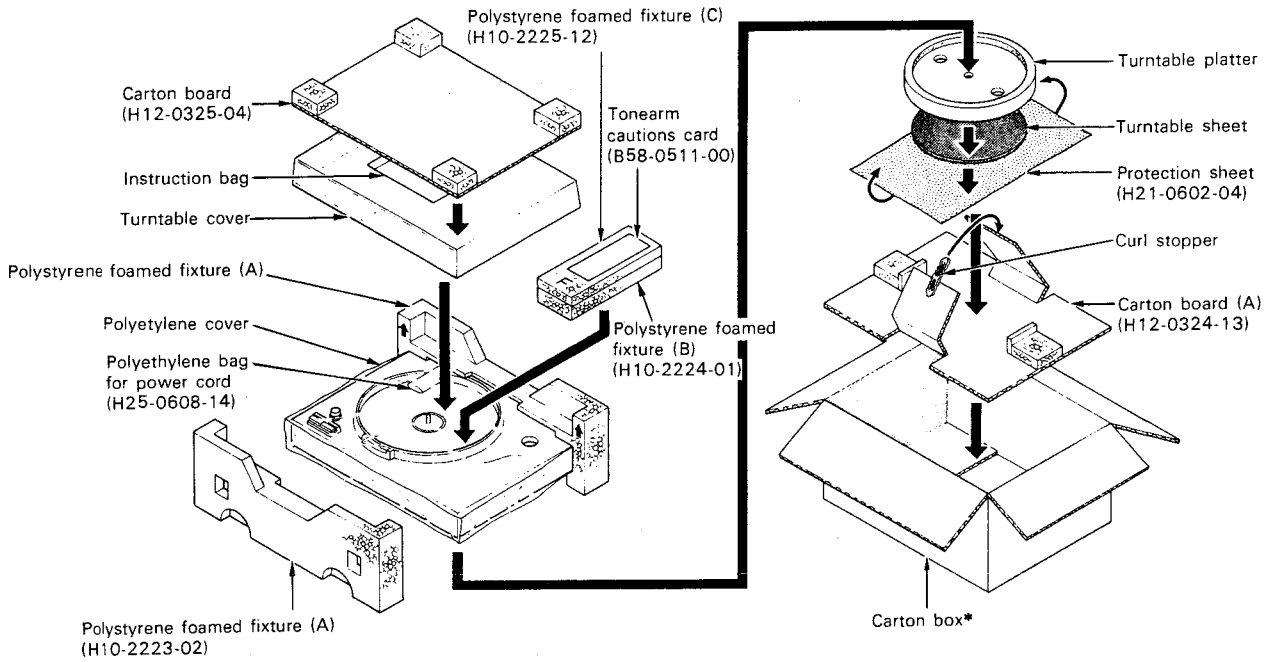
☆ : New Parts

Ref. No.	Parts No.	Description	Re- marks
<b>CAPACITOR</b>			
C101	CE04W1H100	Electrolytic 10 $\mu$ F 50WV	
C102,103	CE04W1C100	Electrolytic 10 $\mu$ F 16WV	
C104	CQ93M1H103K	Mylar 0.01 $\mu$ F $\pm$ 10%	
C105	CE04W1A101	Electrolytic 100 $\mu$ F 10WV	
C106	CE04W1C100	Electrolytic 10 $\mu$ F 16WV	
C108,109	CC45SL1H470J	Ceramic 47pF $\pm$ 5%	
C110	CS15E0J4R7K	Tantalum 4.7 $\mu$ F 6.3WV	
C111	C91-0311-05	Film 0.1 $\mu$ F $\pm$ 10%	
C112	C91-0312-05	Film 0.01 $\mu$ F $\pm$ 10%	
C113	C91-0211-05	Film 0.1 $\mu$ F $\pm$ 10%	
C114	CS15E0J4R7K	Tantalum 4.7 $\mu$ F 6.3WV	
C115	C91-0312-05	Film 0.01 $\mu$ F $\pm$ 10%	
C116,117	CQ93M1H223K	Mylar 0.022 $\mu$ F $\pm$ 10%	
C118	CQ93M1H102K	Mylar 0.001 $\mu$ F $\pm$ 10%	
C201	CS15E0J330K	Tantalum 33 $\mu$ F 6.3WV	
C202	CE04W1A101M	Electrolytic 100 $\mu$ F 10WV	
C203,204	CQ93M1H103K	Mylar 0.01 $\mu$ F $\pm$ 10%	
C205,206	CE04W1H3R3M	Electrolytic 3.3 $\mu$ F 50WV	
C207	CE04W1A101M	Electrolytic 100 $\mu$ F 10WV	
C208	CC45SL1H220J	Ceramic 22pF $\pm$ 5%	
C301	CE04W1V101	Electrolytic 100 $\mu$ F 35WV	
C302	CE04W1H010M	Electrolytic 1 $\mu$ F 50WV	
C303	CE04W1H3R3M	Electrolytic 3.3 $\mu$ F 50WV	
C304	CE04W1H010M	Electrolytic 1 $\mu$ F 50WV	
C305	CE04W1H3R3M	Electrolytic 3.3 $\mu$ F 50WV	
C306	CE04W1H010M	Electrolytic 1 $\mu$ F 50WV	
C307	CE04W1H3R3M	Electrolytic 3.3 $\mu$ F 50WV	
C308	CQ93M1H222K	Mylar 0.0022 $\mu$ F $\pm$ 10%	
C309	CQ93M1H103K	Mylar 0.01 $\mu$ F $\pm$ 10%	
C310	CE04W1H010M	Electrolytic 1 $\mu$ F 50WV	
C311	CQ93M1H393K	Mylar 0.039 $\mu$ F $\pm$ 10%	
C401,402	C90-0217-05	Electrolytic 3300 $\mu$ F 35WV	
C403	CE04W1V471	Electrolytic 470 $\mu$ F 35WV	
C404	CE04W1C222	Electrolytic 2200 $\mu$ F 16WV	
C405	CE04W1C100	Electrolytic 10 $\mu$ F 16WV	
C406,407	CK45D1H152M	Ceramic 0.0015 $\mu$ F $\pm$ 20%	
C408	CE04W1H010M	Electrolytic 1 $\mu$ F 50WV	
C409	CK45BC1H104M	Ceramic 0.1 $\mu$ F $\pm$ 20%	
C410	CE04W1H010M	Electrolytic 1 $\mu$ F 50WV	
C411,412	CK45BC1H104M	Ceramic 0.1 $\mu$ F $\pm$ 20%	
C413	CE04W1C100	Electrolytic 10 $\mu$ F 16WV	
C414	C91-0302-05	Ceramic 0.047 $\mu$ F (X29-1110-01)	
	R90-0402-05	C-R component 0.1 $\mu$ F $\pm$ 120 $\Omega$ (X29-1110-02)	
	C91-0024-05	Ceramic 0.047 $\mu$ F (X29-1110-03)	
C414,415	CK45E3D 103PMU	Ceramic 0.01 $\mu$ F 2kV (X29-1110-04)	
<b>RESISTOR</b>			
R108	RN14BK2E274F	Metal film 270k $\Omega$ $\pm$ 1% 1/4W	
R110	RN14BK2E184F	Metal film 180k $\Omega$ $\pm$ 1% 1/4W	
R119	RN14BK2E152F	Metal film 1.5k $\Omega$ $\pm$ 1% 1/4W	
R120	RN14BK2E472F	Metal film 4.7k $\Omega$ $\pm$ 1% 1/4W	
R123	RN14BK2E471F	Metal film 470 $\Omega$ $\pm$ 1% 1/4W	
R124	RN14BK2E241F	Metal film 240 $\Omega$ $\pm$ 1% 1/4W	
R125	RN14BK2E162F	Metal film 1.6k $\Omega$ $\pm$ 1% 1/4W	
R309	RS14AB3D2R2J	Metal film 2.2 $\Omega$ $\pm$ 5% 3W	

Ref. No.	Parts No.	Description	Re- marks
<b>SEMICONDUCTOR</b>			
Q1~3	V03-0270-05	Transistor 2SC945 (Q)	
Q4,5	V01-0733-10	Transistor 2SA733	
Q6	V03-0270-05	Transistor 2SC945 (Q)	
Q7~9	V01-0733-10	Transistor 2SA733	
Q10,11	V03-0270-05	Transistor 2SC945 (Q)	
Q12~14	V04-0079-05	Transistor 2SD586	
Q15	V03-0270-05	Transistor 2SC945 (Q)	
Q16	V04-0079-05	Transistor 2SD586	
Q17	V03-0270-05	Transistor 2SC945 (Q)	
Q18	V09-0058-05	FET 2SK30A (Y)	
D1~3	V11-0051-05	Diode 1N60	
D4,5	B38-0202-05	LED SG204D	
D6	V11-0051-05	Diode 1N60	
D7,8	V11-0076-05	Diode 1S1555 or V11-9978-05	
D9	V11-0051-05	Diode 1N60	
D10	V11-3100-30	Diode 1B2C1	☆
D11	V11-0320-05	Diode W04M7532	☆
D12	V11-3100-20	Diode 1B2Z1	
D13	V11-0076-05	Diode 1S1555 or V11-9978-05	
D14	V11-0254-05	Zener diode YZ-140	
D15	V11-0076-05	Diode 1S1555 or V11-9978-05	
IC1	V30-0260-10	IC $\mu$ PC1023H	
IC2	V30-0251-10	IC SN7473	
IC3,4	V30-0253-10	IC SN7400	
IC5	V30-0251-10	IC SN7473	
IC6,7	V30-0252-10	IC SN74121	
IC8	V30-0254-10	IC SN7402	
IC9	V30-0250-10	IC SM6415A	
IC10	V30-0256-10	IC CA324G	
IC11,12	V30-0261-10	IC SN7406	
IC13	V30-0257-10	IC TA7179P	
IC14	V30-0258-10	IC TA78005P	
IC15	V30-0253-10	IC SN7400	
IC16	V30-0263-10	IC SN16889P	
IC17	V30-0253-10	IC SN7400	
<b>COIL</b>			
T301	L32-0501-05	Oscillation coil	☆
X'tal	L77-0568-05	Crystal oscillator (6.0048MHz $\pm$ 20PPM)	☆
<b>POTENTIOMETER</b>			
VR1	R12-1302-05	Semi-fixed resistor 1.5k $\Omega$ (B) 33rpm	☆
VR2	R12-1301-05	Semi-fixed resistor 1k $\Omega$ (B) 45rpm	☆
<b>MISCELLANEOUS</b>			
-	E09-1161-05	Connector socket (11p)	☆
-	F01-0607-04	Heat sink A	☆
-	F01-0609-04	Heat sink B $\times$ 3	☆
-	F11-0601-04	Shielding case	☆
-	J13-0055-05	Fuse holder $\times$ 2	

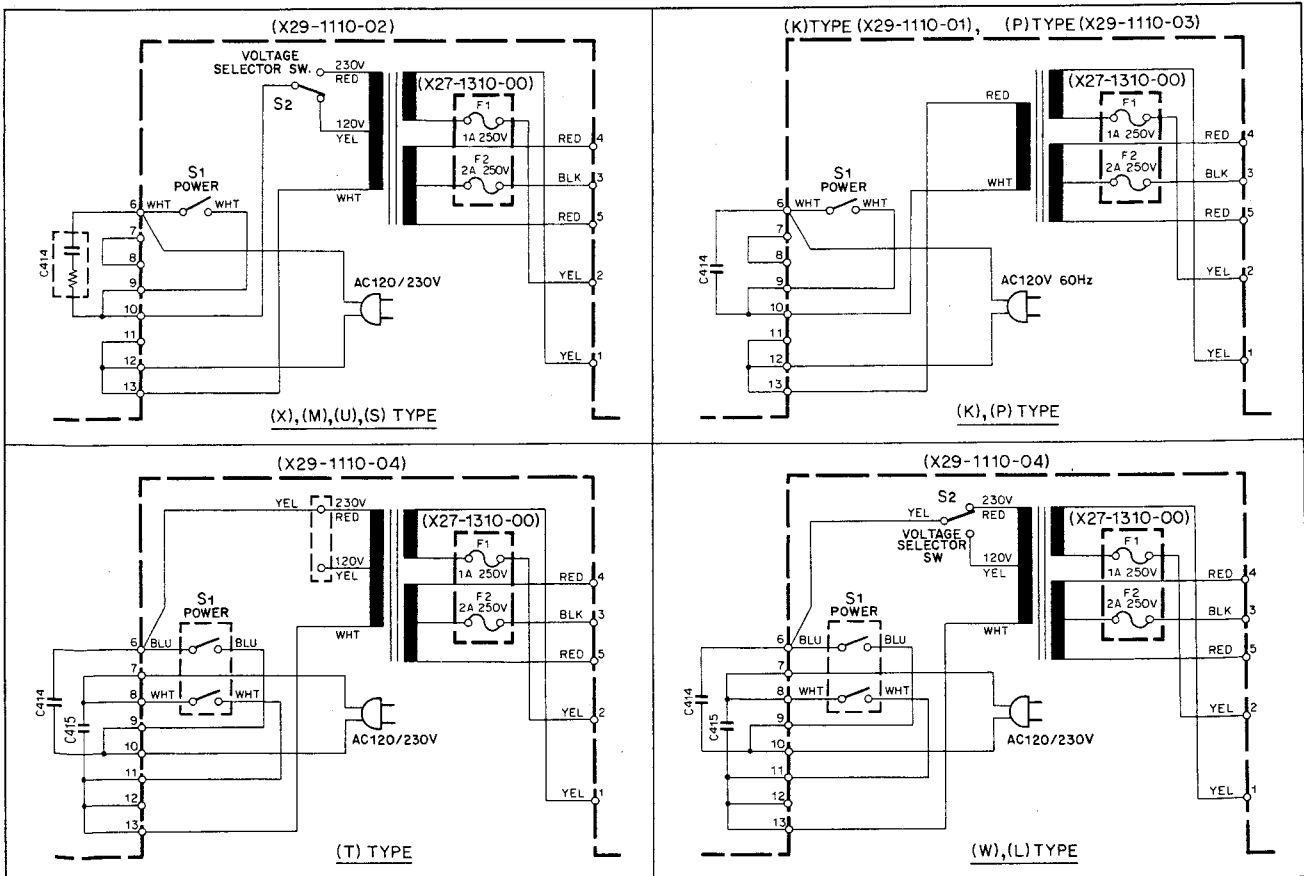
## PACKING/REVISED CIRCUIT

### PACKING

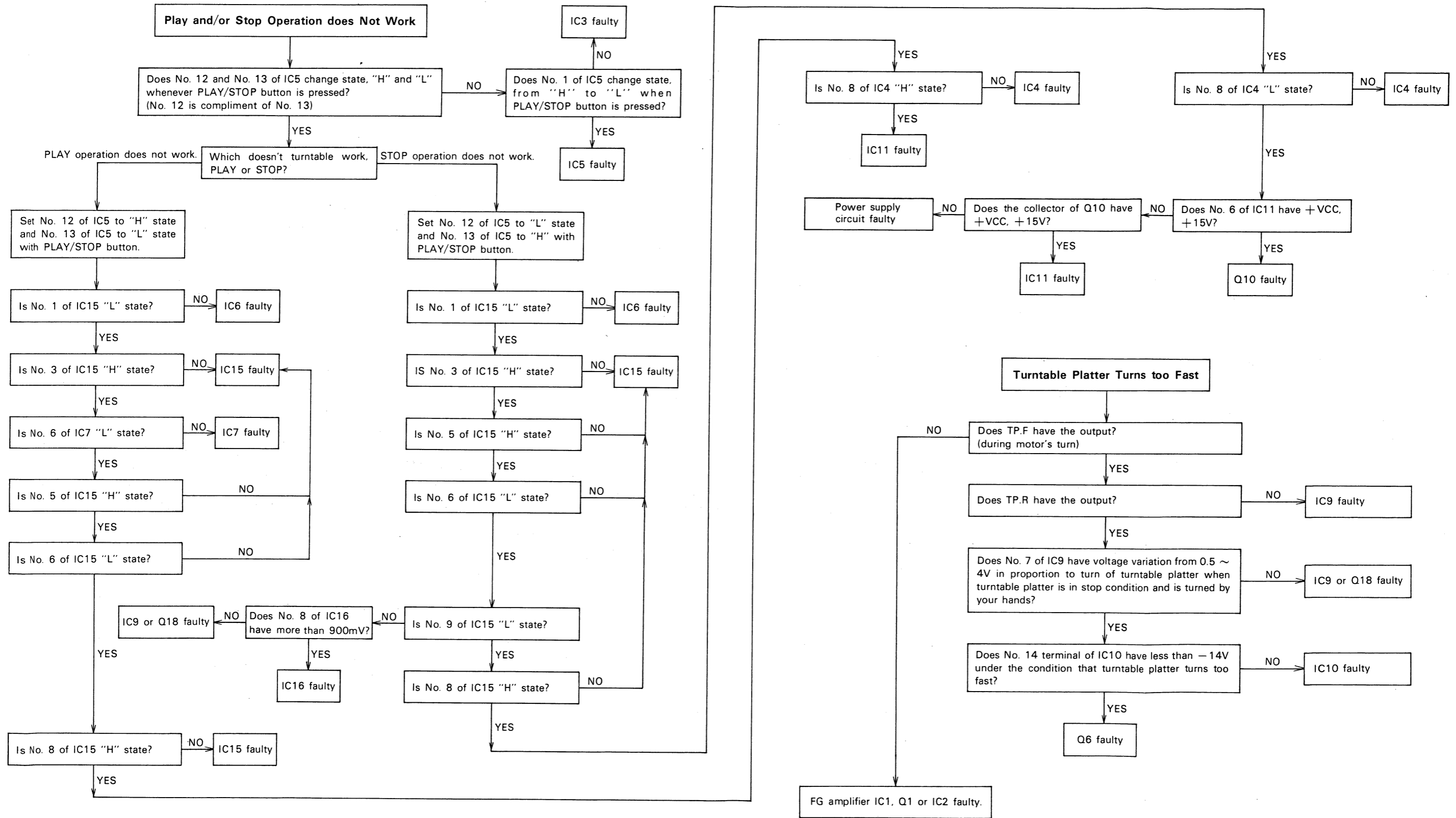


\* Refer to Destinations' Parts List.

### REVISED CIRCUIT



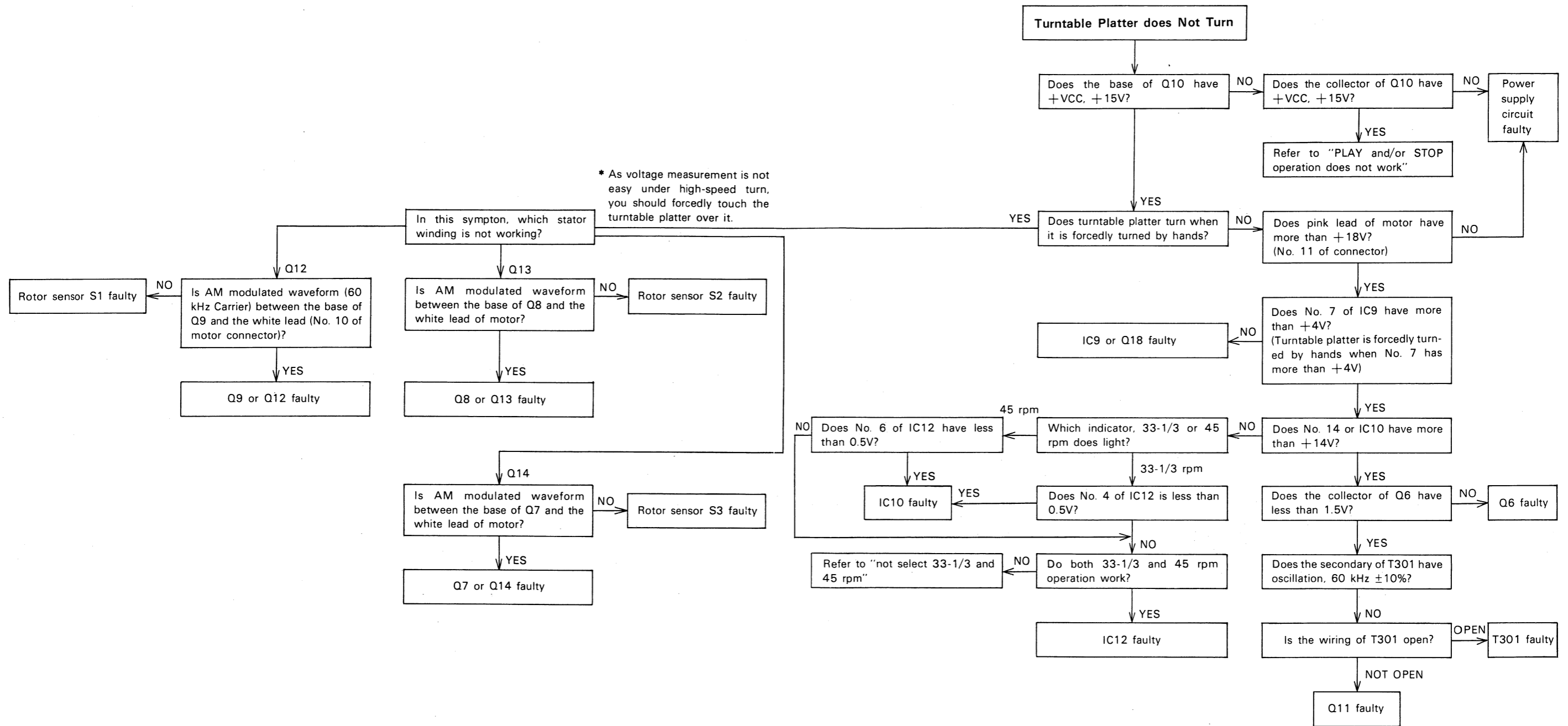
TROUBLESHOOTING



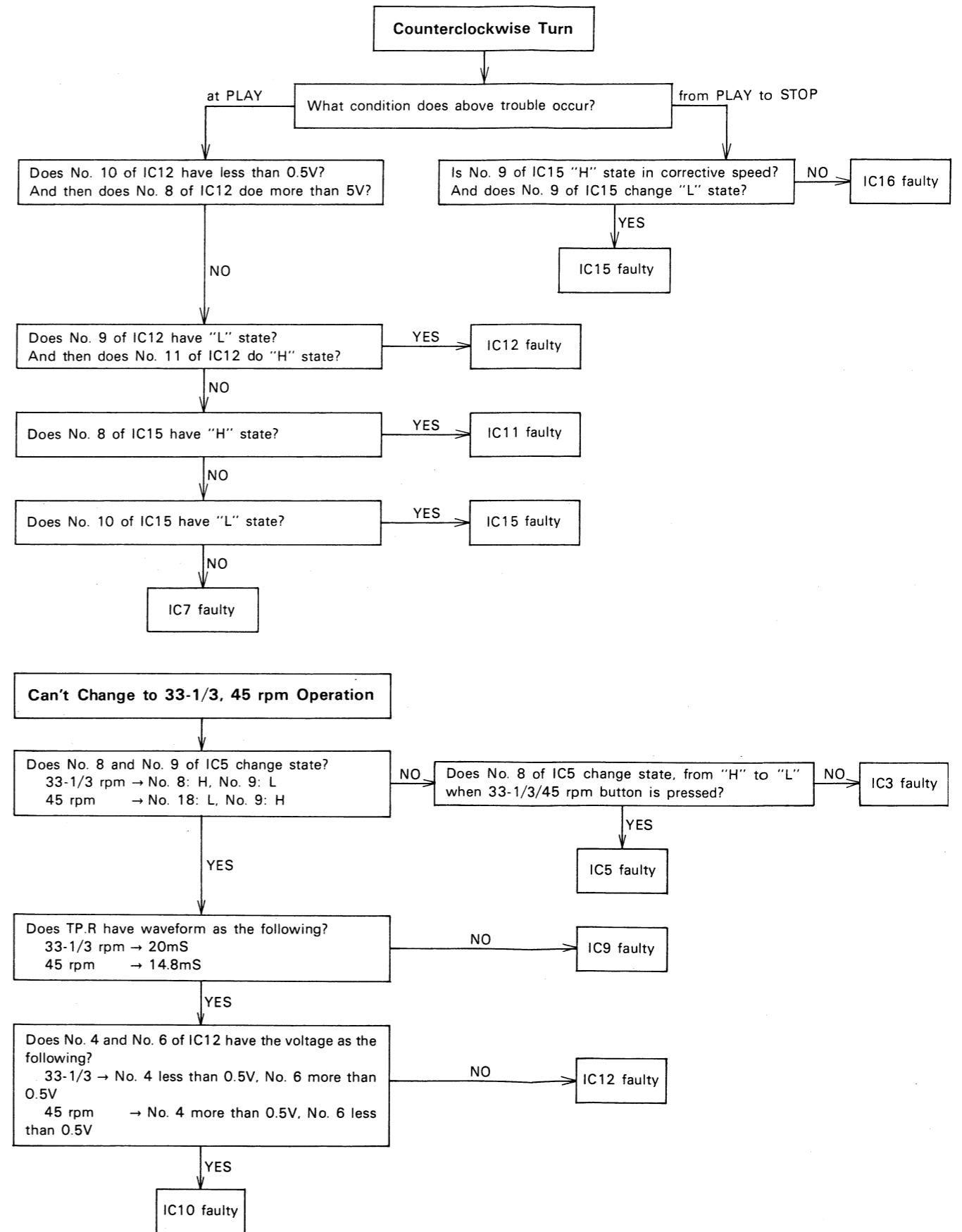
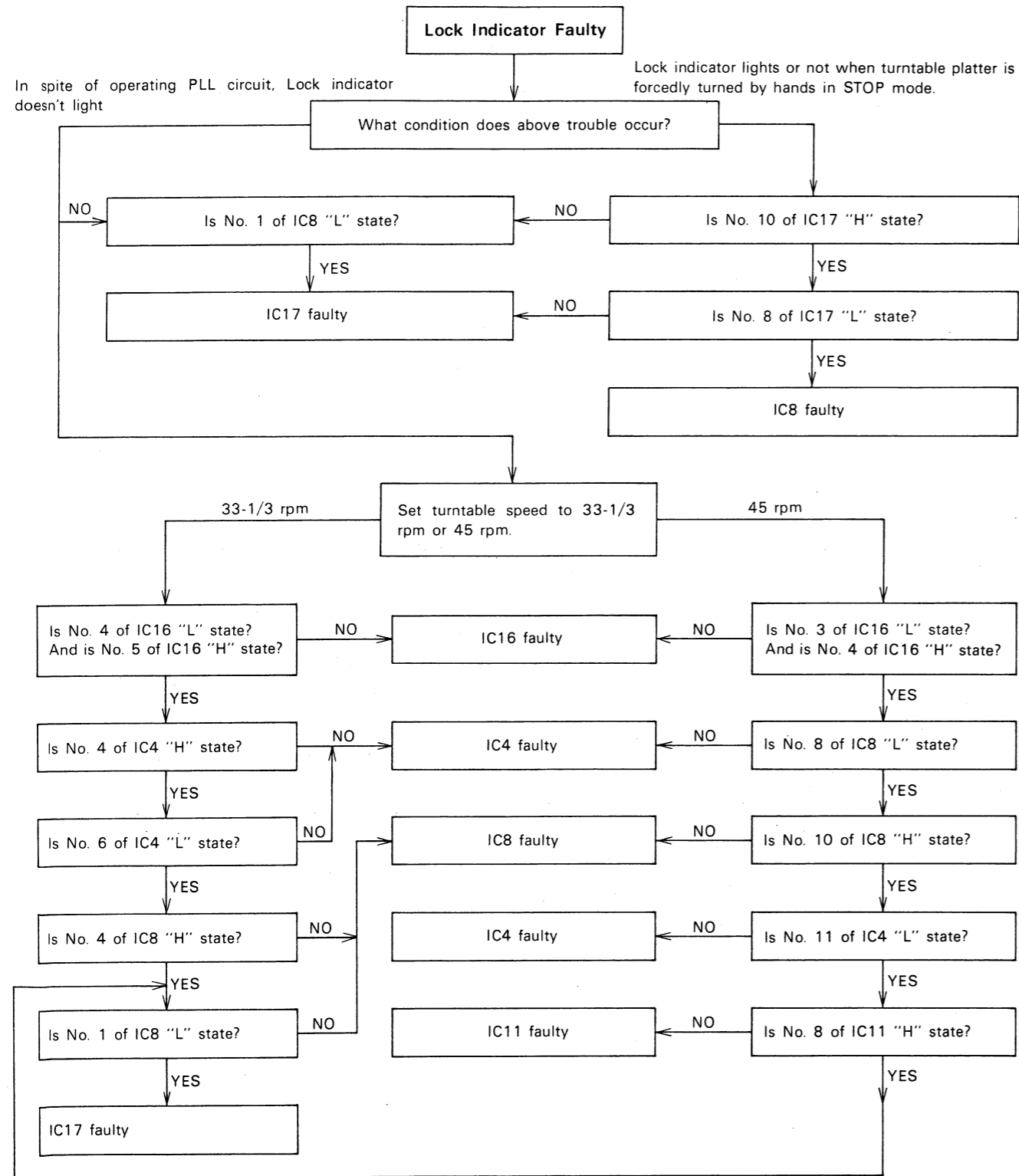
Note: The letters "H" and "L" in the note of troubleshooting mean; H for more than DC 2.4V, L for less than 0.4V in the logic circuit. When measuring voltage, be sure to use a VOM of more than 10kΩ/V.

# KD-750 KD-750

## TROUBLESHOOTING

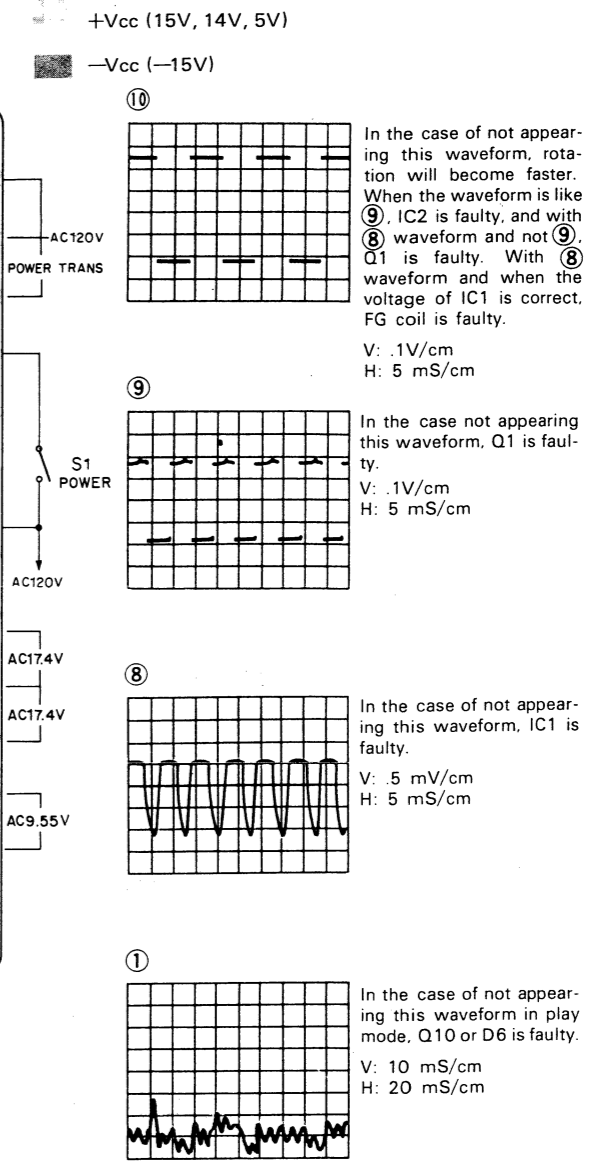
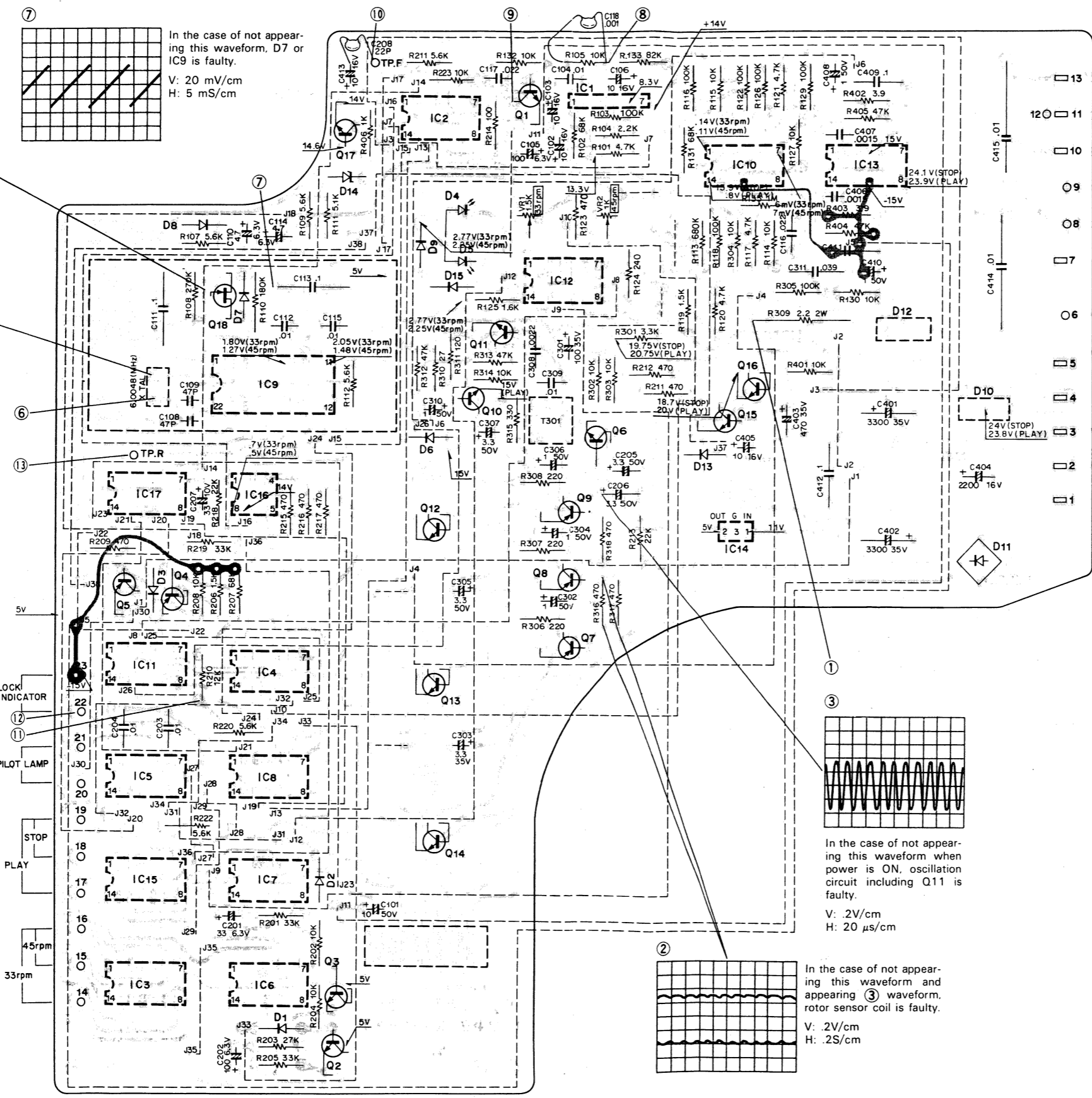
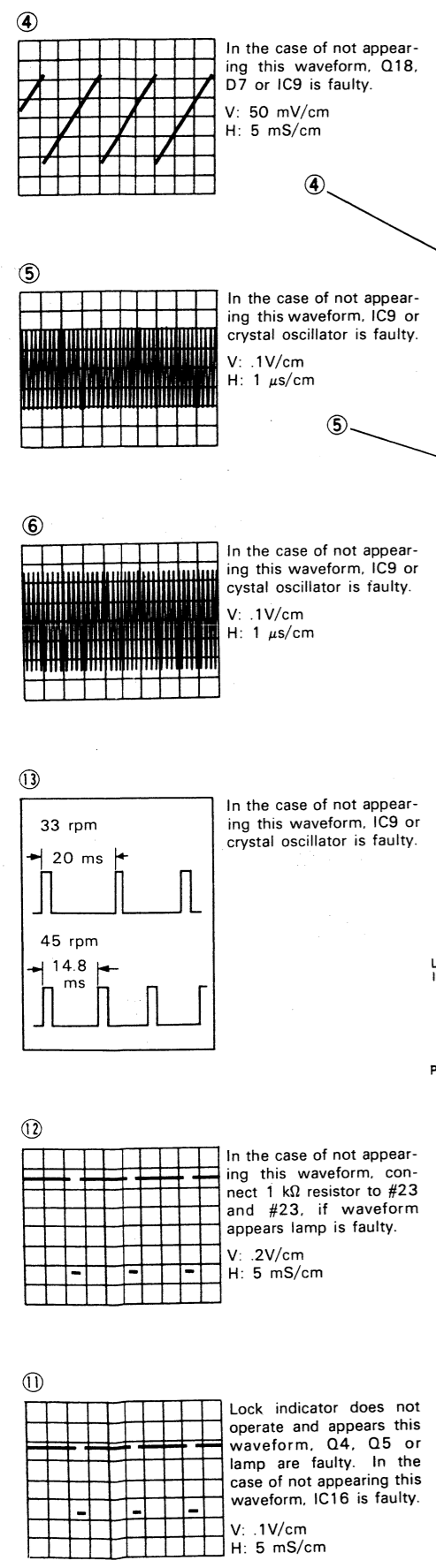


**TROUBLESHOOTING**



# KD-750 KD-750

## PC BOARD

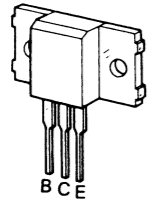
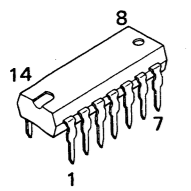


Q1~3,6,10,11,15,17:2SC945(Q), Q4,5,7~9:2SA733, Q12~14,16:2SD586, Q18:2SK30A(Y), D1~3,6,9:1N60, D4,5:SG204D, D7,8,13,15:1S1588  
 D10:1B2C1, D11:W04M7532, D12:1B2Z1, IC1:μPC1023H, IC2,5:SN7473, IC3,4,15,17:SN7400, IC6,7:SN74121, IC8:SN7402, IC9:SM6415A  
 IC10:CA324G, IC11,12:SN7406, IC13:TA7179P, IC14:TA78005P, IC16:SN16889, D14:YZ-140

**SCHEMATIC DIAGRAM**

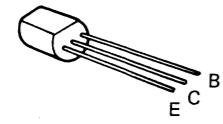
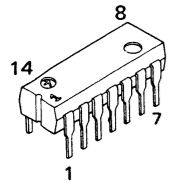
SN7400 SN7473  
SN7402 SN74121  
SN7406

2SD586



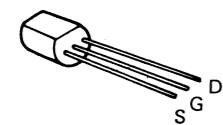
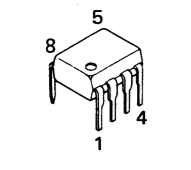
CA324G

2SA733  
2SC945



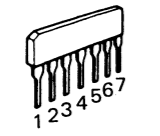
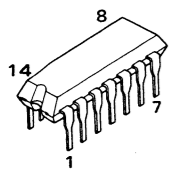
SN16889P

2SK30A



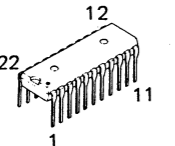
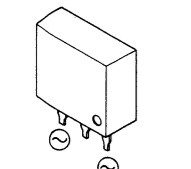
TA7179P

μPC1023H



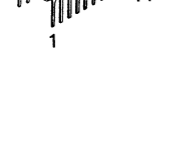
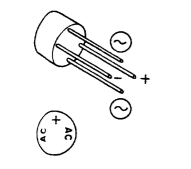
IB2C1 (Cathode is common)  
IB2Z1 (Anode is common)

SM6415A



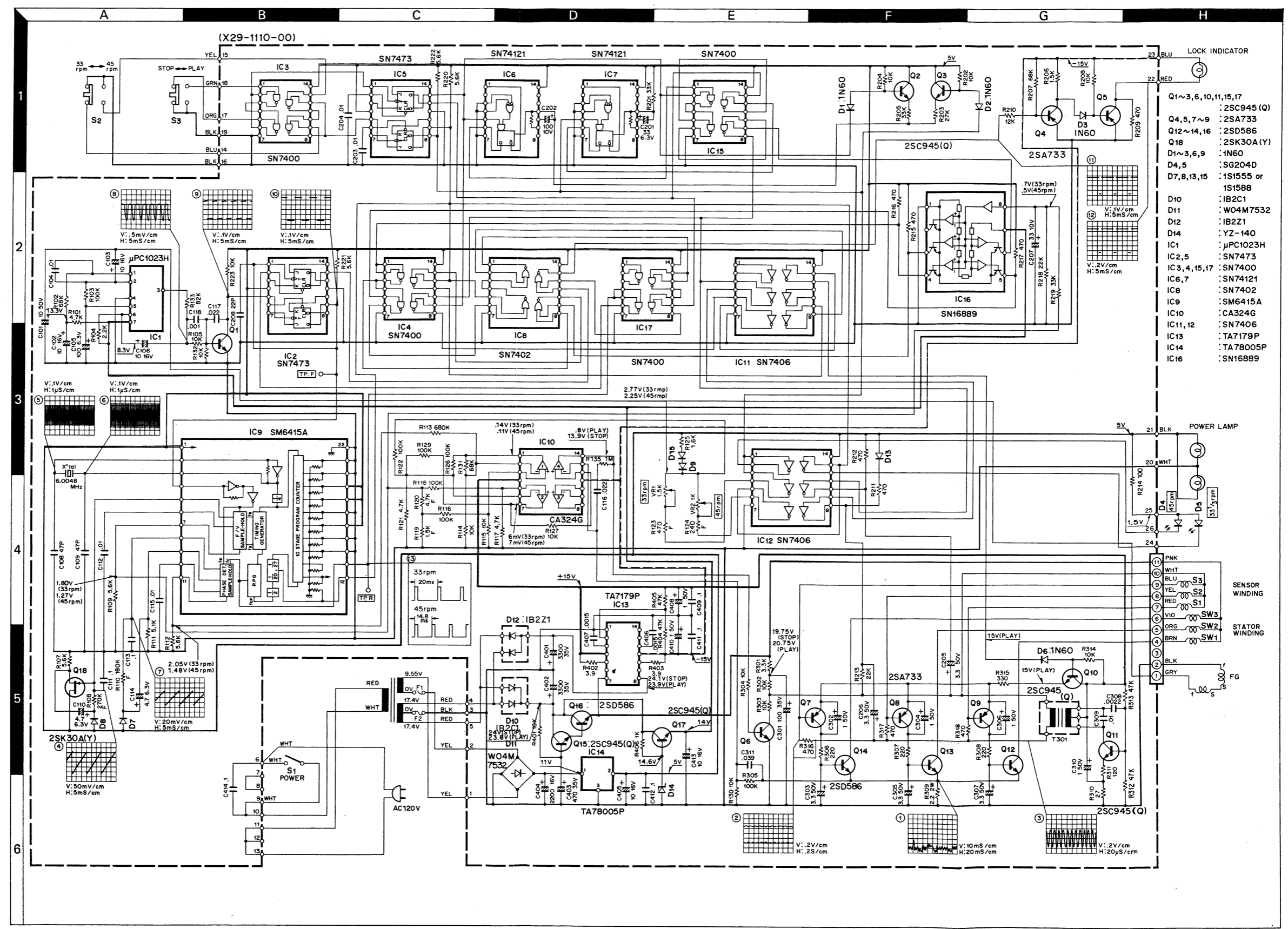
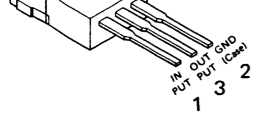
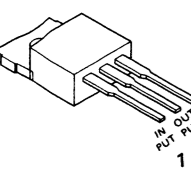
W04M7532

2SK30A(Y)



TA78005P

SM6415A



- LOCK INDICATOR
- Q1~3, 6, 10, 11, 15, 17 : 2SC945 (Q)
- Q4, 5, 7~9 : 2SA733
- Q12~14, 16 : 2SD586
- Q18 : 2SK30A (Y)
- D1~3, 6, 9 : 1N60
- D4, 5 : SG204D
- D7, 8, 13, 15 : 1S1555 or 1S1588
- D10 : IB2C1
- D11 : W04M7532
- D12 : IB2Z1
- D14 : YZ-140
- IC1 : μPC1023H
- IC2, 5 : SN7473
- IC3, 4, 15, 17 : SN7400
- IC6, 7 : SN74121
- IC8 : SN7402
- IC9 : SM6415A
- IC10 : CA324G
- IC11, 12 : SN7406
- IC13 : TA7179P
- IC14 : TA78005P
- IC16 : SN16889

REVISED circuit is drawn on page 46.

\* Probe of 10:1 is used in observing waveforms.  
\* DC voltages indicated here are measured with 20 kΩ/V meter.

# KD-750

## SPECIFICATIONS

### MOTOR & TURNTABLE

Drive System	Quartz PLL direct drive system
Motor	20 pole, 30 slot brushless D.C. servo motor (Starting torque 1.5 kg.cm)
Turntable Platter	33 cm (13 inch) diameter, aluminum alloy die-cast Weight: 2.6 kg (5.7 lbs.) Moment of inertia: 550 kg.cm <sup>2</sup>
Speeds	2 speeds, 33-1/3 and 45 rpm.
Wow & Flutter	Less than 0.022% (WRMS)
Rumble	DIN weighted better than -74 dB DIN unweighted better than -55 dB
Load Fluctuation	0% (within 120 g of tracking force)
Transient Load Fluctuation	Less than 0.0003% (at 33-1/3 rpm., 400 Hz, 20 g.cm load ) Less than 0.00015% (at 33-1/3 rpm., 1,000 kHz, 20 g.cm load)
Starting Time	Within 1.8 sec.
Platter Speed Deviation	Less than 0.002%
Time Drift	Less than 0.0002%/h
Temperature Drift	Less than 0.00002%/C°

### TO NEARM

Type	Static-balanced type, S-shaped pipe arm, EIA plug-in connector
Effective Tonearm Length	245 mm (9-5/8 inch)
Overhang	15 mm (9/16 inch)
Tracking Error	+1.5 to -1.0 degree
Tracking Force Variable Range	0 to 3 grams (0.1 g step)
Usable Cartridge Weight	4 to 14 grams
Adjustable Height Range	Within 6 mm (1/4 inch)
Arm Base	Collet chuck type
Headshell	Magnesium alloy die-cast type Weight: 11 g

### CARTRIDGE

(U.S.A., Canada, Europe and U.K. model are not equipped with the DM-11 cartridge)

Furnished Cartridge	DM-11
Stylus	N-11
Frequency Response	20 Hz to 20,000 Hz
Output Voltage	3.5 mV (1,000 Hz, 5 cm/sec.)
Optimum Tracking Force	2.0 ± 0.3 grams
Load Impedance	50 kohms
Channel Separation	Better than 27 dB (1,000 Hz)
Replacement Stylus	N-11

### MISCELLANEOUS

Power Requirement	AC 120V, 60 Hz: U.S.A., Canada model AC 240V, 50 Hz: U.K. Australia model AC 120V/220V (switchable) 50/60 Hz: Others
Power Consumption	35.0 watts
Dimensions	W 490 mm (19-5/16") H 165 mm (6-1/2") D 423 mm (16-5/8")
Weight	17.5 kg (38.6 lbs.)

### SUPPLIED ACCESSORIES:

Low capacitance phono cables with gold plated terminal, EP adaptor with overhang gauge, screw driver, silicon cloth, ground wire

### CABINET

Material	Particle board laminated with piano-finished kingrose veneer and a anti-resonance compression base (ARCB) are combined in the construction of cabinet.
Cabinet Ass'y Weight	7.5 kg (16.5 lbs.)
ARCB Weight	3.5 kg (7.7 lbs.)

### ADDITIONAL FEATURES:

Illuminated quartz lock and power indicator  
Electric-controlled brake  
Arm-height adjuster  
Collet chuck arm base  
Anti-skating device  
Viscous-damped cueing device  
LED speed indicator  
Dual suspension and adjustable insulator  
Free-stop action acrylic dust cover (Weight 1.2 kg)  
Tracking force direct readout counter  
Headshell stand

Note: Kenwood follows a policy of continuous advancements in development. For this reason specifications may be changed without notice.

A product of  
**TRIO-KENWOOD CORPORATION**  
6-17, 3-chome, Aobadai, Meguro-ku, Tokyo 153, Japan

**KENWOOD ELECTRONICS, INC.**  
1315 E. Watsoncenter Rd, Carson, California 90745  
75 Seaview Drive, Secaucus, New Jersey 07094, U.S.A.  
**TRIO-KENWOOD ELECTRONICS, N.V.**  
Leuvensesteenweg 184 B-1930 Zaventem, Belgium  
**TRIO-KENWOOD ELECTRONICS GmbH**  
Rudolf-Braas-Str. 20, 6056 Heusenstamm, West Germany  
**TRIO-KENWOOD FRANCE S.A.**  
5, Boulevard Ney, 75018 Paris, France  
**TRIO-KENWOOD (AUSTRALIA) PTY. LTD.**  
30 Whiting St., Artarmon, N.S.W. 2064, Australia  
**KENWOOD & LEE ELECTRONICS, LTD.**  
Room 501, Wang Kee Building, 5th Floor, 34-37, Connaught Road, Central, Hong Kong

© 1978-2 PRINTED IN JAPAN B51-0498-00 (G) 3.617