

Gérard Perrot
Héphaïstos Laboratories, Montrouge, France

**Presented at
the 100th Convention
1996 May 11–14
Copenhagen**



AES

This preprint has been reproduced from the author's advance manuscript, without editing, corrections or consideration by the Review Board. The AES takes no responsibility for the contents.

Additional preprints may be obtained by sending request and remittance to the Audio Engineering Society, 60 East 42nd St., New York, New York 10165-2520, USA.

All rights reserved. Reproduction of this preprint, or any portion thereof, is not permitted without direct permission from the Journal of the Audio Engineering Society.

AN AUDIO ENGINEERING SOCIETY PREPRINT

Measurement of a Neglected Circuit Characteristic

Gérard PERROT
Héphaïstos Laboratories
F-92120 MONTROUGE, FRANCE

Abstract

This paper is related to a new approach of audio circuit measurements. Present distortion measurements fail to tally with listening tests, and try to define effects of memoryless non-linear transfer functions. Unfortunately, audio circuits are not memoryless.

This paper presents a measurement set for circuit memory. First measurements seem to exhibit good correlation between this new distortion and listening tests.

1 Introduction

Measurement of distortion is fundamental for design and evaluation of audio circuits. Several techniques have been defined for distortion measurement and have been widely used for improvement of audio circuits. However, the evaluation of top quality circuits via listening tests does not tally with the figures given by these techniques, and more and more people prefer tube circuits in spite of their poor distortion figures.

There have been some attempts to define new, sharper measurements better correlated with subjective tests, but with little success. An explanation of this failure may be that these new measurements are based on the classical theoretical model of distortion, regardless of a possible misconception concerning distortion in audio circuits. Questioning the theoretical bases of audio circuit distortion is fruitful and leads to breaking new ground in audio circuit measurement.

2 Summarised theoretical analysis

2.1 Traditional theoretical analysis

Fig. 1 presents the classical theoretical model of an audio power amplifier. This model is the base for measuring amplifier distortion. It is made up of a perfect amplifier and two distortion generators : the linear distortion generator corresponds to the amplitude, phase, phase-slope and group delay modifications resulting from the band limitations of a real amplifier ; the non-linear distortion generator corresponds to the non-linear transfer characteristic of a real amplifier.

The aim of current distortion measurement is to characterise the distortion generators. Band limitation and non-linear transfer function are measured in order to fully characterise the circuit under test and to define its distortion for any audio signal. The characterisation of the distortion generators is made with sinusoidal signals.

This approach is rigorous and is valid as long as the model itself is valid. The validity of the distortion model is widely accepted even though this model does not take into account a known distortion phenomenon : Transient Intermodulation Distortion. The reason for this is probably that TID (as far as this concept is limited to slew-rate limitation) only affects poorly designed circuits and can easily be avoided. However, slew-rate limitation shows that linear and non-linear distortions can be combined in a more complex way than in the classical amplifier model.

Unfortunately, other phenomena combining linear and non-linear distortion occur in many audio amplifiers. Thus their non-linearity is not adequately analysed with sine waves and thus by classical distortion measurements. It is possible to exaggerate these phenomena and to design two simple circuits ^[1] exhibiting exactly the same classical distortion, measurement (band limitations, non-linear distortion figures and spectrum) but showing different distortions with many non-sinusoidal and audio signals. These circuits also have a very different sound quality. They prove that the classical measurements of a circuit are usually unable to define its sound quality.

This example highlights a basic limitation of classical measurements in that static measurements are only reliable for stable systems. Classical measurements rely on the implicit hypothesis that the distortion characteristics are immutable. If not, classical measurements fail to fully characterise circuit distortion and to define circuit behaviour with any signal.

2.2 New theoretical analysis

A thorough theoretical analysis of audio circuits reveals many possible

causes making characteristics unstable and, especially, variable according to the signal. These changes often have time constants inducing memory phenomena. There are many sources of memory in audio circuits :

- Memory occurs in components. The main source of memory in components is known as thermal feedback in transistors ; memory also affects resistors (self-heating), capacitors (dielectric absorption) and wiring (skin effect in cables).
- Memory also occurs in circuits and mainly results from combinations of non-linear transfer functions and band limitations (in power supplies and in feedback loops).
- Global memory is the combination of all these memory effects.

A new circuit model including memory (Fig. 2) can be proposed for distortion analysis. The linear distortion is produced not only by the band limitation effects, but also by the memorizing of the signal. The non-linear distortion is produced by a non-linear variable transfer function. Fig. 3 presents the basic possible variations of the transfer function (the distortion of the memorised signal might also be considered).

The new distortion model is more complex than the previous one and its characteristics are not easy to measure. Memory phenomena are ignored by measurements using static signals like steady-state sine waves (or the signals used for the attempts of new measurements).

3 New measurement set

3.1 Principle

Memory measurement in audio circuits is not easy : the related phenomena are generally of low amplitude and may be complex (with, for example, positive feedback). However, a first new measurement technique has been defined, which confirms the reality of memory in audio circuits and indicates the order of magnitude of this phenomenon.

The principle of this measurement consists of freezing the input signal at a fixed value and measuring the output drift which reveals the fleeting memory of the circuit under test. It can be done with digital audio circuits provided the DA converter is memoryless. Another method consists in switching the input to zero and to analyse the output drift. In that case, the effect of high frequency band limitations appears (the related time constants are short compared with usual memory phenomena). In both cases, the low frequency band limitations can affect output voltage and may mask memory (a low frequency pole is also a kind of memory).

3.2 Description

The measurement set uses an external generator whose signal is on-off modulated (Fig. 4). For these first measurements, the input signal was very simple (sinus, triangle or square) and a synchronised time base modulated it to a tone-burst ; however, this method is compatible with any input signal (including real audio signals).

The analysis of the output drift is not easy (drift is of few mV) for output signals of few volts. This was done via a blanked re-zeroing preamplifier (Fig. 5) and a digital oscilloscope providing an average display mode in a repetitive or slowly swept mode (in order to cancel noise and hum).

3.3 Encountered problems

The main difficulties arose from memory phenomena in the switch and in the preamplifier but, after a long set-up procedure including many component changes, the remaining drift of the measurement set was several orders of magnitude lower than the drift of the tested circuits.

For the circuits without a low frequency pole, it is possible to analyse the drift (and to evaluate the amplitude of the memory signal) for any point within the input signal. The memorised signal can thus be reconstituted. For circuits with a low frequency pole, this method allows sampling of memory only for some points of the input signal : at these points the low frequency pole induces no recovery after switching of the input signal. Digital processing of the output signal could make memory measurable in spite of low frequency poles.

4 First results

4.1 DC amplifier

Many measurements were made with an amplifier similar to the amplifier of J. Lohstroh and M. Otala [2]. Its schematic is rather clean for memory, and the drift (Fig. 6) results mainly from transistors thermal drifts. Its shape corresponds to a non-exponential function which has been simulated (Fig. 7). It induces a linear thermal memorisation of the signal.

The memorised signal is a "ghost" signal superimposed on the input signal. Its amplitude is about - 60 dBc. It is not noticeable with sine waves and its audibility is probably linked to its unusual amplitude/phase frequency relationship making it sound like a strange subliminal echo.

4.2 AC amplifiers

Measurements of sampled memory were made in the same condition (a tone-burst of a 60 Hz sinus signal at ± 6 V pk-pk on a 4Ω load) for 3 amplifiers using different technologies :

- a commercially available high quality transistor amplifier, with a THD of -86 dBc at the level of the test signal (Fig. 8)

- a triode tube amplifier designed by an audiophile, with a THD of -27 dBc at the level of the test signal (Fig. 9)

- a new transistor amplifier designed for low memory, with a THD of about -110 dBc at the level of the test signal (Fig. 10).

4.3 Correlation with listening tests

Several listening tests were made with the measured AC amplifiers in different conditions, with different listeners ; they gave the same results. They seem to show that the measured memory is better correlated with sound quality than the THD.

The tube amplifier, in spite of its poor distortion figure, was judged as giving a much more natural sound than the traditional transistor amplifier, completely in opposition to the traditional distortion measurement values.

The memory-free transistor amplifier, thanks to its unusual sound quality, was preferred to the tube amplifier even by tube fanatics involved in the listening tests. This result seems to invalidate an explanation for the preference for tube circuits : the hypothesis of distortion pleasant for the ear.

4.4 Other measurements

Other limited measurements concerning the impact of capacitor technology and feedback factors on memory amplitude seem to confirm some empirical statements of "golden ears" ; they have to be confirmed by further experimentation.

5 Conclusion

These limited first results of memory measurements in audio circuits prove that memory really occurs in audio circuits. They show that the proposed model for circuit distortion is closer to reality than the traditional model.

Even if the reason for the audibility of memory distortion is not yet clear,

the sound quality improvement resulting from a memory-free design shows that memory is audible. Low memory distortion is the probable reason for the good sound of tubes.

Much work still has to be done for measuring memory distortion and understanding its effects on audio signals ; however, memory distortion has to be considered when improving and measuring audio circuits.

[1] Héphaïstos, "Comprendre le son des tubes" (Understanding the sound of tubes), LED n° 136, Jan./Feb. 1996

[2] "An Audio Power Amplifier for Ultimate Quality Requirements", J. Lohstroh and M. Ojala, IEEE trans. on audio and electroacoustics, vol. AU-21, n° 6, Dec 1973

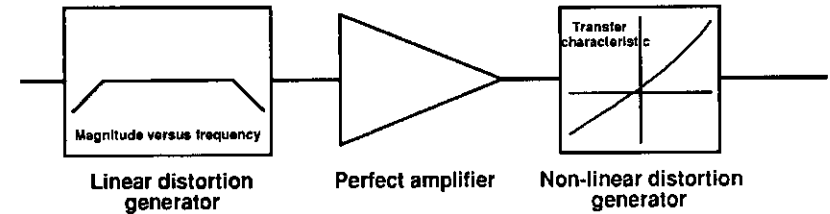

Figure 1 : The classical model of an audio amplifier

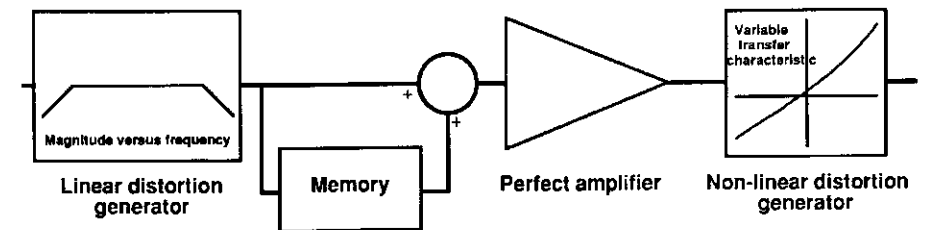

Figure 2 : The new model of an audio amplifier

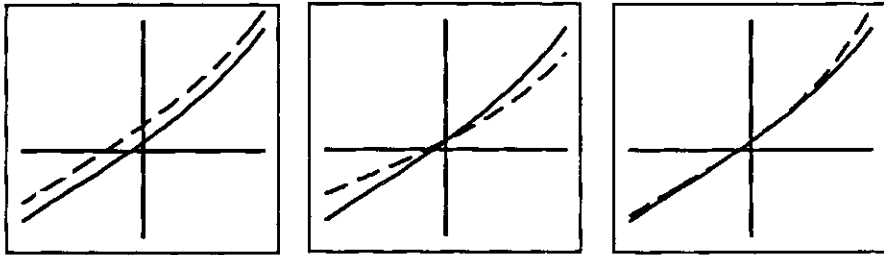

Figure 3 : The 3 basic variations of the transfer function : offset variation, gain variation and non-linearity variation .

NOTE : offset variations can be included in memory.

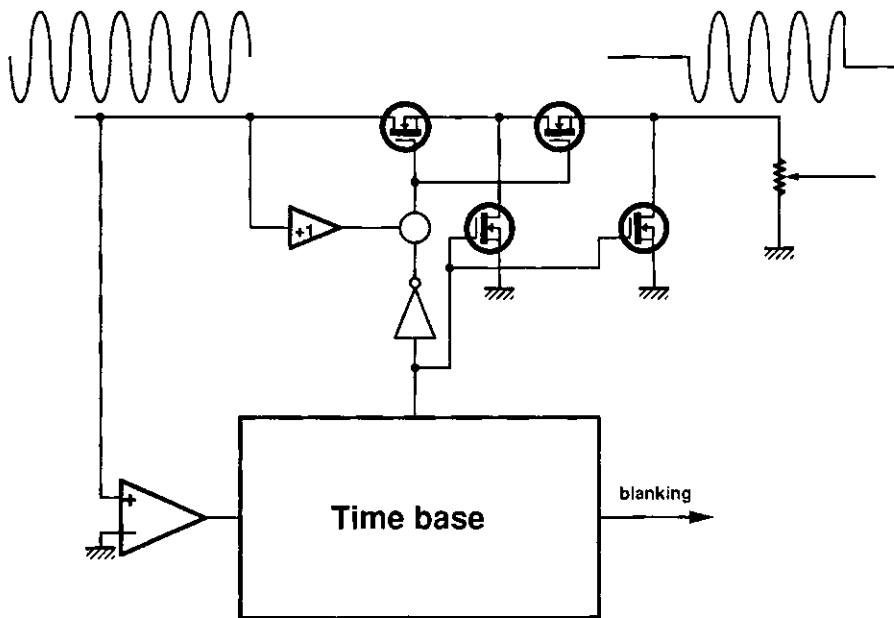

Figure 4 : Generation of the test tone-burst.

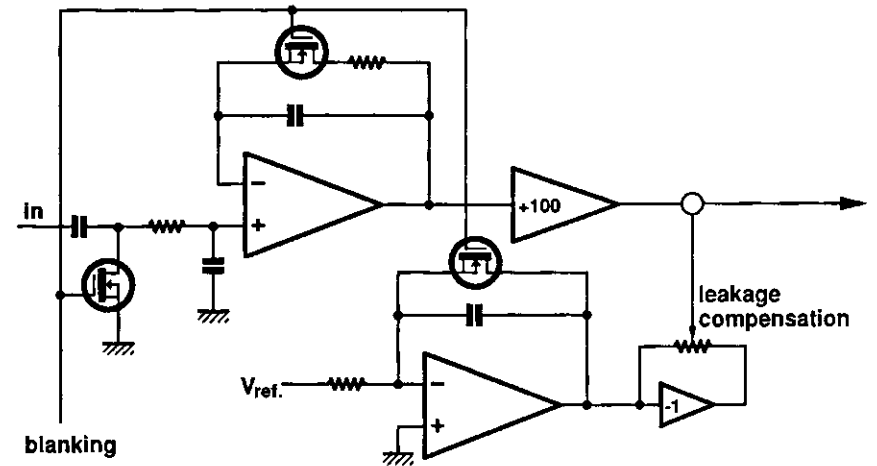

Figure 5 : Preamplifier used for analysing the drift induced by memory.

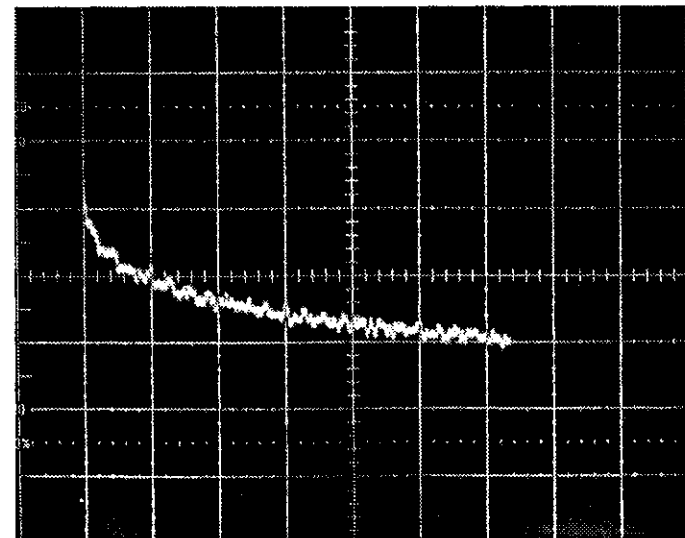

Figure 6 : Drift of the DC amplifier for a square wave output signal of $\pm 3V$ pk-pk across a 4Ω load. Scales are 1 mV/div. and 10mV/div.

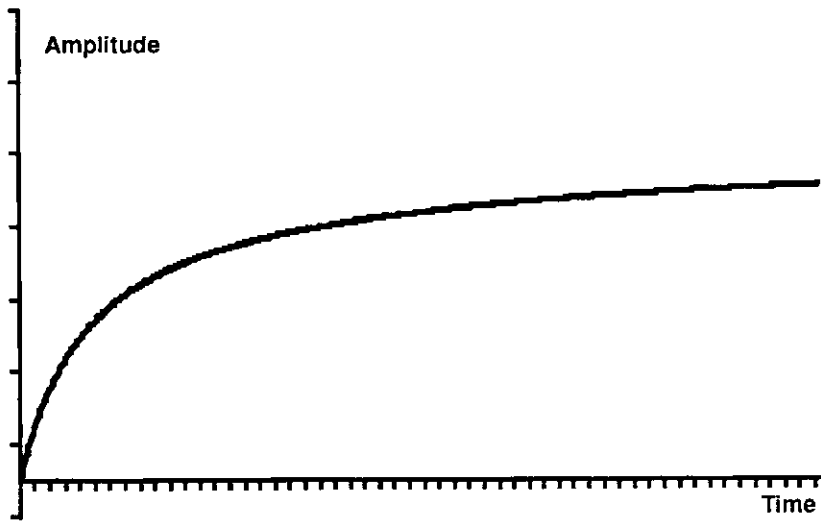

Figure 7 : Drift simulated on a computer.

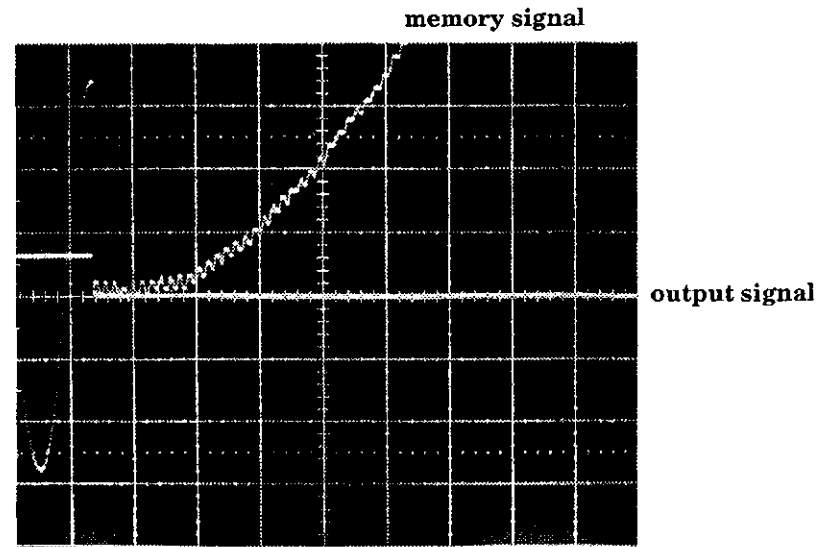

Figure 9 : Output signal (2V/div.) and memory signal (2 mV/div.) for a tube amplifier. Time scale is 10 ms/div. The curvature is induced by a second low-frequency pole.

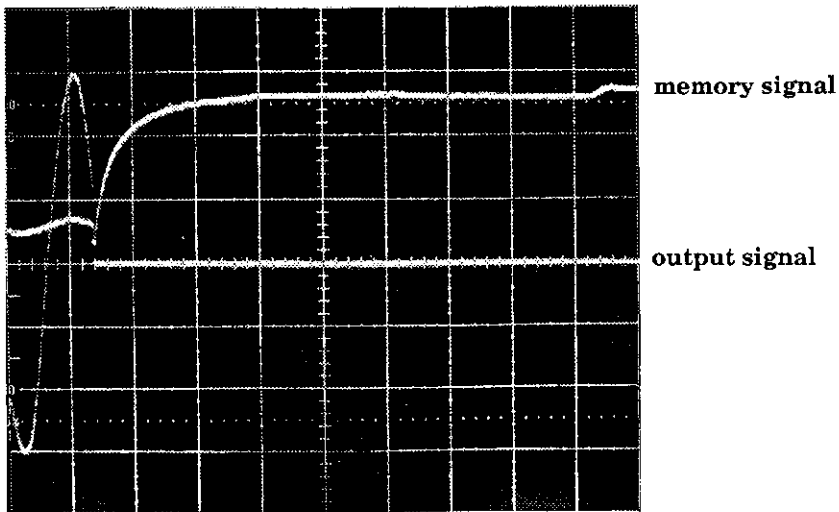

Figure 8 : Output signal (2V/div.) and memory signal (1 mV/div.) for a classical transistor amplifier. Time scale is 10 ms/div.

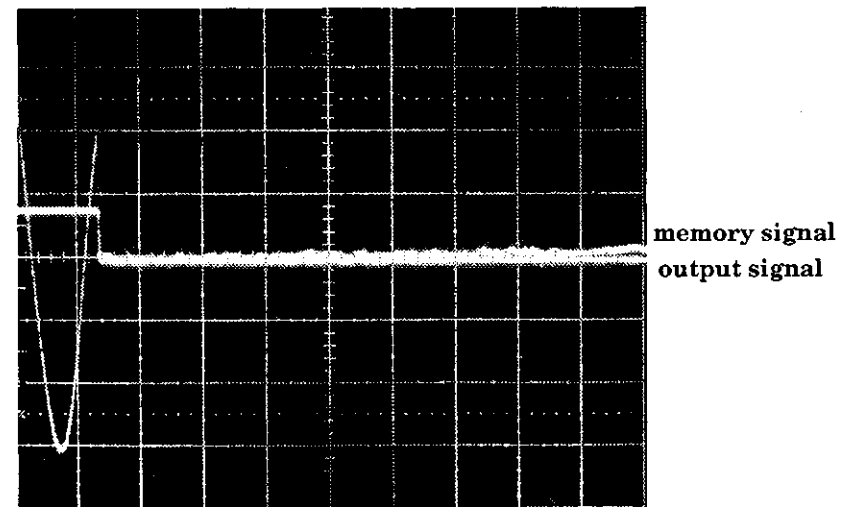

Figure 10 : Output signal (2V/div.) and memory signal (0,5 mV/div.) for a transistor amplifier using a new memory free technology. Time scale is 10 ms/div.