

5

**ACOUSTAT
TRANS-NOVA
TWIN-200
POWER
AMPLIFIER**

Manufacturer's Specifications

Power Output: 200 watts per channel, 8 ohms, 20 Hz to 20 kHz; 325 watts per channel, 4 ohms, 20 Hz to 20 kHz.

THD: 0.1%.

SMPTE-IM Distortion: 0.1%.

Damping Factor: Greater than 1,000 at all frequencies below 1 kHz; greater than 100 at 20 kHz.

Slew Rate: 165 V/ μ S.

Input Impedance: 47 kilohms.

Input Sensitivity: 1.3 volts.

Output Impedance: Forward driven, 0 to 1 kHz, 40 milliohms at 20 kHz; 200 milliohms at 50 kHz.

Power Consumption: 100 watts idling, 750 watts at rated power.

Dimensions: 17 in. (43.18 cm) W \times 5 in. (12.7 cm) H \times 14 in. (35.56 cm) D.

Weight: 40 lbs. (18 kg).

Price: \$1,095.00.

Company Address: 3101 Southwest First Terr., Fort Lauderdale, Fla. 33315.

For literature, circle No. 94



Fig. 1—Schematic diagram of one channel, Acoustat TNT-200 amplifier.

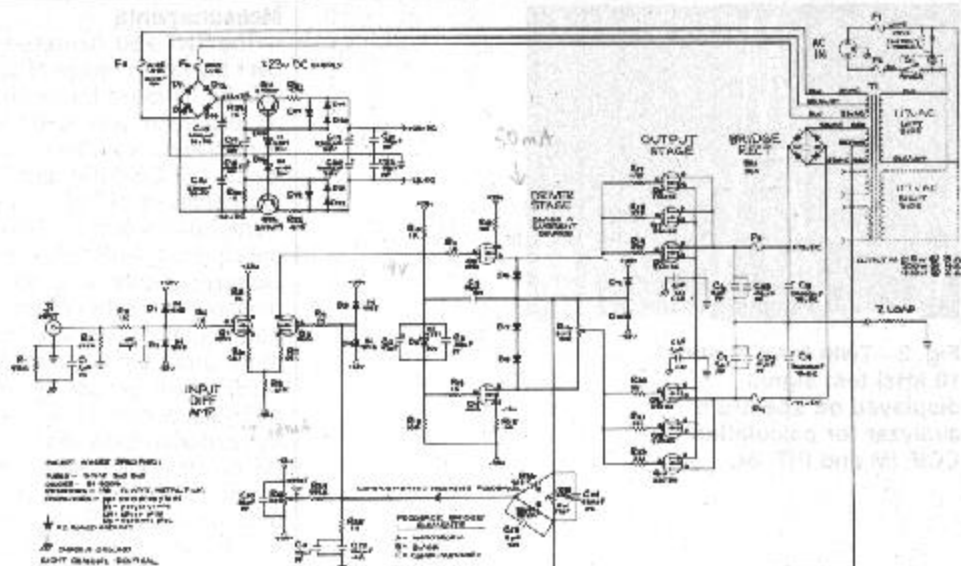

The search for the perfect power amplifying circuit goes on. This time it's Acoustat Corporation, which claims to have come up with the long sought-after answer in the Trans-Nova Twin-200 power amp. Trans-Nova is an acronym for "Trans-conductance Nodal Voltage Amplifier." Most power amplifier output stages are typically configured either as voltage followers or as transconductance stages (common in tube-type amplifiers). When Acoustat decided to design an amplifier employing MOS-FETs as power output devices, they found that neither of these basic configurations was well suited to such ICs.

The follower type of circuit is not ideally suited to the power MOS-FET because it does not allow use of either full positive-to-negative supply-voltage dynamic range or gain-bandwidth product. The transconductance stage is also not ideally suited to the power MOS-FET, since pure transconductance-mode operation of an output stage requires large amounts of multistage or long-loop negative feedback.

So Acoustat came up with a third alternative, which they call an anisotropic output configuration (anisotropic: Having different properties in different directions). A schematic diagram of one channel is shown in Fig. 1. The circuit departs from the usual bipolar amplifier design approach of having a voltage-gain stage driving a current-gain output stage. Instead, it uses voltage-to-current conversion followed by current-to-voltage conversion. In this arrangement, the first stage is called a transconductance stage ($g_m = I/E$), while the second stage is called a transresistance stage ($r_m = L/I$). The first stage has near-infinite generator impedance (and therefore zero damping); the voltage errors of the second power stage are totally returned to the first stage's input gates, to create an output characteristic equivalent to a unity-gain stage. In fact, while the output stage has every desirable property of a no-gain stage (low distortion and noise with high damping and speed), it also exhibits full open-loop voltage gain of around 20 dB into 8 ohms together with full rated power, headroom and speed.

A second important circuit innovation in the TNT-200 is called Complement Feedback. According to its inventors, this is an improvement on classic negative feedback; it looks at signal error inside the classical feedback loop, as well as outside it, and then further refines the feedback signal to cancel output-stage distortion and impedance. In the circuit diagram of Fig. 1, the feedback circuit elements identified with the letter "A" represent Acoustat's anisotropic feedback elements. The RC network identified with the letter "B" represents the conventional feedback elements based upon the famous H. S. Black patent (1937). The complemented negative-feedback element "C" creates an intra-loop error-return path that results in "infinite" error gain without the problems of instability described by Bode and Nyquist.

This circuit design eliminates any need for current-limiting protection against load faults. Neither are inductors needed in the output path to insure stability (and possibly cause sonic aberrations with certain unusual loads). As is evident from the schematic diagram, only FETs are used in the signal path. The bipolar devices identified as Q11 and Q12 are merely part of the 23-V d.c. supply regulating circuit.

So much for the theory. Now let's have a look at the amplifier itself. The front panel is totally devoid of any controls, with the exception of its rocker-type power on/off switch. A rather prominent nameplate identifies the maker and the product. As for the rear panel, most of it is taken up with a massive heat sink, but there is just enough room at either end to accommodate color-coded, five-way output binding posts and an input jack for each channel. This sort of channel isolation is carried on inside the chassis as well, with completely separate modules housing the parts for each channel. Six fuses are located internally (four d.c. supply-voltage line fuses and two a.c. line fuses). The TNT-200 uses four completely separated bilateral power supplies and a twin-core, quasi-toroidal power transformer with parallel primaries.

"When Acoustat found the basic power amp output configurations weren't suited for MOS-FETs, they devised the anisotropic output configuration."

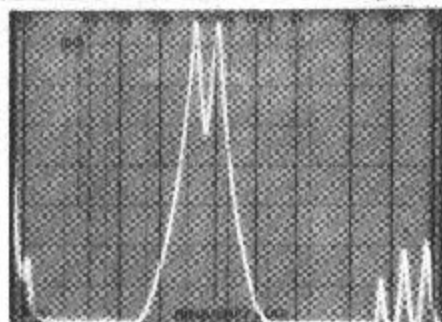

Fig. 2—Twin-tone (9 and 10 kHz) test signal displayed on spectrum analyzer for calculation of CCIF IM and IHF IM.

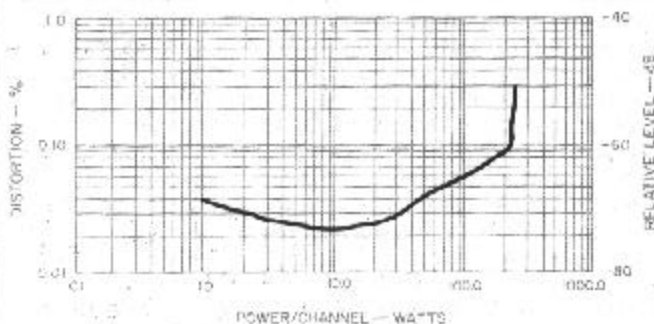

Fig. 3—Power output per channel vs. harmonic distortion, 1-kHz test signal, 8-ohm loads.

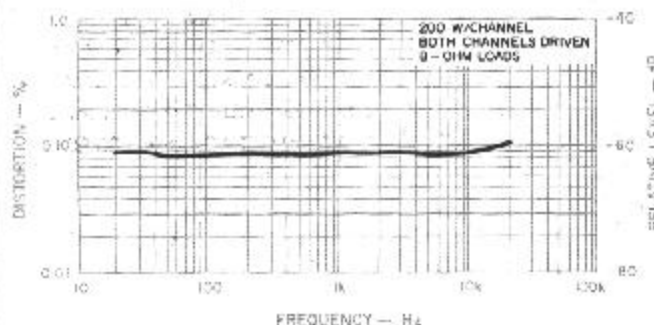

Fig. 4—Harmonic distortion vs. frequency.

Measurements

The TNT-200 delivered just over 200 watts per channel over the entire range of audio frequencies from 20 Hz to 20 kHz for its rated harmonic distortion level of 0.1%. SMPTE-IM distortion was a bit higher than claimed, rising to a nonetheless inaudible 0.2% for rated output into 8-ohm loads, but CCIF IM and IHF IM, calculated from the spectrum analysis of Fig. 2 (linear sweep from 0 Hz to 20 kHz), were 0.046% and 0.149% respectively. Dynamic headroom measured 1.4 dB, while IHF slew factor was greater than 5. Damping factor was obviously higher than I was able to measure in the bench setup, even though I used short, 14-gauge connecting wire from the amplifier's output terminals to the input terminals of the test instruments.

IHF input sensitivity (for 1-watt output) measured 100 millivolts; sensitivity for rated output was 1.4 volts. Frequency response extended from 4 Hz to 135 kHz between -1 dB cutoff points, and from 2 Hz to 400 kHz for a -3 dB cutoff. Signal-to-noise ratio, referenced to rated output, measured 109 dB (A-weighted). Figure 3 is a plot of harmonic distortion versus power output, for a 1-kHz signal driving an 8-ohm load. When the load was switched to 4 ohms, maximum power output per channel was 325 watts, as claimed. I lowered the load impedance to 2 ohms briefly, and under those load conditions the amplifier was able to deliver in excess of 400 watts per channel to the load. A 1- μ F capacitor, paralleled across the 8-ohm resistive load on each channel, did not result in any instability. Figure 4 is a plot of harmonic distortion versus frequency for the 8-ohm load condition.

Use and Listening Tests

I am not prepared to say that the sound of the Acoustat TNT-200 is markedly superior to that of several other high-grade power amplifiers I have listened to in recent months. I did note an effortlessness in the way the amplifier delivered power to a variety of loads, and an almost complete transparency of sound which characterizes several previously favored amplifiers. It has been said that FETs behave more like tubes than do bipolar devices, and indeed that is true. Since I never became emotionally involved in the debate over "tube sound versus transistor sound," as have some of my colleagues, I can't honestly say the sound of the Acoustat TNT-200 replicates that of any tube amplifier of yesteryear. Nor would I want it to. The Acoustat's sound merits serious consideration and auditioning in its own right. It's a clean and robust sound that appeals to me.

With an amplifier capable of producing this level of power, it's important to consider some qualities which are not sonically related, such as long-term reliability. The fact that Acoustat offers a limited 5-year warranty is an encouraging sign. Perusal of the components in this sturdily built amplifier gave further evidence that it is not likely to require frequent service. I suspect the reason for the relatively high cost of the TNT-200 is the high cost of those MOS-FETs and the rest of its bill of materials. Perhaps, in time, amplifiers built this way will come down in price as more and more serious listeners begin to appreciate the virtues they offer and stop measuring amplifiers on a watts-per-dollar basis.

Leonard Feldman

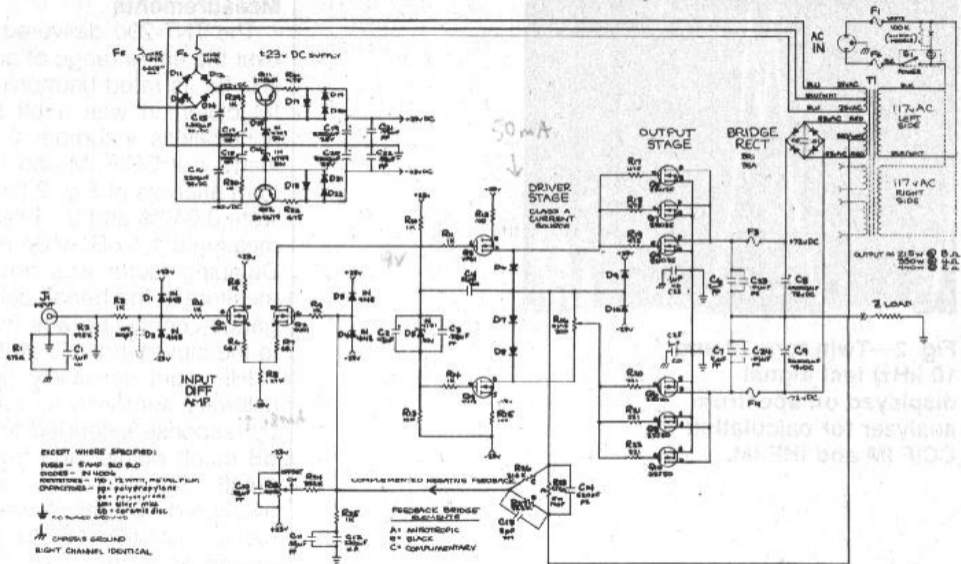

EXCEPT WHERE SPECIFIED:

FUSES - 5AMP 5/16 DIA

DIODES - 2N1400A

RESISTORS - 1/4W, 1% TOL, METAL FILM

CAPACITORS - pp = POLYPROPYLENE

PE = POLYESTER

SP = SILICON

CD = CERAMIC DISC

AC SYMBOLS 250V-10

CHASSIS GROUND

RIGHT CHANNEL IDENTICAL

