

Development of Horn Loudspeakers Before 1940

Bjørn Kolbrek

Acoustics Research Centre, Department of Electronics and Telecommunications NTNU–Norwegian University of Science and Technology, Trondheim, Norway

Summary

During the period between approximately 1920 and 1940, an enormous amount of research on electroacoustics was done at the Bell Telephone Laboratories (BTL), and at RCA. This work resulted in great advances in loudspeaker technology, sound recording and reproduction and, not to forget, the first commercially successful sound motion pictures. Significant contributions to current sound reinforcement technology come from the pioneering work at BTL, and even some of the modern implementations are not very different from the original designs. Advances were also made in Europe, most notably in Germany and Great Britain, but at a smaller scale. This paper presents some of the acoustic and electroacoustic research during this period, the main focus being on horn loudspeakers, but related technologies and some of the people involved are presented as well. Some heretofore unpublished historical details and unique photographs from the AT&T Archive and History Center are presented, casting light on the rapid development and commercialization of sound motion pictures at BTL.

PACS no. 43.38.Ja, 43.10.Eg

1. Introduction

This paper will mainly deal with the research done at the Western Electric Engineering Department (W.E. E.D.), which from 1925 became the Bell Telephone Laboratories, BTL). Both organizations will be referred to as BTL in the rest of the paper. Due to space and copyright issues, many of the photos will only be shown during the presentation at the conference. Also due to space restrictions, the main focus will be on the less known parts of this history. Excellent accounts on the history of electroacoustics have been given elsewhere [1, 2, 3, 4], and the interested reader is referred to these accounts, and to the other references in this paper, for the history not covered here.

While horns have been used in one form or another for thousands of years, the mathematical analysis and utilization on a large scale was, to a large degree, not undertaken until early in the 20th century. Eisner [5] gives an account of the early history of the so-called horn equation, dating back to the 18th century, and shows that it was analyzed by d'Alembert, D. Bernoulli and Euler in the 1760's and 70's. After this, little happened until the 20th century, with a few exceptions. It was not until Rayleigh in 1916 [6], and

Webster in 1919 [7] published their papers, that the real progress started.

The development of the phonograph and gramophone in the late 19th century made clear the need for horn technology. As these devices were purely mechano-acoustical, the energy from the needle had to be transferred as efficiently as possible to the air, and it was early realized that a horn would improve the playback volume. This work was empirical, though, and no attempt was made to analyze or predict the optimal shape of the horn. In most cases, small conical horns were used, often with a short flare at the mouth end.

Radio and gramophone steadily advanced the arts of sound reproduction. But when sound film finally was realized in commercial form with the Vitaphone in 1926, the pace of development increased enormously. The resources poured into audio research at that time may be compared to the space race of the 1960s, or the development of the internet. BTL spent \$1,250,000 on research related to sound recording and reproduction in 1929 alone. It was cutting edge technology with BTL at the forefront. Scientists of the caliber that worked in audio research in the 1920s and 1930s would in later decades have been working on nuclear physics or top-level military projects.

2. Dynamic Analogies

Perhaps the most influential paper in the history of horn technology is the paper by Arthur Gordon Webster in 1919[7], the content of which had been presented a few years before. Here Webster introduced the concept of acoustic impedance, and analyzed several horn shapes.

It had been known for some time that the differential equations for electrical, mechanical and acoustical systems were of similar form [8]. It seems, however, that it was Webster that made the engineering community aware of the fact that the impedance concept from electrical circuit theory could also be used in analyzing acoustical systems. This idea was soon exploited to a large degree by H.C. Harrison, an engineer and inventor at the BTL with 127 patent applications. He applied the Matched Impedance viewpoint to mechanical and electromechanical systems, which in turn led to the use of electrical network theory in the design of these systems.

At this time, a large research project on speech and hearing was underway at BTL[9, p. 929]. For this work, a system was needed to record and reproduce sound faithfully, for later analysis. Groups worked simultaneously with sound recording on film and disc. In 1922 the disc recording group, led by J. P. Maxfield, had an experimental electrical recording system in operation. This system was commercialized in 1925, and licenses sold to Victor and Columbia.

By using the impedance analogy, and describing the mechanical system transmitting energy from the gramophone needle to the input of the horn as a band-pass filter, the scientists at BTL were able design a gramophone covering a much larger frequency range than had been possible until then [10, 11]. The result was the Orthophonic gramophone, which combined with the new electrical recording system, provided a major lift in the quality of reproduced sound. Harrison also introduced the exponential horn to BTL [12, 13, 14], which was another reason for the improved response of the new gramophone.

3. Loudspeaker Technology

The speech and hearing research at W.E./BTL, in addition to the improvement and commercialization of vacuum tube amplifiers, resulted in several products beside improved telephone transmission. One of these was a public address system [17] using large conical horns. The first major demonstrations of this system were at the 1920 presidential conventions, and at the inauguration of President Harding in March 1921. But it was perhaps Harding's dedication of the Tomb of the Unknown Soldier on November 11, 1921, that was the major boost for this system. Harding's speech was transmitted from the Arlington National Cemetery over telephone lines to loudspeakers in New York

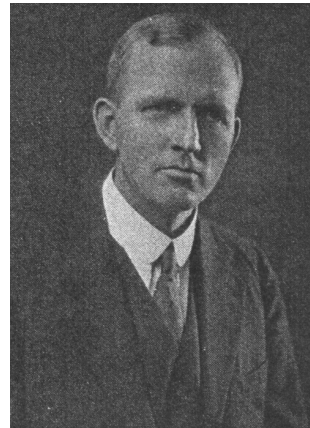

(a) H.C. Harrison



(b) D.G. Blattner



(c) E.C. Wente



(d) A.L. Thuras

Figure 1: Some BTL scientists involved in loudspeaker development [14, 15, 16]

and San Francisco[18]. By the end of 1922, the W.E. public address system was a standard.

In England, Paul Voigt, working for Edison Bell, Ltd., also made many contributions to sound recording and reproduction, including an electric recording system, and a moving coil loudspeaker that he was less than a month too late to have patented, beaten by Rice and Kellogg[19, 20]. Voigt's main contribution to horn technology is the use of the Tractrix curve as a horn profile[21]. He designed several horns using this curve, both a large cinema horn, and a smaller corner horn for domestic use.

4. Sound Film

E. B. Craft at BTL became interested in exploiting the sound recording and reproduction research towards the motion picture industry. Due to many past failures, some of them expensive, the industry believed that sound film would not work. The major players in the industry were completely uninterested[18]. One exception was the Warner

brothers, who were looking for something new to expand their market share. Walter Rich of W.E. and the Warners formed the Vitaphone Corporation on June 25, 1925, to exploit the W.E. system commercially. On April 20, 1926, after enough of the initial problems were overcome, Warner and AT&T signed a contract giving the Vitaphone Corp. an exclusive license to produce sound films using the W.E. equipment, and to equip theaters with W.E. reproduction equipment. January 1, 1927, Western Electric formed a new subsidiary to take care of their sound picture and other non-telephone business, Electrical Research Products Inc. (ERPI).

The summer of 1926 saw high activity in the BTL. The reading of the internal communication at BTL gives interesting insight into the intense activity at the laboratories during this time.

E. C. Wentz and A. L. Thuras developed a new moving coil horn driver, the Western Electric 555-W compression driver. It was ready just in time for the Vitaphone premiere August 6. The patents for the driver were filed two days before the premiere [22, 23]. The first 20 drivers were built in the Model Shop (at BTL)¹, and some tests had been performed by the end of July. There were still tests to be performed, but due to the circumstances, BTL advised W.E. to proceed with manufacture, to have the Vitaphone perform as good as possible from the start.

The 555-W driver has several features found in modern compression drivers, such as a metal diaphragm, a phasing plug, and an edge wound aluminium voice coil, and efficiency in the 30% range [24]. Less common is the large frequency range this driver was designed to handle, 60Hz to 4kHz. The phasing plug and diaphragm shape are also not often found in modern high frequency drivers, and neither is the field coil used to provide the magnetic field in the voice coil gap. The 555-W was a giant leap forward, providing better sound quality than any other driver at the time, and with higher efficiency. It is a remarkably good compression driver within its frequency range even by modern standards, and is now an expensive collector's item.

D. G. Blattner was in charge of the horn development [25]. This fact seems to be very little known, despite numerous horn patents issued in his name, but he was instrumental in the work leading up to the final Vitaphone designs.

It was not at first clear what horns should be used for the Vitaphone system. The Ortophonic horn was probably considered at some point, but other horn samples were also obtained by Maxfield². The final design of the horn was not ready, but it was already planned by May 1926 that the Victor Talking Machine Company would manufacture the horns.

BTL furnished the Victor Company with designs, showing the internal profile³ ⁴, which Victor in turn produced samples of [26]. Two 11' and two 14' designs were submitted for testing. These horns were tested June 23th to 25th, 1926.

A 5th horn, 14' long, brought in for new tests about a week later (July 1st), had good low frequency response, but lacked smoothness and brilliance. The improved LF response was judged more important for orchestral work, and it was decided to use it in conjunction with one of the 11' horns, described as a "conch shell" horn. It was also desired to redesign the latest horn to the same folding as this 11' horn, but this was not undertaken until much later due to the urgency of making the Vitaphone equipment ready.

The two horns were coded 12-A and 13-A, respectively³ [27]. The 12-A was to be hung at the top edge of the screen, and 13-A was to be placed in the orchestra pit. Two to three 12-As and one to two 13-As were usually required.

The RCA sound film system, which was based on the Fox-Case sound-on-film system, used cone drivers instead of compression drivers. Their first loudspeaker system was based on columns of the Rice-Kellogg moving coil loudspeaker on each side of the screen. Later, H. F. Olson developed an exponential baffle or short horn that was used with similar drivers [28].

C. R. Hanna of Westinghouse also designed compression drivers, and advocated the use of dividing networks to increase the capacity of the system by dividing the frequency range into several bands [29].

5. Improved Theatre Horns

The 12-A and 13-A horns were expensive to manufacture. Figures for an order of 500 horns [30] were \$245.10 for the 12-A and \$295.55 for the 13-A, corresponding to \$13,400 and \$16,200 today, according to <http://www.measuringworth.com/>. Construction of the horns was also "somewhat difficult" [31] due to the curved surfaces, and a great amount of hand fitting was necessary. The horns

"had to be entirely constructed from small narrow slats each one having a different size and shape from its neighbor. These slats had to be hand fitted and glued together in a number of special wooden forms." [32]

Even during the initial tests of the horns, a redesign of 13-A to the shape of 12-A had been contemplated, but this was not undertaken until some time in 1928. One step in the process was a series of fabric horns built by Racon. Subsequently, several plywood horns were tested, where the first 6' of the horn was made of metal, and it was found that when the plywood part

¹ Letter to Wilcox, July 31, 1926 (case 33218)

² Gilson to Mather, Apr 21, 1926 (case 33218)

³ Lyng to Wilcox, Jul 9, 1926 (case 33218)

⁴ Glunt to Kasley, Jul 29, 1926 (case 33218)

was made from basswood, quite smooth response was obtained. A model, built from 7/8" wood slats in the same manner as 12-A and 13-A⁵, was also tested.

D. G. Scrantom at Hawthorne patented a method to manufacture these horns, designated 15-A, using bent struts made from rock elm, to which the 3-ply basswood plywood is attached [33]. This method permitted cheap and rapid manufacture of these horns, with as many as 275 horns per week by the end of the first quarter of 1929 [34].

The early tests of 15-A showed it to be "somewhat shrill" compared to the old 12-A and 13-A horns, and a piece of canton flannel was glued to the inside of the horn through the bend to reduce the high frequency output.

The 15-A horns seem to have been very successful, and they were in production from 1928 to 1938⁶.

There were however problems of fitting the 52 inches deep 15-A horn behind some screens [35]. Theaters like the Roxy had very limited space behind the screen, and originally 4 12-A horns, mounted in two towers, one at each side of the screen, were used. This was not satisfactory, as it did not give the desired illusion or distribution⁷. The first remedy was the so-called "ram's horn", KS-6576, another of the fabric horns produced by Racon, where the sound passage-way was split in two. Several variations of this theme were tried, and both plywood and steel horns were built. The final version is known as the 16-A horn. The horn is made up of two parts with a common mouth 44 by 60 inches. The first bend starts 14" back from the mouth. It is a 57Hz horn, the same as 15-A. It was in production by mid-1930. It obviously inspired others, and both Fox and Vitavox made their versions, Vitavox even patented theirs [36]. See Figure 2.

There are also interesting developments of the 15-A horn that should be mentioned. In mid-1928 a so-called slit mouth horn is tested, where the mouth section of the 15-A is replaced by a multi-cellular variant [38]. This was to improve the high frequency directivity, and claims of improved low frequency response are also made in the patent.

As recording technology improved, the need for better high frequency response was felt. The development of what would become the 596/597 tweeter [39], was under way in 1928⁵, and was close to production ready in 1931[40]. Tool made samples were available at this point. It was acknowledged that the recording apparatus in use at the time was unlikely to be able to utilize the full potential of this tweeter, and that an equalizer would be required to cut off the upper frequencies. This was regarded as the most attractive

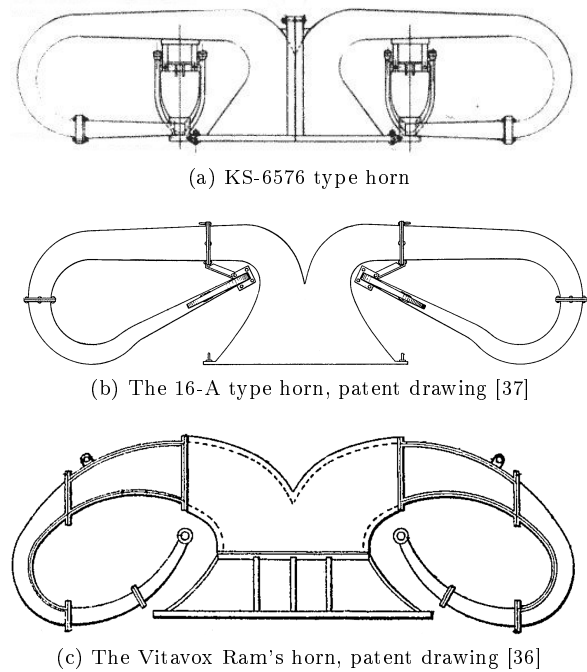

Figure 2: Ram's Horn variants

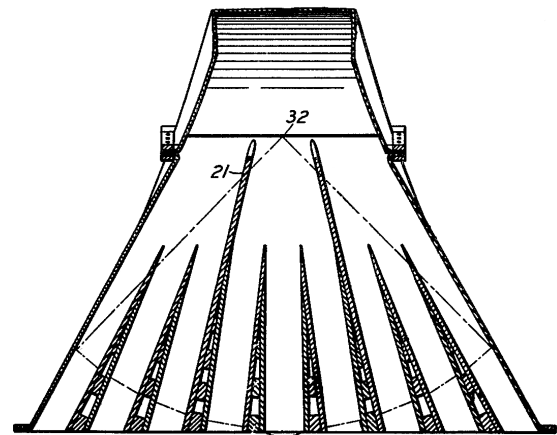

Figure 3: 15-A type horn with slit mouth

possibility for extending the high frequency range⁸. The long delay from development to production was mainly due to lack of interest on the part of ERPI before that time⁹.

Simultaneously, a modification of the 555 to allow the high frequencies to radiate from the rear side of the diaphragm, was investigated. This was later patented[41]. It was deemed a less desirable solution than using a tweeter, since the horns had to be modified. Other work on modifying the 555 to be able to radiate up to 8kHz is also mentioned.

⁵ Blattner to Frederick, Jul 25, 1928 (case 33218)

⁶ Mali to Weigand, March 15, 1938 (case 53101)

⁷ Santee to Glunt, Nov 12, 1928

⁸ Mather to Glunt, Apr 1, 1931

⁹ Jones to Charlesworth, December 2, 1931 (Case 53901)

6. Auditory Perspective

From a quite early point, BTL had close cooperation with the director Leopold Stokowski, who had a keen interest in sound recording, reproduction and the technology behind the process. This cooperation led to a series of pioneering experiments in recording and reproduction of orchestral music, in “Auditory Perspective”, or what we today would call three-channel stereo.

Stokowski’s idea was to be able to reproduce, simultaneously and at several locations, the sound of a full orchestra playing at one location, in the most realistic manner possible. And not only that; Stokowski wished to use the sound system to enhance the experience of the orchestra by manipulation of equalization and dynamic range.

The system developed in this project has become known as the Fletcher system. Space does not permit a full description of this fascinating and powerful system, and the interested reader may consult the references [42, 43, 44, 45].

It should however be mentioned that the high-frequency compression driver developed for this system, later commercialized as the W.E. 594A, has been the very definition of compression driver design ever since. A 4” domed diaphragm with an edgewound aluminium voice coil, working through a concentric-slit phasing plug and a 2” throat, are still the main ingredients of large-format compression drivers. When it went out of production in 1938, no driver of comparable power output was available until Locanthi designed the JBL 375 in 1954.

7. Towards 1940

The Fletcher system set a standard of quality that was desired by the motion picture industry, but Western Electric was not interested in developing a commercial version.

In 1934, Shearer at MGM gave John K. Hilliard the task of developing a new loudspeaker system. Hilliard’s team used the Fletcher system as a reference, and developed a new system that remedied many of the problems of the Fletcher system. This included the large path length difference between the two horns, the large size of the bass horn, and the high cost. The resulting Shearer system won the Academy of Motion Picture Arts and Sciences Technical Award in 1936. It was produced by Lansing Manufacturing and RCA, and perhaps also by W.E., although this may be a misunderstanding based on the visual similarity of the W.E. Mirrophonic system. Only Lansing Mfg. used the Shearer name.

The Mirrophonic system, produced only 1937–1938, also used a large multicellular horn and a bass horn in a large baffle. Their multicellular horn, however, used the W.E. 594A 2” exit compression driver, and the

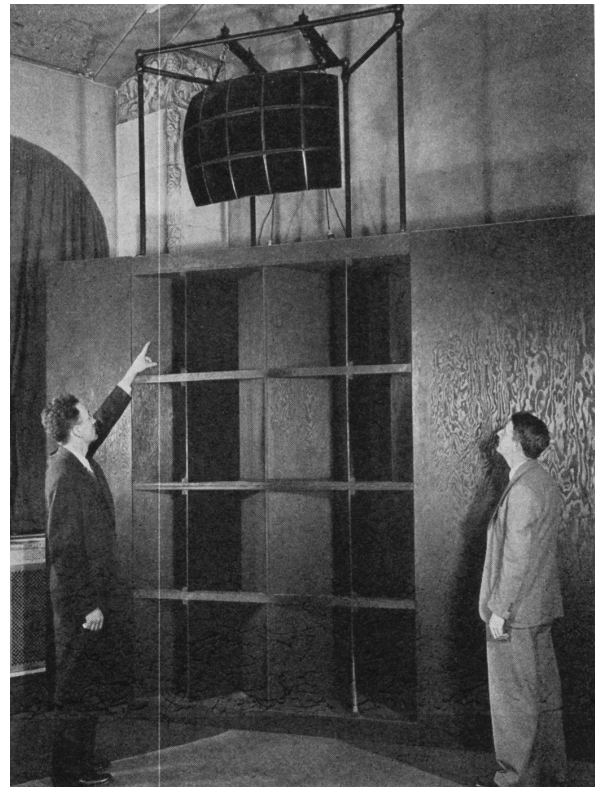

Figure 4: The W.E. Mirrophonic System [46]

bass horn was not folded, shorter than the Shearer horn (making zero path length difference possible), and used two or four 18” cone drivers. This horn is more a directional baffle than a real horn, and was developed experimentally[46, 47].

8. CONCLUSIONS

The loudspeaker development at BTL laid the foundation for much of the later high-fidelity technology. Recent investigations reveal that some of the BTL work, in particular the development of the Vitaphone, was much more rushed than previously thought.

This paper has only been able to cover a small part of the work done, so the main focus has been on the part of the history that is less known or previously unpublished. It is hoped that the new information provided may be of interest to historians and collectors.

Acknowledgement

Thanks to Thomas Dunker, with whom I have worked for over 10 years collecting the information presented above. A great thank you goes to George Kupczak at the AT&T Archives and History Center, for letting us in and helping us finding the material we were looking for.

All images (except patent drawings) courtesy of AT&T Archives and History Center.

References

- [1] F. V. Hunt: *Electroacoustics*. Harvard University Press, 1954.
- [2] J. K. Hilliard: Historical review of horns used for audience-type sound reproduction. *J. Acoust. Soc. Am.* **59** (Jan 1976) 1–8.
- [3] J. K. Hilliard: *Electroacoustics to 1940*. *J. Acoust. Soc. Am.* **61** (Feb 1977) 267–273.
- [4] M. Schildbach: Audio technology in Berlin to 1943: Headphones and Loudspeakers. 94th Convention of the Audio Engineering Society (Mar 1993).
- [5] E. Eisner: Complete Solutions of the Webster Horn Equation. *J. Acoust. Soc. Am.* **41** (1966) 1126–1146.
- [6] J. W. S. Rayleigh: On the Propagation of Sound in Narrow Tubes of Variable Section. *Phil. Mag.* **31** (1916) 89–96.
- [7] A. G. Webster: Acoustical Impedance and the Theory of Horns and of the Phonograph. *Proc. Nat. Ac. Sci.* **5** (Jul 1919) 275–282.
- [8] W. P. Mason: *Electromechanical Transducers and Wave Filters*. D. Van Nostrand Co., New York, 1942.
- [9] M. D. Fagen (ed.): *A History of Engineering and Science in the Bell System — The Early Years (1875–1925)*. Bell Telephone Laboratories, Inc., 1975.
- [10] J. P. Maxfield, H. C. Harrison: Methods of High Quality Recoding and Reproduction of Music and Speech based on Telephone Research. *Bell System Technical Journal* **5** (Jul 1926) 493–523.
- [11] H. C. Harrison: Acoustic Device, US Patent no. 1730425 (Oct. 11 1927).
- [12] H. C. Harrison: Improvements in Acoustic Horns, British Patent no. 213528 (Mar. 28 1923).
- [13] H. C. Harrison: Acoustic Horn, US Patent no. 1747830 (Oct. 6 1928).
- [14] Contributors to this issue: H. C. Harrison. *Bell Laboratories Record* **10** (Jul 1932) 403.
- [15] Contributors to this issue: D. G. Blattner. *Bell Laboratories Record* **9** (Mar 1931).
- [16] Contributors to this issue: A. L. Thuras. *Bell Laboratories Record* **10** (May 1932) 340.
- [17] I. W. Green, J. P. Maxfield: Public Address Systems. *J. Am. Inst. Elec. Eng.* **42** (Apr 1923) 347–358. Reprinted in *J. Audio Eng. Soc.*, vol. 25, no. 4, April 1977.
- [18] S. Hochheiser: AT&T and the Development of Sound Motion-Picture Technology (1989) 23–33.
- [19] B. C. Edgar: An Interview with Paul Voigt, part 1. *Speaker Builder* (1981) 12–16.
- [20] B. C. Edgar: An Interview with Paul Voigt, part 2. *Speaker Builder* (1981) 14–15, 19–20, 22–24.
- [21] P. G. A. H. Voigt: Improvements in Horns for Acoustic Instruments, British Patent no. 278098 (Jul. 5 1926).
- [22] E. C. Wente: Acoustic Device, US Patent no. 1707545 (Aug. 4 1926).
- [23] A. L. Thuras: Electrodynamic Device, US Patent no. 1707544 (Aug. 4 1926).
- [24] E. C. Wente, A. L. Thuras: A High-Efficiency Receiver for a Horn-Type Loudspeaker of Large Power Capacity. *Bell System Technical Journal* **7** (Jan 1928) 140–153.
- [25] Stanley Watkins: Madam, Will You Talk. *Bell Laboratories Record* **24** (Aug 1946) 289–295.
- [26] David G. Blattner: Receiver and Horn Tests at Manhattan Opera House – Case 33218. *Memorandum*, July 2 1926.
- [27] W. J. Leveridge: 12-A and 13-A Horns for Vitaphone – Case 33218. *Memorandum*, Jul 27 1926. (311-WJL-7/27/26-ZB2).
- [28] H. F. Olson: A New High-Efficiency Theatre Loudspeaker of the Directional Baffle Type. *J. Acoust. Soc. Am.* **2** (Apr 1931) 485–498.
- [29] C. Hanna: Loudspeakers of High Efficiency and Load Capacity. *Trans. Am. Inst. Elec. Eng.* (1928) 607–614.
- [30] W. J. Leveridge: 12-A and 13-A Horns for Vitaphone – Case 33218. *Memorandum*, Jul 29 1926. (311-WJL-7/29/26-BB1).
- [31] W. J. Leveridge: 12-A and 13-A Horns for Vitaphone – Case 33218. *Memorandum*, Jul 27 1926. (7/27/26-311-WJL-YU2).
- [32] W. J. Leveridge: 12-A and 13-A Horns for Vitaphone – Case 33218. *Memorandum*, Jul 27 1926. (311-WJL-7/27/26-AAS2).
- [33] D. H. G. Scramton: Apparatus for Amplifying and Distributing Sound Waves, US Patent no. 1852793 (Nov. 24 1928).
- [34] *Items of Interest*. Vol. 10. Hawthorne Plant, 1929.
- [35] H. B. Ely: A Shallow Horn For Theatre Use. *Bell Laboratories Record* **9** (Jun 1931) 241–243.
- [36] L. Young, A. Young: Improvements in or relating to Acoustic Horns for Sound Reproducing Instruments, British Patent no. 403634 (Jun. 22 1932).
- [37] D. G. Blattner: Acoustic Device, US Patent no. 1853955 (Jun. 25 1930).
- [38] D. G. Blattner: Horn, US Patent no. 2001089 (Apr. 7 1933).
- [39] L. G. Bostwick: Sound Reproducing Device, US Patent no. 1907723 (Sept. 28 1929).
- [40] C. Flannagan: Improvements in Loudspeakers and other equipment – Case 53901. *Memorandum*, Mar 28 1931.
- [41] E. C. Wente: Acoustic Device, US Patent no. 1930915 (Jul. 13 1932).
- [42] R. E. McGinn: Stokowski and Bell Telephone Laboratories. *Technology and Culture* **24** (Jan 1983) 38–75.
- [43] E. C. Wente, A. L. Thuras: Symposium on Wire Transmission of Symphonic Music and Its Reproduction in Auditory Perspective: Loudspeakers and Microphones. *Bell System Technical Journal* **13** (Apr 1934) 259–277. Reprinted in *J. Audio Eng. Soc.*, vol. 26, no. 7/8, Jul/Aug 1977.
- [44] H. Fletcher: Symposium on Wire Transmission of Symphonic Music and Its Reproduction in Auditory Perspective: Basic Requirements. *Bell System Technical Journal* **13** (Apr 1934) 239–244.
- [45] A. L. Thuras: Loudspeakers and Microphones for Auditory Perspective. *Bell Laboratories Record* **12** (Mar 1934) 203–208.
- [46] R. C. Miner: Notes on ERPI's Stereophonic Sound Picture System. *International Projectionist* (Nov 1937) 22–23.
- [47] R. C. Miner: Diphonic Loudspeaker for Mirrophonic Sound Systems. *Bell Laboratories Record* **16** (Oct 1937) 53–55.