

**Xo order 3 Butterworth,
1 kHz (-3.0 dB)**

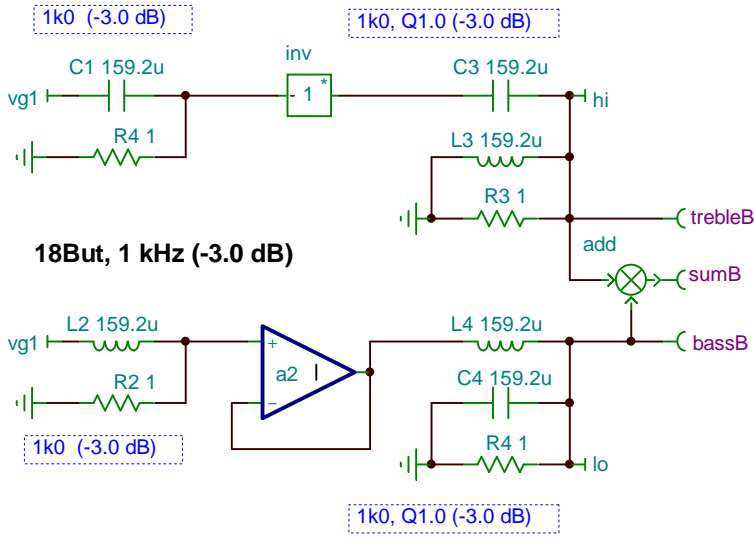

**Xo order 4 Linkwitz-Riley,
1 kHz (-6.0 dB)**

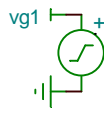

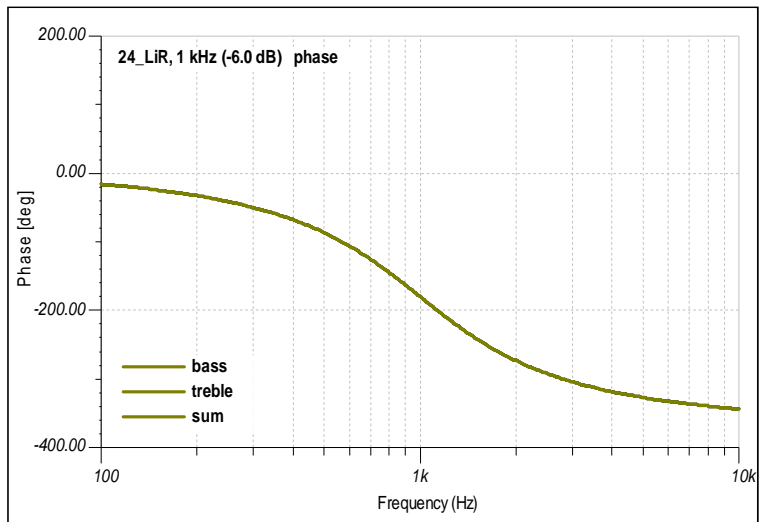
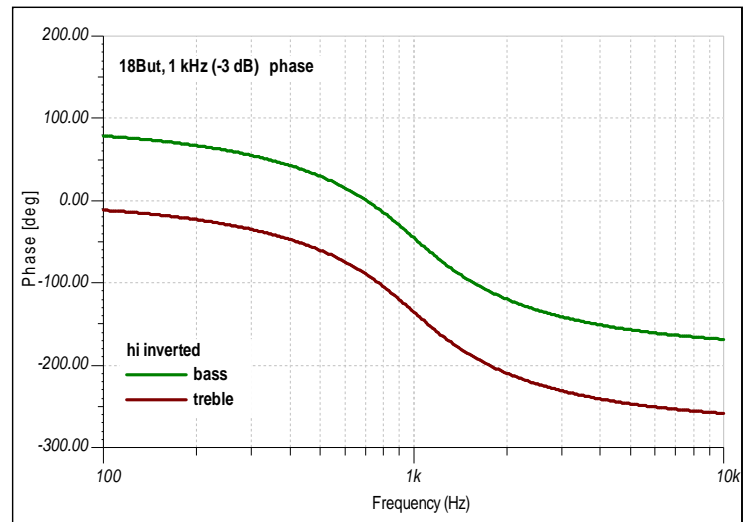
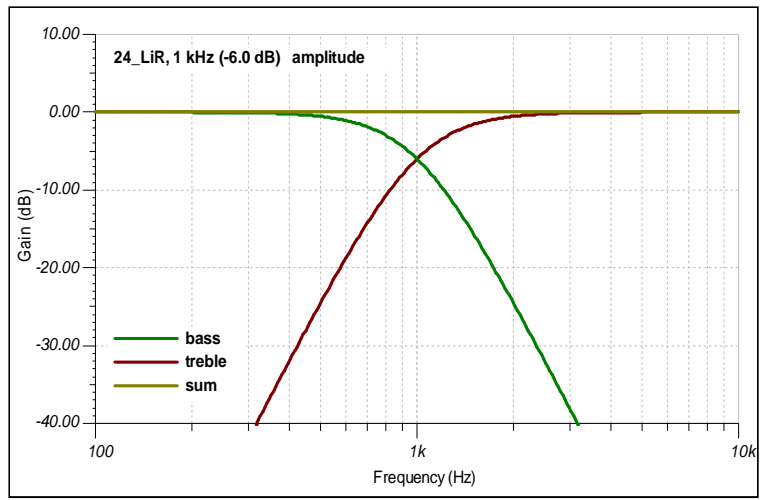
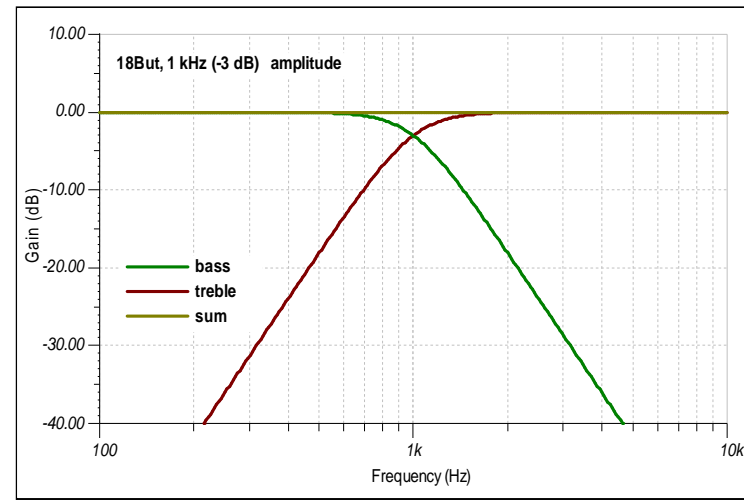
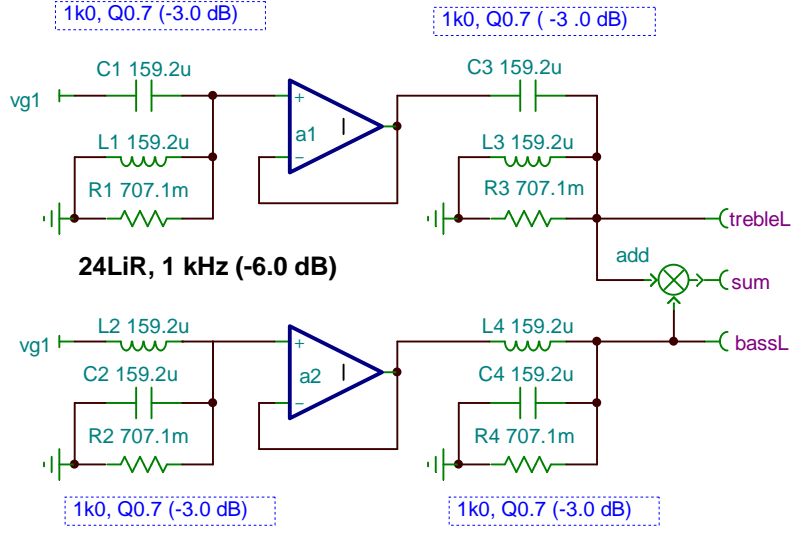
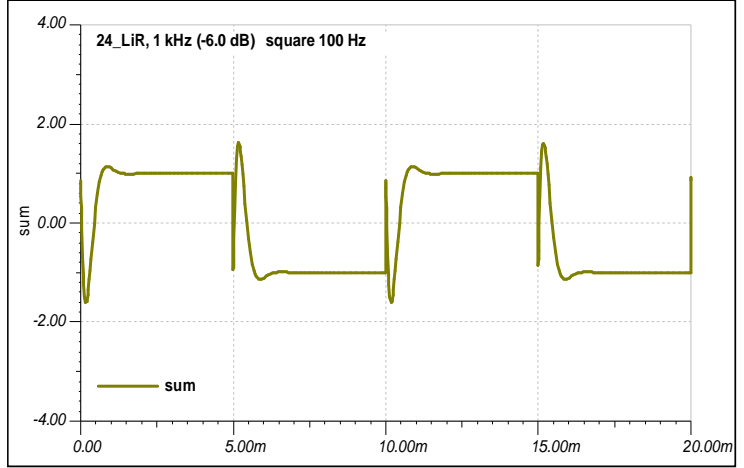
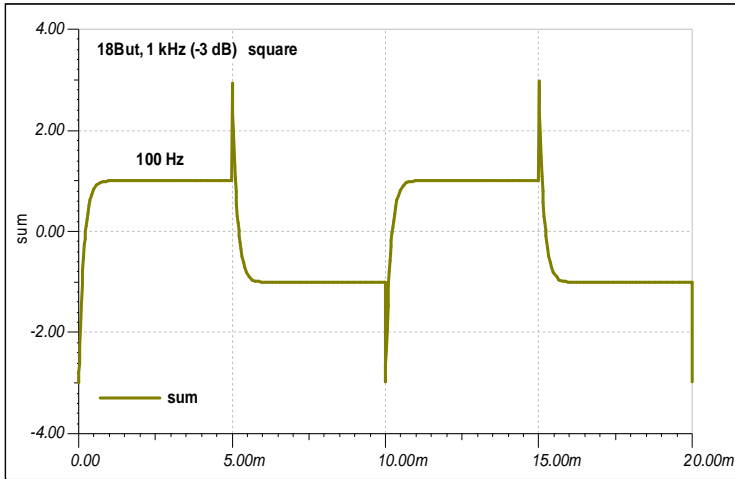
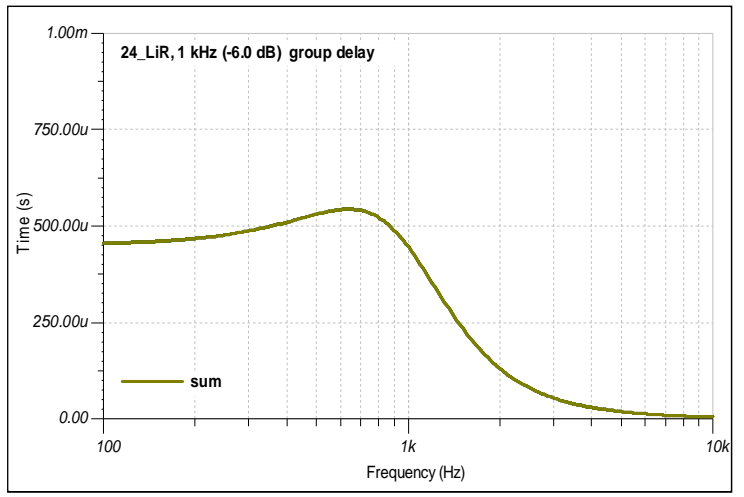
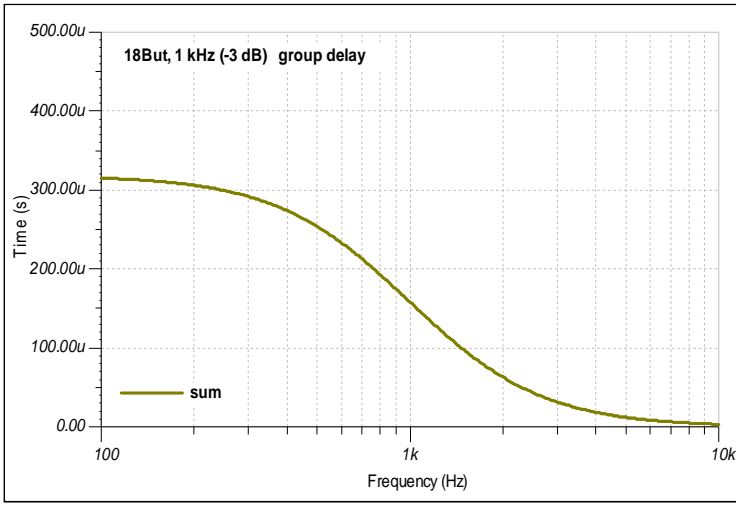

\$\$\$