

The Daline

A decoupled anti-resonant line loudspeaker

by Robert Fris

THE basic parameters affecting loudspeakers intended for a domestic environment may be considered under three headings: (1) cabinet, its mounting position, size, and the resulting height of sound image; (2) performance, in terms of maximum acoustic output, power handling capacity, efficiency, frequency range, deviations in amplitude response, distortion, and transient response; and (3) cost.

The size of the cabinet determines the low frequency performance almost directly, the upper frequency range being unaffected. The first consideration, then, is to optimise the low frequency performance, and the performance over the rest of the audio range can be determined at a later stage depending on the initial results.

An analysis of the bass loading principles revealed that the tuned pipe appeared to offer the best low frequency performance potential. The manner in which it is utilised is by exploiting the fundamental 'anti-resonance'.

This occurs in an open pipe at the frequency whose acoustic wavelength is four times the length of the pipe, i.e. $l = \lambda/4$. The drive-unit is coupled directly to one end of the pipe, as shown in fig. 1. Taking the instant when the cone is at its peak negative displacement, a compression will be expelled into the pipe and transmitted along it to reach the open end one quarter of a cycle later. Meanwhile, the cone has continued to its position of zero displacement. The compression is expelled into the free air, sending a rarefaction back along the pipe to the cone. On reaching the cone, another quarter of a cycle later, it finds the cone at its peak positive displacement and applies a sucking force to it, tending to reduce its amplitude.

This action, which is of course continuous, results in a lower cone amplitude for a given input power and frequency, and augmented radiation from the open pipe.

An analogy is that of the quarter-wave stub, which, when short-circuited, presents a theoretical open circuit to the generator. In practice, the air is not a short-circuit and neither is the pipe lossless. The air presents

a low impedance consisting of radiation resistance and air mass close to the radiator.

The expelled pressure wave from the pipe proceeds into this terminating impedance in much the same way as current does from a transmission line, producing power dissipation, and hence radiation, in the resistive element.

The control over the cone amplitude is an important factor, as a significant improvement in low frequency power handling capacity and/or distortion can be obtained.

A drive-unit mounted on a true infinite

FIG. 1 $\frac{1}{4}$ WAVE PIPE ($l = \lambda/4$)

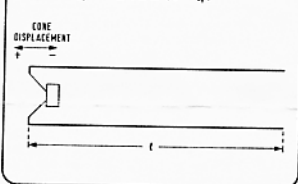

baffle or in a sealed enclosure, so that radiation from the cone is not augmented acoustically, will exhibit, for a fixed power input, a varying amplitude with frequency. At frequencies above that whose wavelength is equal to the cone circumference, the cone is loaded by the radiation resistance which is constant. Below that frequency, the cone is loaded by the mass of air immediately in front of and behind it, the reactance of which varies with frequency. It is over this range that the cone radiates as a point source with a theoretically hemi-spherical radiation pattern, and cone velocity inversely proportional to the frequency.

As the frequency at which the turnover between mass and resistive loading is dependent on the size (and shape) of the cone—the optimum shape being circular—a different amplitude will occur at a given frequency for differing cone sizes. In addition,

the radiation resistance is proportional to the square of the cone area, so that if two different size drive units are compared, the cone amplitude curves will appear as shown in fig. 2. Strictly, these curves and those in fig. 3 show cone velocity, not amplitude; but they have been rationalised to give an apparently constant amplitude over the resistively loaded HF range (whose amplitude is really already inversely proportional to frequency), so that the effect of mass loading (giving an inverse square-law to amplitude) is more evident.

It can be seen that the smaller cone always has a higher amplitude for a given frequency and input power, putting heavier limitations on power handling capacity.

The second factor relating to cone size is the efficiency, which is proportional to the square of the cone area, but also inversely proportional to the cone mass. However, the mass is, in practice, more or less proportional to the area, with the result that the efficiency becomes approximately proportional to the area.

For the sake of maximum radiated output, the cone should be as large as possible; but, neglecting the problems due to cone support, break-up modes, etc, the mass would be so high as to seriously disable high frequency output and, more important, transient response. In contradiction, to maintain the transient response at an acceptable value, the cone should be as light and, therefore, as small as possible.

In some loudspeakers, incidentally, to obtain a reasonably efficient low frequency performance, a very large cone 'super' bass unit is employed, the use of which is supported by the argument that a good transient performance at low frequencies is not necessary, the harmonics of the transient being reproduced by the higher frequency drive units. Two arguments that arise from this are that the bulk of the energy contained in a transient is at the fundamental (try standing in front of a pedal drum), and that the amplifier is not fully able to stop the ensuing resonance. Such an acoustic hammer is maybe ideal for juke boxes (listen to the bass!) but is a poor attempt at true reproduction.

The first compromise, then, is with cone size, one approach to its resolution being to employ as small a bass cone as possible

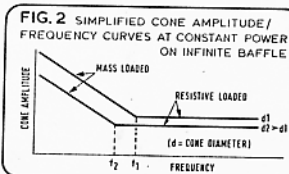

commensurate with sufficiently high available output power at low distortion. For high power systems it is preferable to use several small bass units rather than one large unit, so that the mass per motor is minimised even though the total moving mass is as high. However, as will be seen later, one surprisingly small bass unit, when acoustically loaded to best advantage, can perform better

The Daline

at low frequencies than a large one not so loaded.

Referring to fig. 2, it can be seen that, in the mass-loaded region maximum input power before overload is dependent upon the frequency, such that a compromise exists between input power and low frequency extension, the condition being progressively worse for smaller bass units.

If a small bass unit is loaded by a tuned pipe, a considerable improvement can be effected by impeding the cone amplitude over the range at which it would be mechanically overloaded at high signal levels. By applying a suitable choice and quantity of damping materials, the cone 'amplitude' curve can be doctored to appear as shown in fig. 3.

As the 'amplitude' is constant over the range f_1 to f_2 , the frequency at which mechanical limiting first occurs is shifted downward by the same amount. The level portion intersects the unmodified curve of the larger unit, so, at and below the intersection frequency, the effective radiating area equals and then exceeds the area of the larger cone.

This is achieved neither at the expense of transient response, as no mass is added to the cone, nor low frequency output, as this is radiated from the pipe. As the impedance presented to the cone is constant over this range, it must follow that the pipe radiates with an increasing amplitude to compensate for the changing air impedance. This can be observed when holding a piece of light-weight paper in front of the pipe's open end.

Ringling in the pipe does not occur at these frequencies because the anti-resonance is by nature restrictive of cone motion and therefore limits its own source of energy, but above this range the pipe enters into a series of harmonic resonances, all of which should be suppressed.

The transmission line loudspeaker achieves this with a taper of the pipe and very careful dense packing of absorbent materials. The loading on the cone above the anti-resonance is nearly constant and resistive, the value of which is high. The efficiency is low, requiring a large bass unit to gain what is lost.

Unfortunately, problems associated with cone mass, cone break-up, overall size and cost arise; on the other hand, coloration due to internal reflections is negligible, as rear radiation from the cone is absorbed in the pipe except at the lowest frequencies.

However, the extra output emitted from the pipe can create a rather bass-heavy impression when the loudspeaker is placed against a wall, and extremely so when placed in a corner. The TLS is ideal for studio and exterior use where free-field positioning makes the large size and low frequency output unobtrusive. A few compact TLS models are available but these have rather high cut-off frequencies giving little improvement over sealed enclosures of the same size.

Alternative to absorbing the mid-range radiation in a heavily damped pipe, the pipe may be decoupled from the drive-unit above the anti-resonance range. A low-pass filter inserted between the bass unit and the pipe

would take the form of a cavity as shown in fig. 4. (Such an enclosure would behave like a Helmholtz resonator or reflex system if the pipe were short compared with the wavelength.) The frequency of turnover, at which the acoustic capacitance of the cavity begins to shunt the acoustic resistance of the pipe, will be dependent upon the size of the cavity and of the orifice. At frequencies above the anti-resonance of the pipe, the cavity presents a low impedance to the cone, so the rear radiation may be contained in and absorbed by the cavity. As the frequency is lowered, the cone is progressively coupled to the pipe. If the cavity's Helmholtz type resonance and pipe's anti-resonance are coincident the drive-unit will be mass loaded (but stiffness constrained) by the cavity on the upper side of its resonance and mass loaded by the pipe on the lower side of its anti-resonance.

Extra bass extension may be obtained by tuning the pipe a little below the cavity, in which case, between the two centre frequencies the mass elements add and the stiffness components cancel, maintaining consistent mass loading. Care must be exercised not to allow the cavity resonance to coincide or

FIG. 3 BASIC CURVES COMPARING SMALL PIPE-LOADED BASS UNIT WITH BAFFLE MOUNTED LARGER UNIT

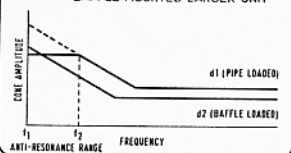

overlap the pipe fundamental resonance, so a limit must be placed on the maximum ratio of the two frequencies of about $1\frac{1}{2}:1$.

The cavity and pipe are damped by the inclusion of absorbent materials, to lower the Q factor, broaden the bandwidth, and slow the speed of sound within them to gain apparent volume. Separating the centre frequencies causes an electrical impedance rise in the bass unit as the resistive loading on the cone is reduced at the cavity resonance, but so long as this is not excessive, as would be caused by insufficient cavity damping, no disturbing effects should occur.

The main advantage with this, the Daline system (Decoupled Anti-resonant Line) is that the midrange efficiency can be better matched to the low frequency efficiency when concentrated in $\frac{1}{4}$ -sphere of space. The midrange efficiency is higher than an absorbent line would provide, and because of the ability to vary the parameters of the pipe without upsetting midrange performance, a good degree of control is possible.

A mild negative taper has been introduced to the pipe to aid the elimination of harmonic resonances and broaden the response of the anti-resonance. In such a lightly damped pipe the depth of taper must be limited to prevent reflections from the pipe walls. A negative taper with a $1\frac{1}{2}:1$ reduction ratio in area has been found satisfactory, but it is yet to be established what is the optimum. The

minimum area of pipe is equal to the cone area, but it could probably be reduced to about half the value without introducing any noticeably detrimental effects.

The Daline system can be applied to any size bass unit, but offers the best results from units of about $3\frac{1}{2}$ to 5 ins. cone diameter, because of the low mass of such cones. Over the anti-resonance range the effective radiating area increases by up to a factor of five or so. This means that a 4 in. cone will have a low frequency amplitude similar to that of a baffle loaded 10in. cone for the same input power. Doppler distortion problems at this frequency are then no worse than for the larger unit. The size of a sealed enclosure for the larger unit to radiate such low frequencies would be enormous, whereas the Daline model is quite small, occupying no more than 1-lcu. ft. (internal).

The cut-off frequency is determined by the combination of drive-unit parameters and cabinet dimensions, so the designer is not limited to one cut-off frequency for a particular drive-unit, but is free to establish whatever size cut-off compromise he wishes. The best compromise appears to place the cut-off frequency around 0.7 of the frequency of the drive unit's free-air resonance. For a full-range system this means that a drive unit with a free-air resonance of 30 Hz is required to obtain an output down to 20 Hz. The majority of large loudspeakers have a cut-off at about 40 or 50 Hz, and this is plainly evident when listening to a pipe organ or bass drum; but some compromise must be accepted with any speaker of practical dimensions.

Several loudspeaker systems have been constructed on the Daline principle and the one that best exemplifies the advantages of the system is described below. It employs

FIG. 4 ADDING A LOW-PASS FILTER

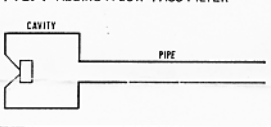

one twin-cone drive-unit of 6in. diameter and 55 Hz free air resonance, and covers the range from 35 Hz upwards. The quality is certainly not high in the treble region, but is perfectly adequate when one considers that a pair of these costs under £20 to build (at the time of writing).

The treble range is reproduced rather enthusiastically by the centre cone, and it has been found that a worthwhile improvement can be effected by inserting a piece of 1in. thick sponge rubber in the centre of it. The sponge should be cut into a disc to fit easily inside the cone, leaving a 1in. lip of cone protruding, and fixed in with a little light glue. Although this appears to be a somewhat hit-and-miss approach, a substantial improvement can be made and further experimenting can be undertaken by the constructor if desired. The overall efficiency when modified is about $1\frac{1}{2}\%$, so with a power handling capacity suitable for a 15 watt-per-channel amplifier, reasonable sound levels are

The Daline

obtainable in a moderate size room.

Figs. 5, 6 and 7 show constructional details. Complete air-tightness is imperative; if doubts arise over the condition of any joint in this respect, it must be sealed with extra glue or sealing material. Panels should be cut to the sizes indicated in the Materials List; it is preferable to have the timber machine-sawn to ensure accuracy and hence trouble-free assembly. Plywood is preferred to chipboard for cleanliness of sawn edges, strength and long-term stability. It is also more expensive. The following is a recommended building sequence.

(1) Cut out and drill holes in **FRONT**. The drive unit hole is arranged to taper out from 5/16 in. on the inside to 6/16 in. on the outside of the panel to prevent a column of air being formed in front of the cone. Care must be taken, however, not to interfere with the mounting bolt holes. The best order of approach is to cut out the main hole with parallel edges, then drill the mounting bolt holes, followed by chamfering of the sections of the main hole between the mounting bolt holes, avoiding the parts of the edge immediately adjacent to them.

(2) Glue and pin **TOP, BOTTOM** and **SIDES**, in that order, to the **FRONT**. Ensure that all panels are square to each other when pinning.

(3) Leave while glue dries.

(4) Glue in **PARTITION** ensuring that it is square with **FRONT** and **SIDES**.

(5) Glue in **SUPPORTS** and apply dabs of glue to the surfaces of the front section of the pipe.

(6) Insert 1oz. of **TERYLENE WOOL**, well teased out, in the front section of the pipe and ensure that it is in contact with the glue spots.

(7) Glue in **SECTION**, ensuring that it is glued all along the edges in contact with the **SIDES** and **PARTITION**.

(8) Leave to set.

(9) Glue the **BATTENS** in position around the **TOP, BOTTOM** and **SIDES**.

(10) Glue **BRACING** ONTO **BACK**.

(11) Leave to set.

(12) Insert 1oz. of **TERYLENE WOOL**, well teased out, as before, in the rear section of the pipe, held in by dabs of glue.

(13) Mount the drive unit onto the **FRONT** and wire up to the connector on the **BACK**, taking care to connect the positive tag of the drive-unit to the positive terminal of the connector.

(14) Tease out and insert 1oz of **TERYLENE WOOL** in the cavity and glue the **SPONGE SHEET** onto the inside of the **BACK** so that it covers the **BRACING** but leaves a 1 in. gap all round the edge of the panel in order for it not to interfere with the **BATTENS**.

(15) Screw **BACK** ONTO **BATTENS** with a strip of **Bostik SEALING STRIP** in between.

(16) Connect the loudspeaker to an amplifier fed by an oscillator set at 40Hz, or by hum induced by a finger applied to a sensitive input. Listen around the joints of the loudspeaker (still with the finger on the amplifier!) to check that no whistling or chuffing noises are present. The volume

FIG. 5 EXPLODED VIEW OF THE DALINE

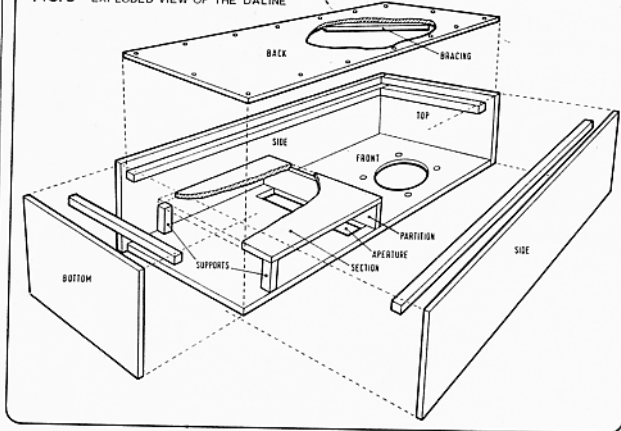

should be as high as possible without overloading the amplifier or loudspeaker. If extraneous noises are heard, a leak must exist and should be rectified by applying more glue or sealing material.

Finally, hold a piece of light-weight paper over the aperture and firmly against the top edge of it. Check that the paper flaps vigorously at high volume of the test tone.

If it doesn't, an internal leak must exist (i.e. between **PARTITION** and **SIDES**) or a gross over-estimation of damping material quantity has been made.

The speaker is now ready for final embellishments and operation.

Like the T.L.S., the Daline system exploits the anti-resonance of the tuned pipe to the same advantage, permitting truer reproduction

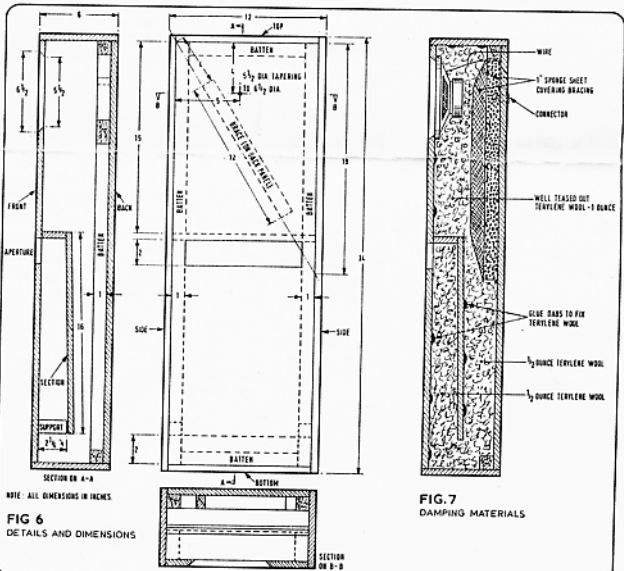
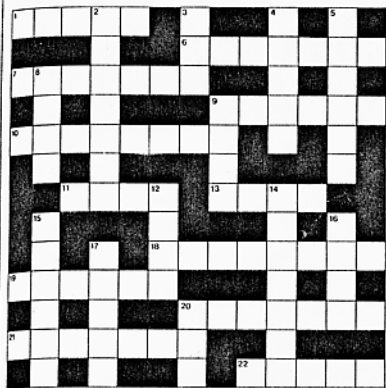

FIG. 6
DETAILS AND DIMENSIONS

FIG. 7
DAMPING MATERIALS

Audio Musical Crossword

devised by Maurice Taggart



CLUES ACROSS

- 1 & 11 Sounds fine for a hi-fi bonanza. (5-4)
- 6 A form of dieting imposed on tape recording enthusiasts. (7)
- 7 Mixed stereo loses a point, embracing total abstinence to draw together. (7)
- 9 Little Sidney, Violet and I get together and arrange the strings for spatial effect. (6)
- 10 & 21 Opening Walton number; dragon music, possibly? (8-7)
- 11 See 1.
- 13 Valve or Metro in transatlantic guise. (4)
- 18 In some dis-array, Dido and I follow the vehicle for a microphone. (8)
- 19 Suk and Des get together to present an 18th-19th century Czech composer/pianist. (6)
- 20 Popular Hungarian-born conductor, now gone. (7)
- 21 See 10.
- 22 R-K derived this from pleasant arias. (5)

CLUES DOWN

- 2 It's difficult to move when Ian has muddled rite. (7)
- 3 Roaring 17th-18th century Italian composer, mainly of 'comic' operas. (8)
- 4 Vesta goes about to provide musical framework. (5)
- 5 Workers' organisation gets a point for all playing together. (6)
- 8 & 16 Audio fan objects strongly to this arrangement of his tapes. (4-4)
- 9 Cambridge musicologist currently appearing in Camden Town hall. (4)
- 12 Seaside music, with a heavy rhythm presumably. (4)
- 14 British composer who is non-alcoholic in the midst of brief somehow. (7)
- 15 Rush around and get the little advertisement in for Amy. (6)
- 16 See 8.
- 17 Little Pamela is mixed up with the loudspeaker initially, producing biblical music. (5)
- 20 You may press it or use it for a tonic. (3)

A £2 record token will be awarded to each of the first five correct solutions picked from those which arrive before November 5th.

The Daline

of any low frequency signal (including rumble) without the notorious boom that characterises large sealed enclosures and poorly designed reflex systems. But, unlike the TLS, the Daline allows a small bass unit to be employed in a smaller cabinet for a

similar efficiency and low frequency cut-off, concurrent with a significant improvement in transient response resulting from the lower cone mass, and considerable reduction in complexity and cost. Two useful products of this are that the smaller bass unit may be operated to a higher frequency, reducing the number of drive units required for a high quality system, and the subsequent cost saving, not only from the smaller bass unit and cabinet, but from the lower number of drive units and crossover components.

Although the system design parameters are not critical, it is not necessarily possible to substitute the bass unit for another type in a particular cabinet, so it is important to use the specified drive unit in the model described. Two units may have the same physical dimensions and even chassis construction, but unless they have the same model number they can possess quite different dynamic parameters, so it is not a safe bet to fit any drive unit of 6 1/2 in. diameter.

The Daline system is not limited to use with any particular size of drive unit, but offers best results, for the reasons given earlier, with as small a bass unit as possible, the optimum so far established being 5 in., giving reproduction down to below 30Hz from a cabinet the same size as the one described (but with a completely different internal construction).

The whole aim of loudspeaker design is to produce a system that renders reproduction as close to perfection as possible, and as development continues this aim is being gradually approached. With The Daline system the imperfections are at least contained in a smaller box.

MATERIALS FOR TWO CABINETS

All dimensions in inches, unless otherwise stated.

- | | | |
|---|----------------|--|
| 4 off 34 x 6 x 1/2 plywood or chipboard | SIDES | |
| 4 off 11 x 6 x 1/2 " | TOP and BOTTOM | |
| 4 off 11 x 33 x 1/2 " | FRONT and BACK | |
| 2 off 11 x 2 x 1/2 " | PARTITION | |
| 2 off 11 x 16 x 1/2 " | SECTION | |
| 4 off 33 x 1 x 1 deal | BATTENS | } 3 off 8 feet, with
SUPPORTS to
BRACING |
| 4 off 9 1/2 x 1 x 1 " | BATTENS | |
| 4 off 2 1/2 x 1 x 1 " | SUPPORTS | |
| 2 off 12 x 1 x 1 " | BRACING | |

- 1 box 1 inch Panel Pins
- 1 pint Evo Resin W or ICI Dufix glue
- 30 off 1 1/2 inch no. 6 countersunk steel screws
- 1 pack Bostik Sealing Strip
- 8 off 1 1/2 inch 2BA Bolts, Nuts and Washers
- 4 ounces Terylene Wool (available from Pet shops for fish tank water filters)
- 2 off 18" x 9" x 1" Closed Cell Sponge Sheet
- 2 off RS Components 6 1/2" Longthrow loudspeakers
- Offcut of 3/4" Closed Cell Sponge Sheet, for h.f. cone modification, if desired

Note: RS Components do not supply direct to the public, but the drive units can be ordered through an appropriate retailer who can obtain them in a few days.

cone bass units to secure a low cut-off frequency at the expense of the inability of the cone to respond suddenly to change in position. The bulk of the power of a transient is at the fundamental frequency—from a pedal or orchestral bass drum at something like 10 to 30 Hz. This is considered sub-audio by many, mainly, it seems, for convenience, but it is the power at these frequencies that carries the "weight" and character of such instruments.

All loudspeakers with a cut-off frequency determined by a resonance much above 20 Hz cannot, even by any twiddling of the bass control, properly reproduce such instruments. The sudden application of, say, a 20 Hz signal to a loudspeaker with a fundamental resonance at 60 Hz has the salient effect of exciting the resonance of the system. This will take a finite time to build up, because energy is absorbed into the resonating components, the cone mass and the suspension and cabinet air stiffnesses, at an exponential rate. And an even longer time will elapse during the decay while the energy is dissipated into the radiation resistance and frictional losses.

The applied transient is then disintegrated into essentially two parts; the result of exciting the system resonance and the reproduction of some harmonics by the midrange cone. The result is that all signals of lower frequency than the resonance, which in music are transient, are stripped of their attack and character by emerging from the loudspeaker as that (literally) monotonous "boom" that is often described as "full rich bass".

In addition, the rate of cut-off of sealed enclosures is 12 dB per octave, and of vented enclosures, reflex or ABR systems is 18 dB per octave, so any tone that is applied continuously below the resonance frequency will have its harmonics emphasised accordingly. If, as is usual, the bass unit distorts at a high volume, the harmonic generation will be added to. So the fundamental is as good as lost. It is fair to say that these systems will not radiate any frequency appreciably below the system resonance.

The stated cut-off frequency of these Daine versions is 20 Hz, which is the lowest frequency that can be reproduced at full power. The cone will reproduce frequencies down to below 10 Hz but with gradually diminishing assistance from the pipe. This is because the pipe, by presenting a mass load to the cone below the peak of the anti-resonance, increases the total moving mass, thus "pulling down" the cone resonance to between 5 and 10 Hz. High powers at these frequencies will overload the drive unit because, in effect, it is unloaded acoustically.

When the resonance of a loudspeaker system is eliminated, the transient response at low frequencies is limited only by the size of the magnet and total moving mass of the bass unit. Consequently, the larger the magnet, to produce a greater motive force to the cone, and the smaller, hence lighter, the cone, the quicker it will react to sudden change, or attack, giving a better transient response.

The B110 uses a flux density in its gap greater than that used in many 12 in. bass

units, and it is obvious that the cone is considerably lighter. So the B110 has far better transient capabilities than its larger colleagues.

As well as having a low free air resonance (30 Hz), the B110 is quite happy as a midrange unit up to about 3 kHz. This eliminates the need for a third or fourth drive unit where, in high quality systems, it is often found that the bass unit cannot cope above about 300 Hz.

The power handling/efficiency product enables realistic sound levels to be obtained. 97 dB s.p.l. was registered on a sound level meter held four metres away from one loudspeaker reproducing enthusiastic classical music. The peak of the transients must therefore have been several decibels in excess of the indicated figure. Thus one can safely gather that the peaks were well over 100 dB, which level seems to be the criterion for "concert hall loudness"—and never mind the neighbours.

The power amplifier used delivered 50 watts per channel into 8 ohms. This is the highest rating that the loudspeakers will tolerate under the variety of normal use. Nevertheless, the speakers are adequately efficient to make plenty of noise fed by a 15 watts per channel amplifier in a softly furnished 25 x 14 ft. living room.

The input impedance does not fall below 8 ohms at any frequency. Amplifiers designed

the T15 reproduces the 1 kHz to 3 kHz band instead of the B110 and the Coles 400G is better than the T27, the difference in transient response throughout the audio range is quite noticeable when listening to music from a high quality source.

Rumble is not normally associated with loudspeakers. Unfortunately, the penalty for having a low cut-off frequency manifests itself in the better reproduction of rumble. The Daine will reproduce all but the bottom frequencies without much effort. But, at high volume, these lower frequencies will cause large cone displacements. Apart from being good exercise for the cone suspension, it does not help the output capabilities of the bass unit, since there is not much "room" left for bass frequencies to move the cone further. Not only does this occur in the loudspeaker, it hinders the output stages of the amplifier for the same reason, and causes unnecessary power dissipation anyway. The simple expedient for curing this trouble, if it occurs, is to make use of the rumble filter.

Because the acoustic system requires little space, the cabinet is sufficiently small to raise the question: should it be arranged as bookshelf or free standing? As a bookshelf cabinet, it could be rather large, but, on the floor, considerable advantage can be gained because it would be quite unobtrusive. Most Loudspeakers, whether they are intended to

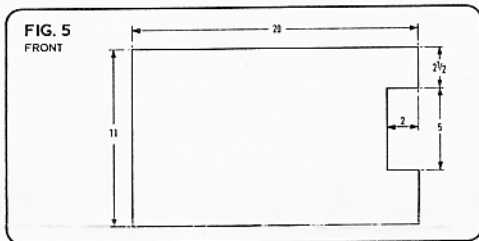

for 8 ohms loading minimum will not be embarrassed by really low impedances at low frequencies—a frequently used expedient for producing an apparently better bass response.

The frequency ranges of the two versions are very much the same. In the three unit version, the crossover frequencies (1.2 kHz and 7 kHz) were selected to exploit what was considered the best part of each drive unit's range in order to maintain a wide dispersion angle without the need for "doctoring". The two unit version had to accept some compromise in this respect since the crossover frequency is at 3 kHz and it was found that the B110 suffers a rise in the frequency response above 1 kHz. Also, the T27 output was found to die a little earlier than hoped. A step response filter in the bass crossover circuit eliminates the hardness of sound caused by the hump, and a high pass filter in the tweeter circuit boosts the frequencies above 10 kHz to sweeten up the top end.

The smoothness of the three-unit version is readily apparent from side-by-side comparison with the two unit version. Since

or not, seem to end up on the floor anyway. Quite often behind the settee!

Free standing the cabinet became, with an elongated appearance (34½ in. tall) to enable the drive units to be mounted at listener's ear level without the need for elevating the cabinet. As a result, the floor area consumed is a minimal 12 x 6 in. Consequently four for quadraphony is not such a frightening thought.

For best performance, the loudspeakers should be placed flat against a wall—no need to angle them towards each other as the drive units are practically omnidirectional over a fairly large lateral angle. Preferably not in or across a corner since corner positioning strengthens room resonances which swamp the good bass performance of the loudspeaker. Placing the cabinets a foot or two away from the corners (but still against one wall) is satisfactory.

The positioning is not critical, only that the loudspeakers were designed to give the correct bass response when placed against a wall. The good transient response makes the various resonances of a room quite noticeable,

it is probably best to experiment with different loudspeaker positions before settling on a final layout.

The three unit version is the highest quality Daline loudspeaker developed so far, with the two unit version following as a close second. In both cases, not only do they assume much less space than conventional loudspeakers, the improvements in low frequency performance that result from the Daline system are certainly not insignificant.

Construction

The basic cabinets should be constructed with either $\frac{1}{8}$ in. chipboard or the same thickness of plywood. Exterior ply is best and consequently the most expensive, unless a tight budget dictates otherwise, in which case exterior ply since it saws and drills cleanly whereas chipboard and, to a lesser extent, interior ply tend to crumble, especially at the corners. There appears to be no subjective difference in performance when comparing loudspeakers built of these materials. The important aspect is that the cabinets must be built with no leaks externally or internally. Even a slight leak can have a devastating effect on the performance. External leaks can be impossible to rectify, simply because they would be inaccessible. Frightening this may seem, but there is really no need for worry. Several cabinets have been built to date by various amateurs with no trouble having been experienced by any of them—unless they are too proud to admit it! So long as the assembly instructions are followed no problems should arise.

The cabinet joints are just glued, with wood pins inserted to hold them together while the glue dries. Batters are not required on these joints since the glues specified have more than adequate strength for the purpose.

To ensure maximum rigidity and tightness, the only removable panel is the baffle. Assembly is started around the back panel and the damping materials are inserted during assembly.

Styling of the cabinet is, of course, the prerogative of the constructor. So long as care is taken over the choice of grille cloth cheap ones mask the treble and impede the movement in front of the aperture) and no large projections are introduced, any front panel styling is acceptable.

In order to minimise the effect on the stereo image of interference patterns that arise at the crossover frequencies when two drive units are radiating together, the drive units are mounted so that the horizontal shift at crossover is minimal (zero in the two unit version) without undue vertical spread of the sound source.

The terminals on the models so far built are high up on the back panel. Apart from being helpful when the speakers are being moved, it enables the internal wiring to be kept minimal.

The instructions for assembling the loudspeakers follow. They may appear rather formidable, but they are intended to be as comprehensive as possible so that no problems should arise. We all suffer a tendency to ignore instructions and have a habit of sorting it out alone at times, which in

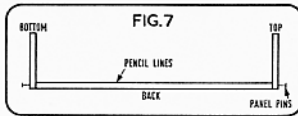
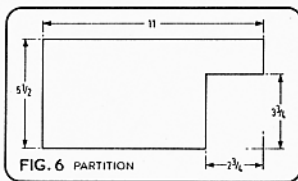

this case, you are just as welcome to do. But be it on your own head!

Crossover Assembly

The crossover circuits are shown in fig. 8. The components are mounted on the wiring boards according to the layouts in fig. 9. The lead-out wires are used to form the wiring on the underside of the board.

The three unit crossover is mounted on the baffle by a 2BA stud which also serves to mount three power resistors on the board. Connections to these resistors are taken by wires from the points indicated on the board layout to the resistor terminals.

The two unit crossover is more

conventional as the resistors are all cylindrical types and the board is screwed onto the baffle with spacers between to keep the wiring clear of the baffle.

None of the capacitors specified is electrolytic, since these are prone to introducing distortion and are unpredictable in quality. Polyester capacitors are used throughout as these are good quality components. Do not substitute any other type of capacitor.

Likewise, the coils have been carefully selected since the quality from different sources varies enormously. The supplier named in the materials list stocks well bonded adequately sized coils which do not appear to saturate at high power levels. Steer clear of coils held down by sticky tape only.

So long as they are adequately rated, alternative resistors may be used, but do not change the values. The crossover filters were designed to be loaded by the total load presented to them by the attenuating resistors and voice coil impedances. If these loads are changed, the filters could resonate or turn-over at a different frequency. (These matching impedances are not 8 ohms.)

Cabinet Assembly: Figs. 1 and 2

Have all the panels machine sawn for accuracy. Check that the SECTIONS for each cabinet are all exactly the same width and plane them down if necessary.

A mirror image pair for stereo is made just by cutting one baffle in reverse. Do not attempt to reverse the construction of one cabinet.

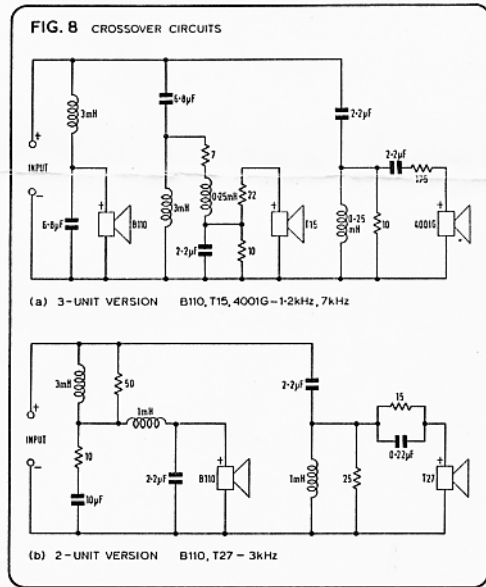

1 Draw pencil lines Nos. 1 to 4 on each BACK. See fig. 3.

2 Compile two stacks of panels, one for each cabinet, ensuring that all the SECTIONS in each stack are matched.

3 Using the appropriate drawing in fig. 4 for the two or three unit version, mark up and cut out the holes in the BAFFLES. Cut out the recesses for the B110 and T27 in the front of the baffle and for the T15 in the rear. The recess for the B110 has been shown square, which is easier to cut than the shape of the B110 mounting flange, which should really be followed.

4 Cut out the areas from the FRONTS and PARTITIONS shown in figs. 5 and 6.

5 Cut out the hole in the BACKS for the loudspeaker connector chosen. DIN sockets were used in the models photographed. The position is not important but is best where it is accessible from the cavity and will not interfere with the BRACE.

6 Apply glue to the short edge furthest from the pencil lines of one BACK and lay the panel, pencil lines up, on a flat clean surface.

7 Fix the TOP to the glued edge of BACK, as shown below. Ensure that the TOP is square to the BACK and that the edges are flush, then drive two or three pins through the TOP into the edge of the BACK to hold the joint.

8 Apply glue to the other short edge of the BACK and repeat 7 for the BOTTOM.

9 Apply glue along one long edge of the BACK, continuing along the adjacent edges of the TOP and BOTTOM. Mount one SIDE onto the glued edges. Ensure that the panels are all square to one another and that the surfaces and edges are flush where they meet. Drive pins through the SIDE into the other three panels.

10 Repeat 9 for the other side.

11 Repeat 6 to 10 for the second cabinet to allow the glue to dry on the first one.

12 Return to cabinet No. 1. The PARTITION is installed NEXT. To ensure a good joint between the PARTITION and FRONT, since this joint is not also be airtight, measure off the distance between the PARTITION and the BOTTOM with the length of the FRONT. Lay the FRONT in the part assembled box as though it were being fitted, but because there is no support for it lay one long edge on the BACK and rest the other on the top edge of one SIDE, so that the FRONT is at an angle with the BACK. The PARTITION can be installed by pressing it firmly against the top edge of the FRONT. Apply glue to the two short edges and the interrupted long edge of the PARTITION and install it as detailed above with the cut-out to the rear and right of the cabinet—see fig. 2. Check that it is square to the SIDES and BACK and insert pins through the SIDES into the edges of the PARTITION. Remove the FRONT, taking care not to disturb the PARTITION.

13 Apply glue to one surface of the BRACE and press the BRACE onto the BACK to one side of a diagonal across the cavity. It does not matter which diagonal, so long as it does not interfere with the connector.

14 Apply glue to one surface of one

LONG BATTEN. Fix the BATTEN to the inside surface of one SIDE so that a $\frac{1}{4}$ in. gap is left between the batten and the front edge of the SIDE.

15 Repeat for the other LONG BATTEN and the other side of the cabinet.

16 Apply glue to one surface of each SHORT BATTEN and fix the battens to the other two walls of the cavity to form a continuous ledge around the cavity.

The four SECTIONS should now be installed as shown in fig. 2, as follows.

17 Liberally apply glue to one long and one short edge of SECTION 1. Mount the SECTION with its glued long edge along the BACK and the glued short edge in contact with the PARTITION. The surface of the SECTION facing the right hand side of the cabinet must be against pencil line No. 1. Ensure that the SECTION is perpendicular to the BACK.

18 Apply glue to one long and one short edge of SECTION 2. Mount the SECTION with the side facing SECTION 1 along line No. 2 and the glued short edge in contact with the BOTTOM. Ensure that the SECTION is perpendicular to the BACK.

19 Liberally apply glue to one long and two short edges of SECTION 3. Mount the SECTION with the side facing the PARTITION in contact with line No. 3 and one glued edge butted against SECTION 1.

Ensure that the SECTION is perpendicular to the BACK and that SECTION 1 has not been disturbed.

20 Similarly apply glue to one long edge only of SECTION 4. Mount the SECTION onto the BACK so that one end of the side facing SECTION 2 is in contact with the remaining glued edge of SECTION 3 and the same side runs along pencil line No. 4. Ensure that the SECTION is perpendicular to the BACK.

21 Finally, check that all the SECTIONS are correctly installed, square to the BACK and well bedded down. Do not remove surplus glue, except that which would interfere with the fitting of the FRONT.

22 Leave this cabinet to dry and repeat 12 to 21 for the second cabinet.

23 Prepare for each cabinet six lumps of TERYLENE WOOL of one quarter of an ounce each. This is quite critical. The best method of measuring is to weigh up the total amount, 3 oz., then dividing it into two equal size $\frac{1}{2}$ oz. pieces, dividing these into two pieces each, ($\frac{1}{4}$ oz.) then each of these into three equal amounts of $\frac{1}{6}$ oz. each. So long as this is done carefully, the slight variation in final amounts will be negligible.

24 Apply dabs of glue at about 4 in. intervals along each of the three walls of the pipe. Tease out and insert one piece of TERYLENE WOOL in each section of the

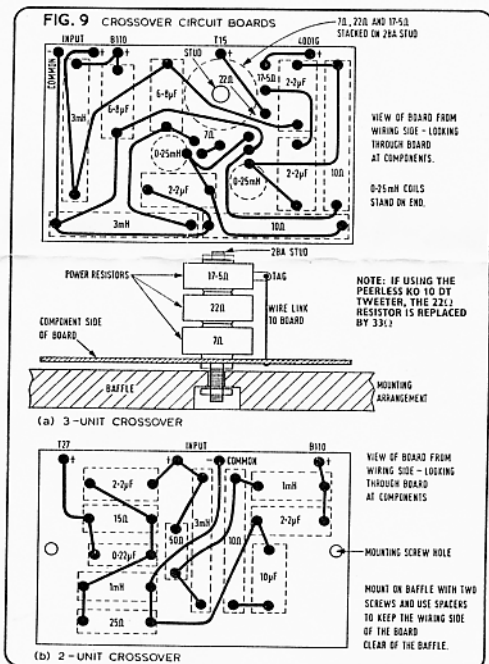

pipe. The piece in the fourth section follows the pipe around the corner to the short section which forms the aperture. There should now be a continuous length of terylene wool all along the pipe, with no lumps or bald patches.

25 Return to the first cabinet. Roll out four 'worms' of SEALING STRIP of $\frac{1}{2}$ in. diameter approximately, and lay them with no gaps along all the top edges of the SECTIONS to form a gasket between the SECTIONS and the FRONT.

26 Generally apply glue to all four edges of the FRONT but not around the aperture cut-out. Lay the FRONT onto the SECTIONS with the aperture towards the right and displaced to the left of the cabinet, see fig. 1. With a block of wood interposed for protection, hammer down the FRONT until it is flush with the front edges of the SIDES. Insert pins through the SIDES into the edges of the FRONT.

27 Repeat 25 and 26 for the second cabinet.

28 Return to first cabinet. Mount the terminal panel or socket on the BACK and, after connecting the wires, plug up any gaps to the 'outside' with Sealing Strip.

29 Insert into the cavity one piece of SPONGE SHEET to lie against the BACK and over the BRACE. It has not been found necessary to glue in the sponge, but this can be done by applying only a little glue to each corner. Bring the wire from the socket out around the edge of the sponge.

30 Roll up one piece of BONDED ACETATE FIBRE (BAF) of 24×12 in. into a solid cylinder 12 in. long and about 5 in. diameter. After having established which cabinet will have the bass unit displaced to which side, lay the BAF along a cavity diagonal so that it will clear the B110 magnet.

31 After cutting up sufficient lengths of $\frac{1}{4}$ in. wide strips of BAF, line the sides of the cavity between the BATTENS and the BACK. DO NOT cover the entrance to the pipe.

32 Tease out two more lumps of TERYLENE WOOL and install one each side of the BAF roll.

33 Lay the unassembled BAFFLE on the BATTENS to ensure that it fits.

34 Repeat 28 to 33 for the second cabinet.

35 Mount the drive units on the BAFFLES in accordance with the manufacturers' instructions. For the Coles 4001G, make a gasket of Sealing Strip, and also carefully plug the hole in the back of the unit where the voice coil wires pass through. This must be done, otherwise the low frequency pressures generated in the cavity will pass down the hole and vibrate the tweeter dome which will cause the voice coil lead-out wires to break. This modification does no harm to the tweeter nor does it affect performance.

36 Mount the crossover boards on the BAFFLES and wire up the drive units. When making connections to the T27 or 4001G, solder the wires to the vacant end of the solder tags; do not solder over the voice coil lead-out wires.

37 It is wise to check at this stage that the electrical side is working correctly. So, before fitting the baffles to the cabinets,

connect the crossover board input to an amplifier with a music source, with the bass and volume controls set at minimum. Advance the volume control so that something can just be heard, then check that the right part of the range is emitted by each drive unit. The best way to execute a tweeter is to connect it to the bass output of the crossover.

38 Roll out some more $\frac{1}{2}$ in. 'worms' of Sealing Strip and lay them in a continuous loop around the BATTENS.

39 Connect the cabinet connector wire to crossover input pins, ensuring that 'positive' is connected to 'positive'.

40 Fit the baffle into the cavity, making sure that the cylinder of BAF is clear of the

B110 magnet. Gently press the baffle down to lightly compress the Sealing Strip. Do not screw the baffle down yet.

41 Connect the speakers to an amplifier. Apply a 20 Hz tone at high level or organ bass notes from a record and listen carefully to check that no whistling or chuffing noises are generated. Hold a piece of tissue paper at one point so that it covers the pipe aperture. Check that the paper flaps vigorously and that it moves much further than the B110 cone. If all is well, and after all, it should be, screw the baffle down.

The loudspeakers are now ready for final embellishment to the choice of the constructor or his wife and for sitting back and listening to.

Materials & Components List

For two loudspeakers; all dimensions in inches.

4	$3\frac{1}{2} \times 6 \times \frac{1}{2}$	plywood or chipboard
4	$11 \times 6 \times \frac{1}{2}$	plywood or chipboard
2	$12 \times 11 \times \frac{1}{2}$	plywood or chipboard
2	$33\frac{1}{2} \times 11 \times \frac{1}{2}$	plywood or chipboard
2	$20 \times 11 \times \frac{1}{2}$	plywood or chipboard
2	$17\frac{1}{2} \times 5 \times \frac{1}{2}$	plywood or chipboard
2	$15 \times 5 \times \frac{1}{2}$	plywood or chipboard
2	$5\frac{1}{2} \times 5 \times \frac{1}{2}$	plywood or chipboard
2	$15\frac{1}{2} \times 5 \times \frac{1}{2}$	plywood or chipboard
2	$13 \times 11 \times \frac{1}{2}$	plywood only
6	$13 \times 1 \times 1$	deal
4	$x' \times 1 \times 1$	deal

Where 'x' = 11 in. minus twice the exact width of the wood used. This simple calculation is necessary as the planned size of 1 in. timber can vary from $\frac{1}{8}$ to $\frac{1}{4}$ in. and it is essential to have no gaps between the battens when they are fitted in the cavity of the cabinet.

$\frac{1}{2}$ pint Glue Evo Resin W or ICI Dufay

1 box 1 in. panel pins, bronze

1 packet Bostik Sealing Strip—do not use putty or any other setting compound

40 in. \times 24 in. Bonded Acetate Fibre

3 ounces Terylene Wool

2 off $12 \times 11 \times 1$ Plac Foam Sheet—cellular upholstery type (not 'Dunlopillo')

20 off $\frac{1}{4}$ in. No. 6 countersunk steel screws

3 Unit Versions only

2	B110	} Falcon Electronics, 26 Station Road, Bexhill-on-Sea, Sussex
2	T15 or KO 10 DT	
2	4001G	} or Badger Sound Services, 10 Central Drive, Ansdell, Lytham, Lancs.
4	3 mH inductor	
4	0.25 mH inductor	} RS Components Stock No. 113-617
4	6.8 μ F capacitor, polyester	
4	2.2 μ F capacitor, polyester	} RS Components Stock No. 113-594
2	7.1 Ω , 0.7 A resistor	
4	10 Ω , 10 W resistor	} RS Components Stock No. 154-315
2	22 Ω , 0.7 A resistor (T15 only)	
2	33 Ω , 0.7 A resistor (KO 10 DT only)	} RS Components Stock No. 10 W WW Res 10 ohms
2	17.5 Ω , 0.7 A resistor	
2	4 in. 2BA studding, nuts and washers	} RS Components Stock No. 154-422
6	$\frac{1}{2}$ in. round-head No. 4 screws—for mounting 4001G tweeters	

2 Unit Version only

2	B110	} Falcon or Badger, details as above
2	T27	
2	3 mH inductor	} RS Components Stock No. 113-623
4	1 mH inductor	
4	10 μ F capacitor, polyester	} RS Components Stock No. 113-594
4	2.2 μ F capacitor, polyester	
2	0.22 μ F capacitor, polyester	} RS Components Stock No. 113-055
2	10 Ω , 10 W resistor	
2	50 Ω , 5 W resistor	} RS Components Stock No. 10 W WW Res 10 Ω
2	15 Ω , 5 W resistor	
2	25 Ω , 5 W resistor	} RS Components Stock No. 5 W WW Res 50 Ω
2	15 Ω , 5 W resistor	

Common to both Versions

2	Matrix Board	RS Components	Stock No. 433-602
2	Connectors for fitting in rear of cabinet		

Components from RS Components may be obtained through a radio or hi-fi shop or by mail order from Doran Electronics Ltd., PO Box T78, Wellington Road Industrial Estate, Wellington Bridge, Leeds LS12 2UF. Tel. 0532 34222. RS Components themselves do not supply to the public. Alternatively, resistors and capacitors can be obtained from either Badger or Falcon, who will supply suitable substitutes for those specified. The crossover boards layouts may have to be altered, though. Complete assembled crossover boards are also supplied by Falcon and Badger. Although the construction is different from the drawings, the same circuits and recommended alternative components are used.

The price of the Coles 4001G tweeter at the time of writing is £5.63 + VAT. This figure may be confirmed by telephoning Mr. W. Ellison of Coles Engineering on 09924 66685.