

CP21/F

HIGH FREQUENCY COMPRESSION DRIVER

-Pro-



This compression tweeter is designed for use in multi-element loudspeaker systems in both sound reinforcement and studio applications. It features smooth response with wide controlled dispersion in the horizontal plane (140°). The voice coil is wound from flat aluminium wire, bonded to an aluminium diaphragm for extended response and excellent transient attack. The diaphragm assembly is field replaceable without soldering.

Modelo similar al CP22, pero con una dispersión horizontal muy amplia. Especialmente recomendado para aplicaciones que precisen de una gran definición en alta frecuencia, pero que además requieran una cobertura horizontal importante.

SPECIFICATIONS

Rated impedance	8 ohms.
Minimum impedance	8 ohms @ 9 kHz
D.C. Resistance	6.1 ohm
Power capacity*	25 w RMS
Program Power	50 Watts.
Sensitivity**	105 dB 1w @ 1m.
Frequency range	3.5 - 20 kHz
Recommended crossover	5 kHz or higher
Dispersion H x V	140° x 40°
Voice coil diameter	37.6 mm. 1.5 in.
Magnetic assembly weight	1.2 kg. 2.64 lb.
Flux density	1.55 T
BL Factor	5.2 N/A

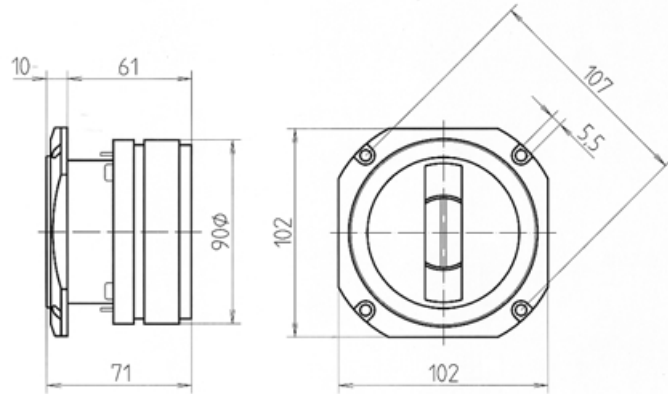

HORIZONTAL POLAR PATTERN

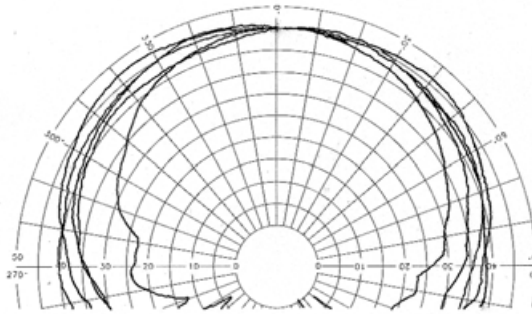

MOUNTING INFORMATION

Overall diameter	102 x 102 mm. 4 x 4 in.
Depth	72 mm. 2.83 in.
Baffle cutout dimensions	ø 92 mm. 3.62 in.
Bolt circle diameter	107 mm. 4.21 in.
Net weight	1.7 kg. 3.75 lb.
Shipping weight	1.75 kg. 3.85 lb.

MATERIALS

Diaphragm	Aluminium
Voice coil	Edgewound alum. ribbon
Voice coil former	Kapton
Magnet	Ferrite

FREQUENCY RESPONSE & DISTORTION CURVES, MAGN. On axis, 1w @ 1m.

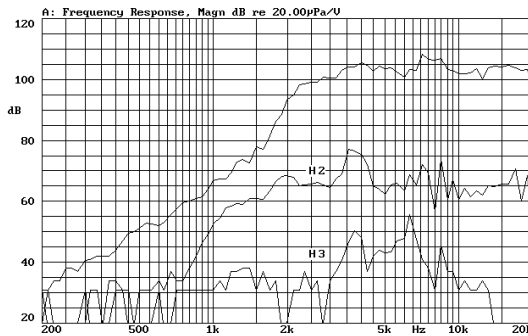

TIME RESPONSE, MAGN.

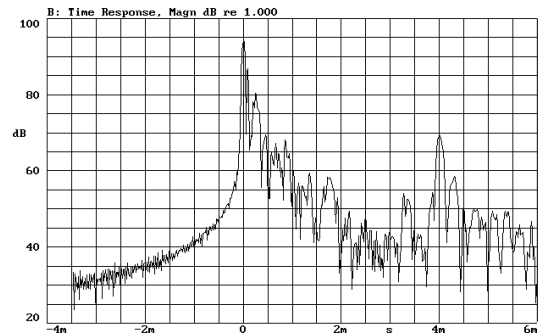

FREQUENCY RESPONSE PHASE. On axis, 1w @ 1m.

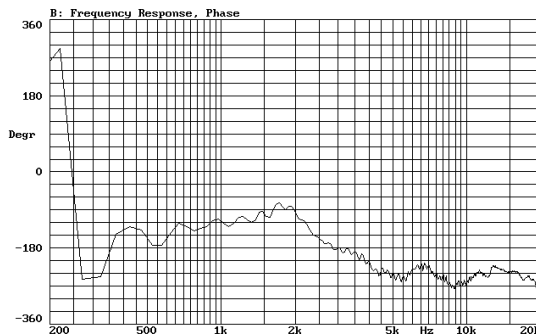

FREE AIR IMPEDANCE CURVE

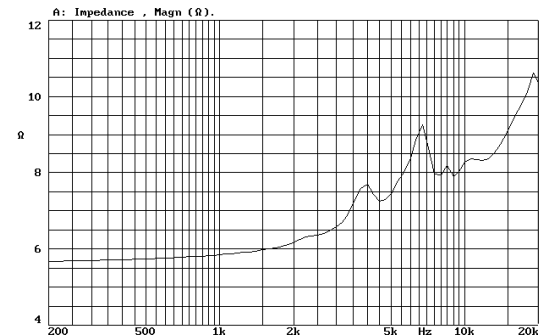

NOTES

*The power capacity corresponds to the RMS maximum value that can dissipate the loudspeaker when a sinus signal is applied for a period of at least two hours.
Program power is defined as the transducer's ability to handle normal music program material.
**Sensitivity was measured at 1m distance, on axis, with 1w input, averaged in the range 3-15 kHz.

NOTAS

* La potencia admisible corresponde a la máxima potencia RMS que puede disipar el altavoz durante al menos dos horas, cuando se le aplica una señal determinada. Por potencia programa se entiende la capacidad de altavoz en el manejo de señales transitorias como sería el proporcionado por el contenido de un pasaje musical normal.
**Medición realizada con el micrófono a 1 m de distancia, en el eje, aplicando 1w al altavoz, promediando en el rango 1-7 kHz.