

MECHANICAL DATA
Dimensions in mm

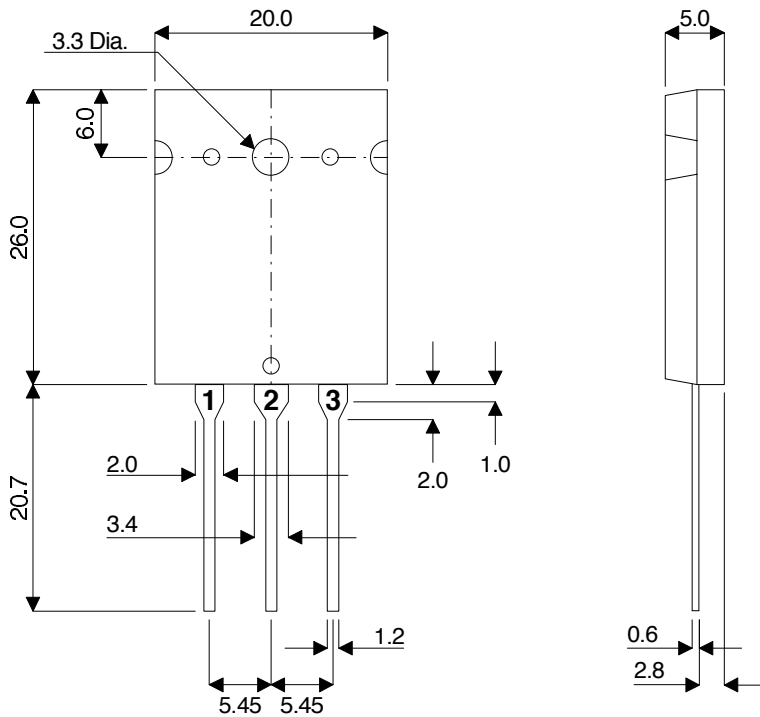

TO-3PBL

Pin 1 – Gate

Pin 2 – Source
Case is Source

Pin 3 – Drain

N-CHANNEL
POWER MOSFET

POWER MOSFETS FOR
AUDIO APPLICATIONS

FEATURES

- HIGH SPEED SWITCHING
- N-CHANNEL POWER MOSFET
- SEMEFAB DESIGNED AND DIFFUSED
- HIGH VOLTAGE (160V & 200V)
- HIGH ENERGY RATING
- ENHANCEMENT MODE
- INTEGRAL PROTECTION DIODE
- P-CHANNEL ALSO AVAILABLE AS BUZ905DP & BUZ906DP
- DOUBLE DIE PACKAGE FOR MAXIMUM POWER AND HEATSINK SPACE

ABSOLUTE MAXIMUM RATINGS

($T_{case} = 25^{\circ}C$ unless otherwise stated)

		BUZ900DP	BUZ901DP
V_{DSX}	Drain – Source Voltage	160V	200V
V_{GSS}	Gate – Source Voltage	$\pm 14V$	
I_D	Continuous Drain Current	16A	
$I_{D(PK)}$	Body Drain Diode	16A	
P_D	Total Power Dissipation @ $T_{case} = 25^{\circ}C$	250W	
T_{stg}	Storage Temperature Range	-55 to $150^{\circ}C$	
T_j	Maximum Operating Junction Temperature	$150^{\circ}C$	
$R_{\theta JC}$	Thermal Resistance Junction – Case	$0.5^{\circ}C/W$	

STATIC CHARACTERISTICS ($T_{case} = 25^{\circ}C$ unless otherwise stated)

Characteristic		Test Conditions		Min.	Typ.	Max.	Unit
BV _{DSX}	Drain – Source Breakdown Voltage	V _{GS} = -10V I _D = 10mA	BUZ900DP	160			V
			BUZ901DP	200			
BV _{GSS}	Gate – Source Breakdown Voltage	V _{DS} = 0	I _G = ±100µA	±14			V
V _{GS(OFF)}	Gate – Source Cut-Off Voltage	V _{DS} = 10V	I _D = 100mA	0.1		1.5	V
V _{DS(SAT)*}	Drain – Source Saturation Voltage	V _{GD} = 0	I _D = 16A			12	V
I _{DSX}	Drain – Source Cut-Off Current	V _{GS} = -10V	V _{DS} = 160V BUZ900DP			10	mA
			V _{DS} = 200V BUZ901DP			10	
yfs*	Forward Transfer Admittance	V _{DS} = 10V	I _D = 3A	1.4		4	S

DYNAMIC CHARACTERISTICS ($T_{case} = 25^{\circ}C$ unless otherwise stated)

Characteristic		Test Conditions		Min.	Typ.	Max.	Unit
C _{iss}	Input Capacitance	V _{DS} = 10V f = 1MHz			950		pF
C _{oss}	Output Capacitance				550		
C _{rss}	Reverse Transfer Capacitance				18		
t _{on}	Turn-on Time	V _{DS} = 20V I _D = 7A			160		ns
t _{off}	Turn-off Time				80		

* Pulse Test: Pulse Width = 300µs , Duty Cycle ≤ 2%.

